

HIQ designing

Presented electric wiring plans were made with the help of [Elwin](#) software which is made by [3xM Automation company](#). New plans can be made with modification of included [Elwin project](#) or with modification of [DXF plans](#) with any DXF capable program. With the Elwin project, all HIQ symbols are included. The whole design plan can be also downloaded as a [PDF file](#).

Page 1- Power distribution-RCD switch and power meter

Single phase power input, connection of RCD switch (Residual Current Device) and [power meter](#). Input can be single or three phase.

The [power meter](#) on the wiring plan is connected to measure the whole electricity consumption, but can be connected to any device (or group of devices). Only single phase electricity measurement is available.

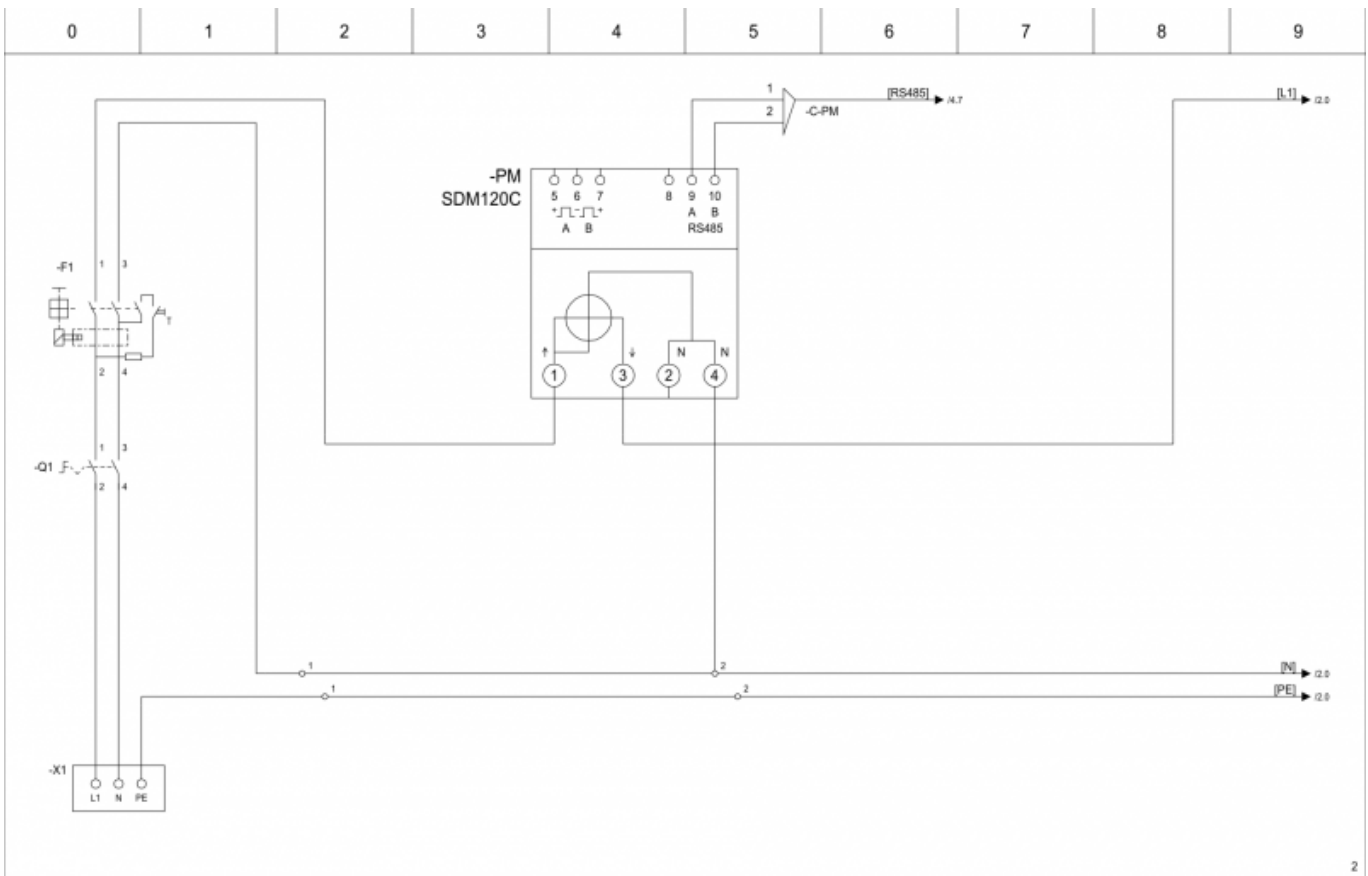

				Last changed by SS		 Robotina d.o.o. OIC Kozina 38 SI-6240 Kozina	POWER DISTRIBUTION		Drawing number 001		Installation =		
				Last changed 8/11/2016			HIQ wiring diagrams		Pages 38		Location +		
Rev				Revision text			Signature		Date		9/11/2016		Page number 1

Page 2-3 - Power distribution - Fuses

Suggested fuse plan.

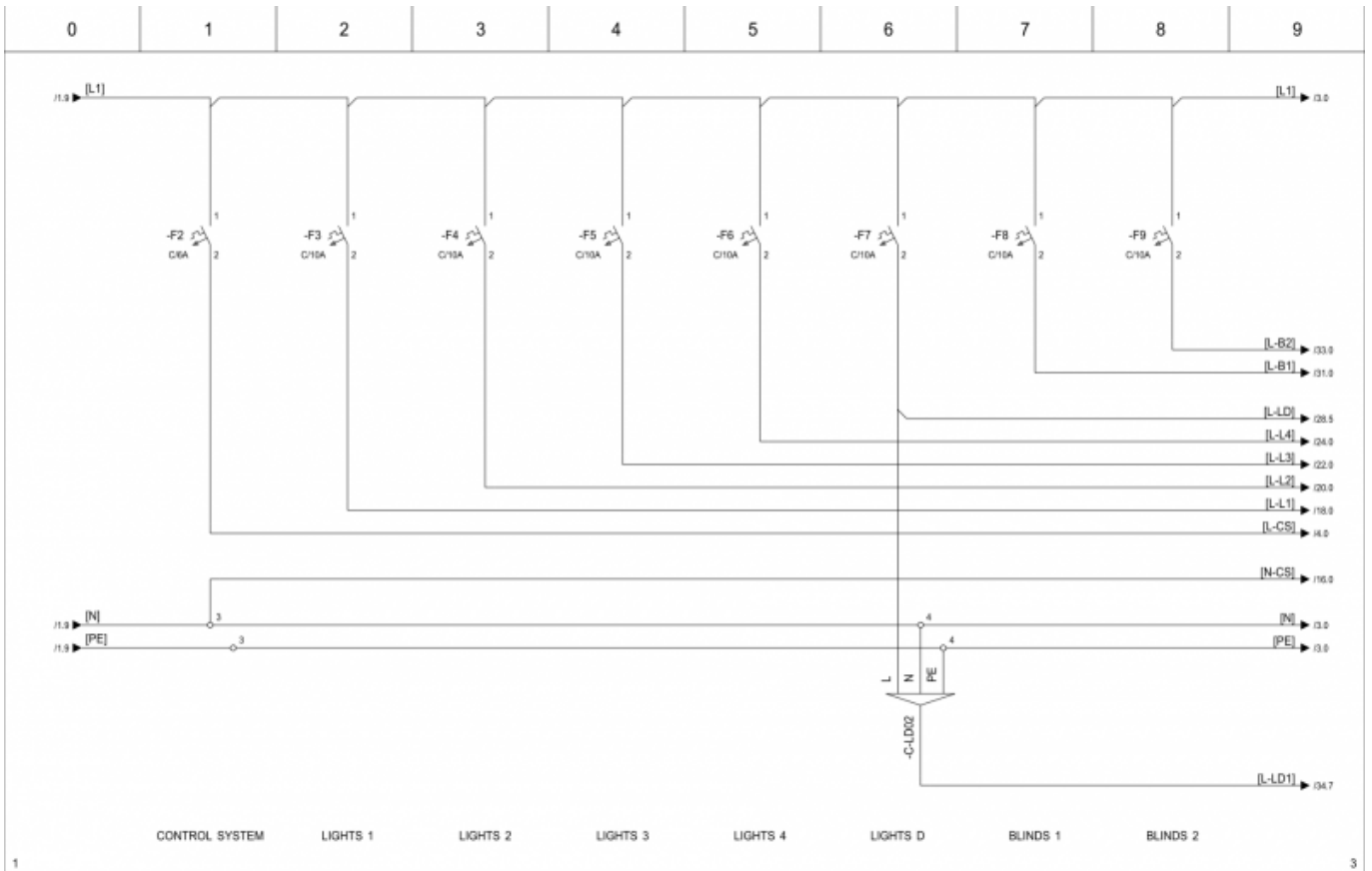

			Last changed by SS Last changed 7/11/2016 Print date 9/11/2016		Robotina d.o.o. OIC Kozina 38 SI-6240 Kozina	POWER DISTRIBUTION HIQ wiring diagrams		Drawing number 001		Installation =	
Rev			Signature					Pages 38		Location + Page number 2	

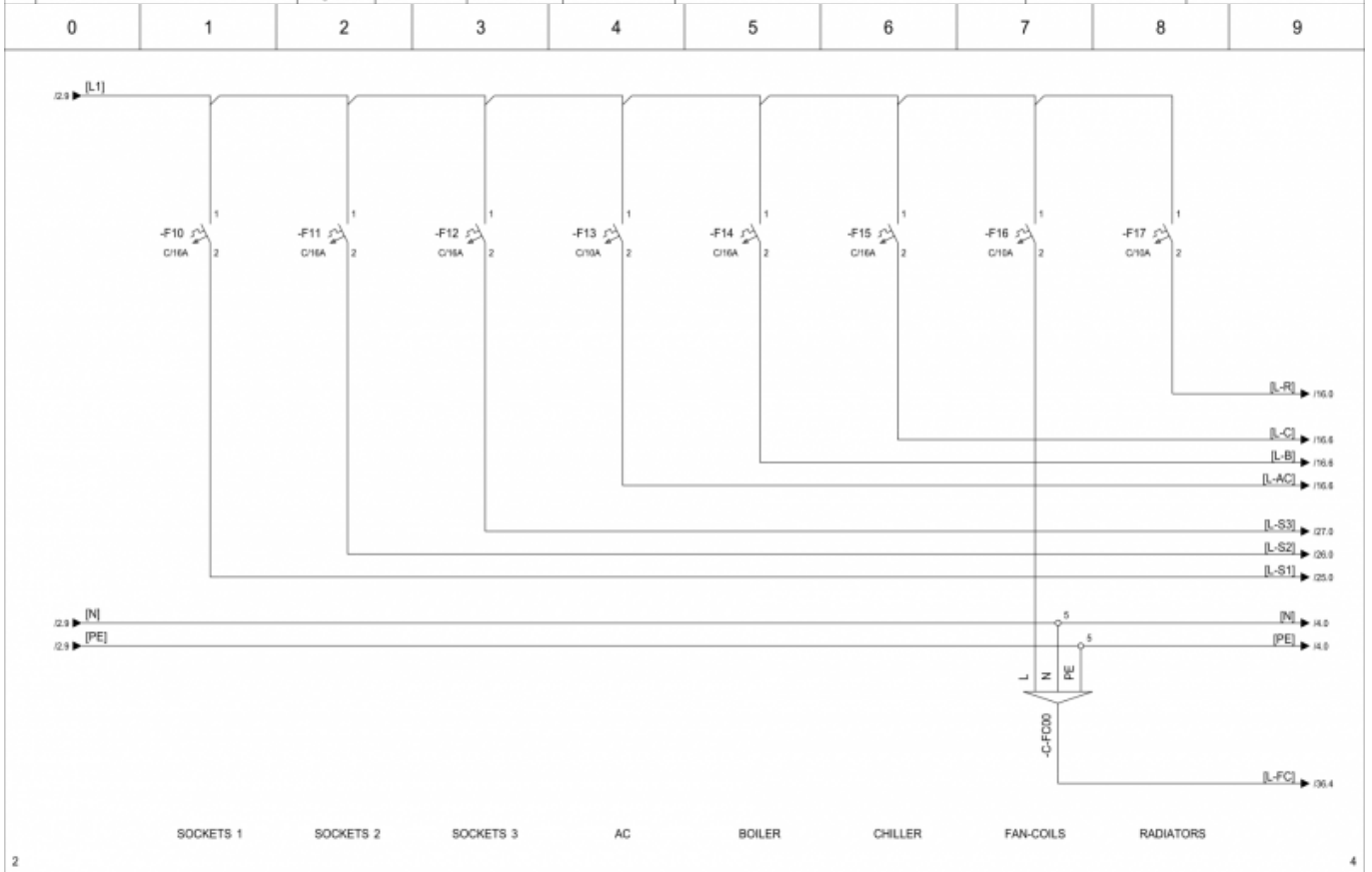

			Last changed by GK Last changed 2/11/2016 Print date 9/11/2016		Robotina d.o.o. OIC Kozina 38 SI-6240 Kozina	POWER DISTRIBUTION HIQ wiring diagrams		Drawing number 001		Installation =	
Rev			Signature					Pages 38		Location + Page number 3	

Page 4 - Control System-Power supply, HC, CAD-232

24V power supply (PS) for control system, Home controller and CAD-232-A2-IQ.

24V power supply can be optionally used for LED lighting (up to 2.5A with serial power supply, larger power supply can be used).

Home controller (HC) is the heart of the system. It is connected to the network (ETH) and has optional inputs (connections are on page 15) and outputs (connections are on page 16).

CAD-232-A2-IQ expander is used as communication interface between home controller and power meter (If power meter is not used then the expander is not necessary). It is connected to a home controller through IEX bus, to COM2 on home controller input and to power meter (RS485 communication).

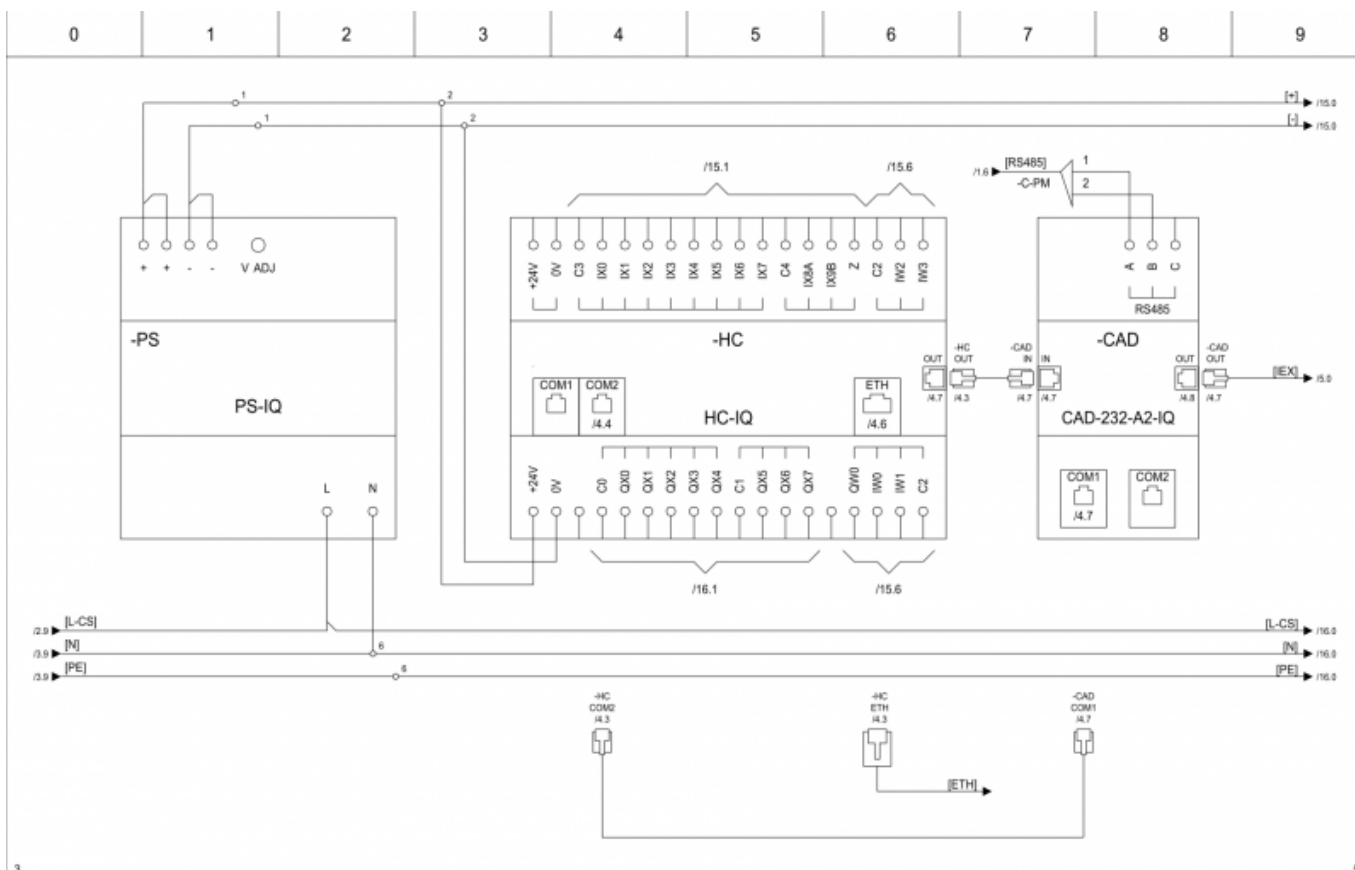

3				Last changed to SS Last changed 9/11/2016 Drawn 9/11/2016	 Robotina d.o.o. OIC Kozina 38 SI-6240 Kozina	CONTROL SYSTEM HIQ wiring diagrams	Drawing number 001 Pages 38	Installation = Location + Page number 4
Rev	Revision text	Signature	Date					

Page 5-6 - CS-Light controller 00 and 01

Light controllers (LC) are connected to IEX bus, we can connect up to up 4 LC to 1 home controller. On the top side are inputs and on the bottom side are outputs (connections are on page 17-24).

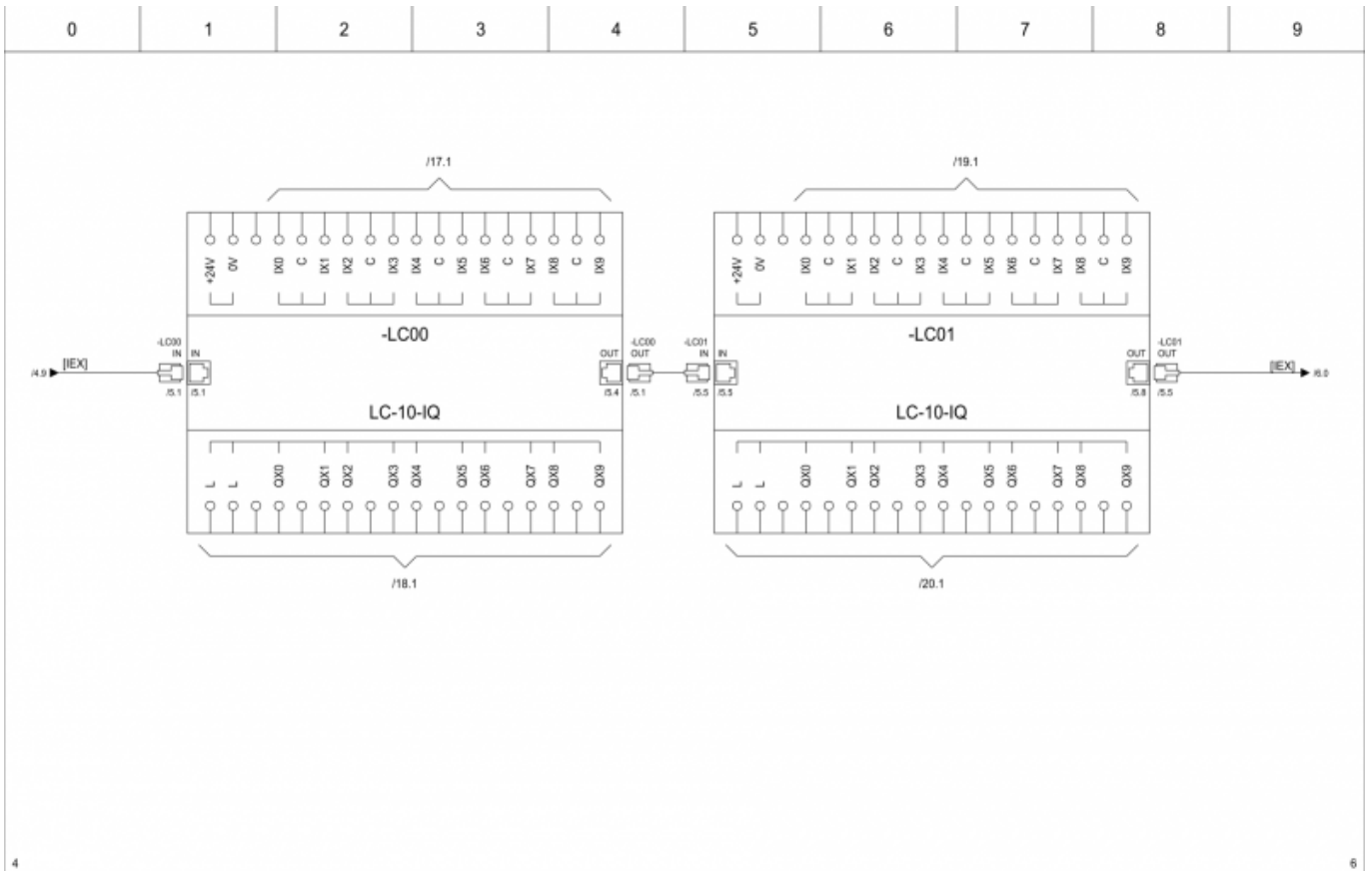

			Last changed by GK Last changed 20/10/2016 Print date 9/11/2016		Robotina d.o.o. OIC Kozina 38 SI-6240 Kozina	CONTROL SYSTEM HIQ wiring diagrams		Drawing number 001 Pages 38		Installation = Location + Page number 5	
Rev	Revision text	Signature	Date								

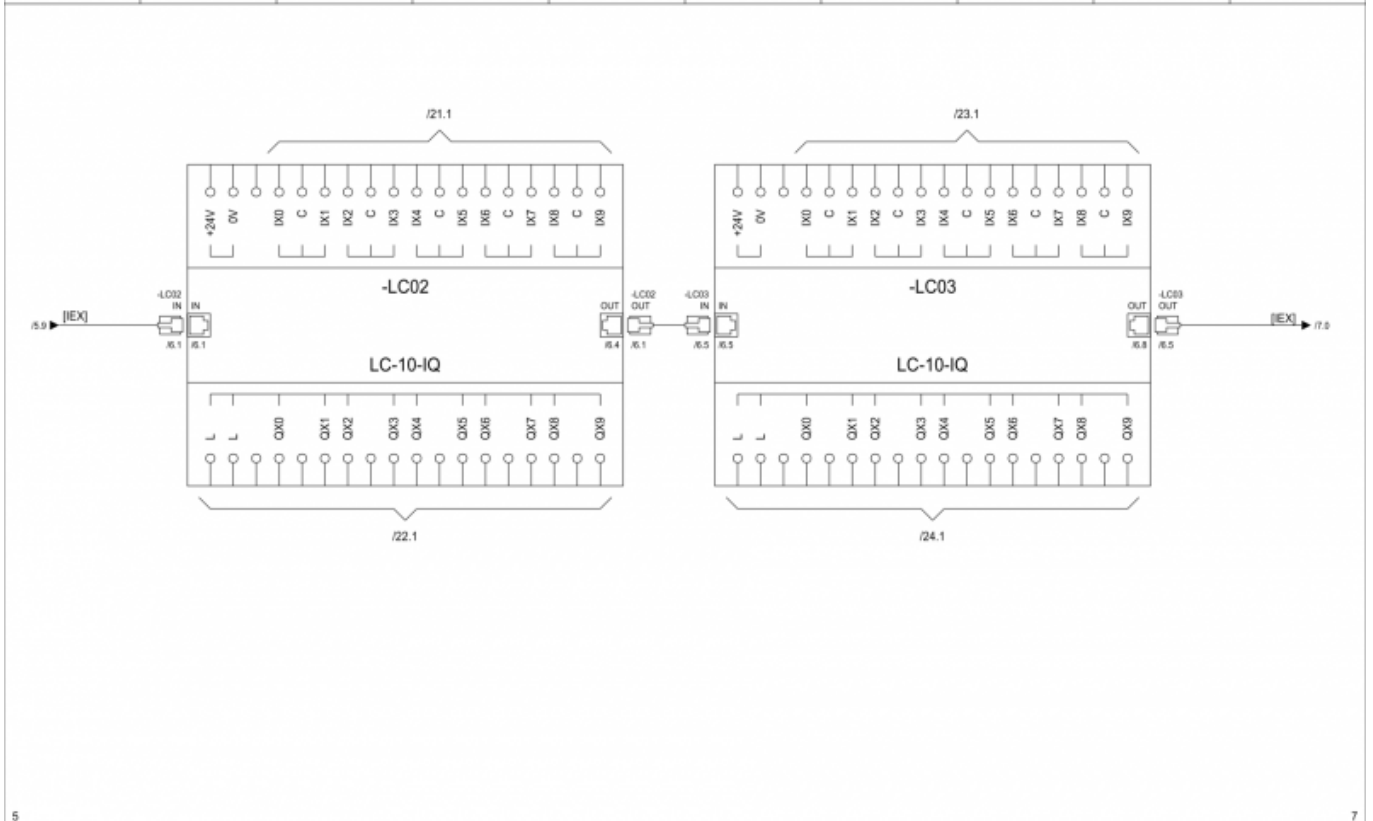

			Last changed by GK Last changed 20/10/2016 Print date 9/11/2016		Robotina d.o.o. OIC Kozina 38 SI-6240 Kozina	CONTROL SYSTEM HIQ wiring diagrams		Drawing number 001 Pages 38		Installation = Location + Page number 6	
Rev	Revision text	Signature	Date								

Page 7 - CS - Light dimmer

Up to 4 light dimmers can be connected to 1 HC. On sample plan we use 2 [Light dimmers drivers](#) for LUD-12 universal light dimmers.

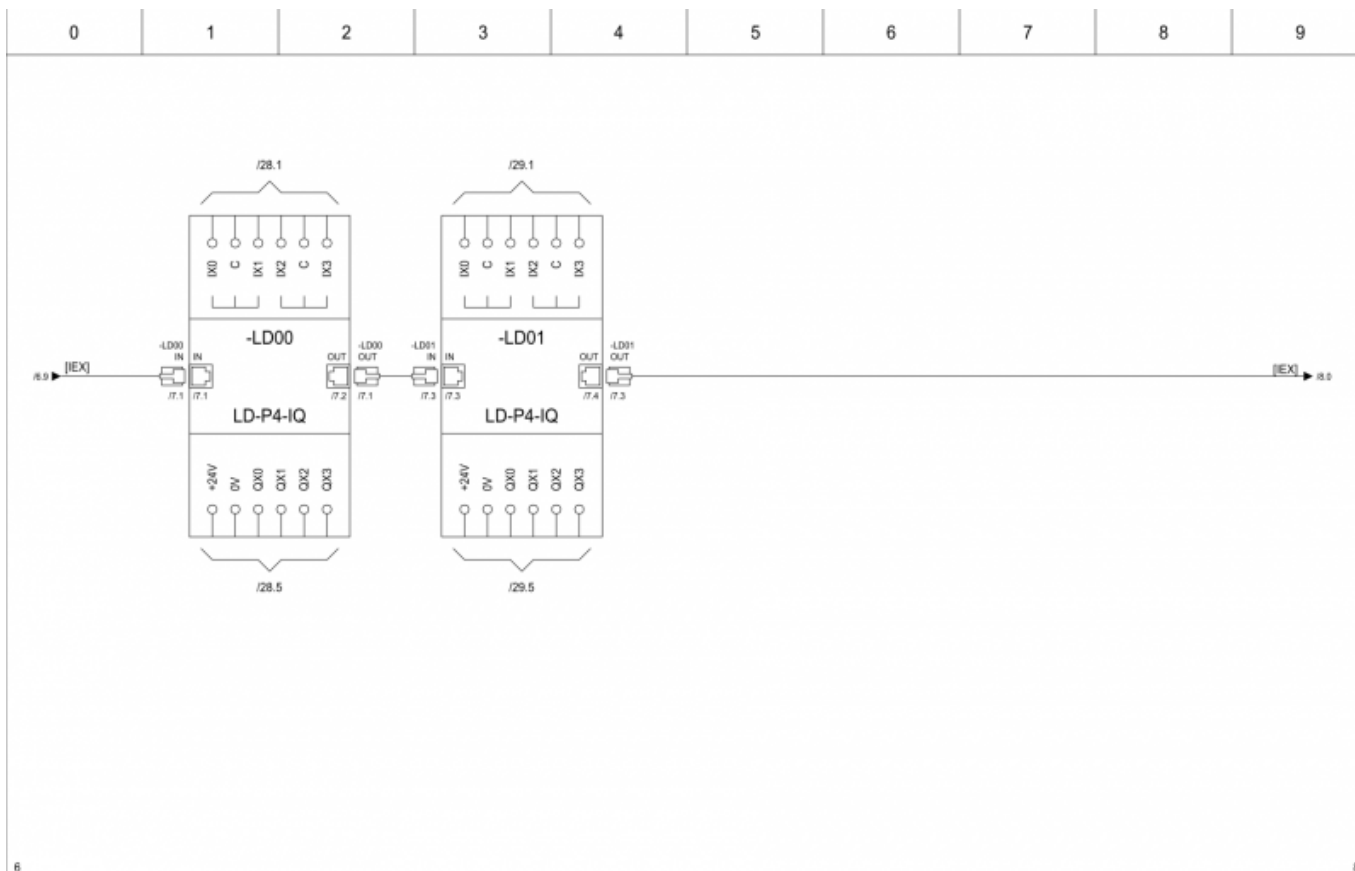

				Last changed by SS Last changed 9/11/2016 Drawn 9/11/2016	 Robotina d.o.o. OIC Kozina 38 SI-6240 Kozina	CONTROL SYSTEM	Drawing number 001	Installation = Location +
Rev	Revision text	Signature	Date	9/11/2016		HIQ wiring diagrams	Pages 38	Page number 7

Page 8 - CS - Blinds controllers

Up to 2 [Blinds controllers \(BC\)](#) can be connected to 1 HC.

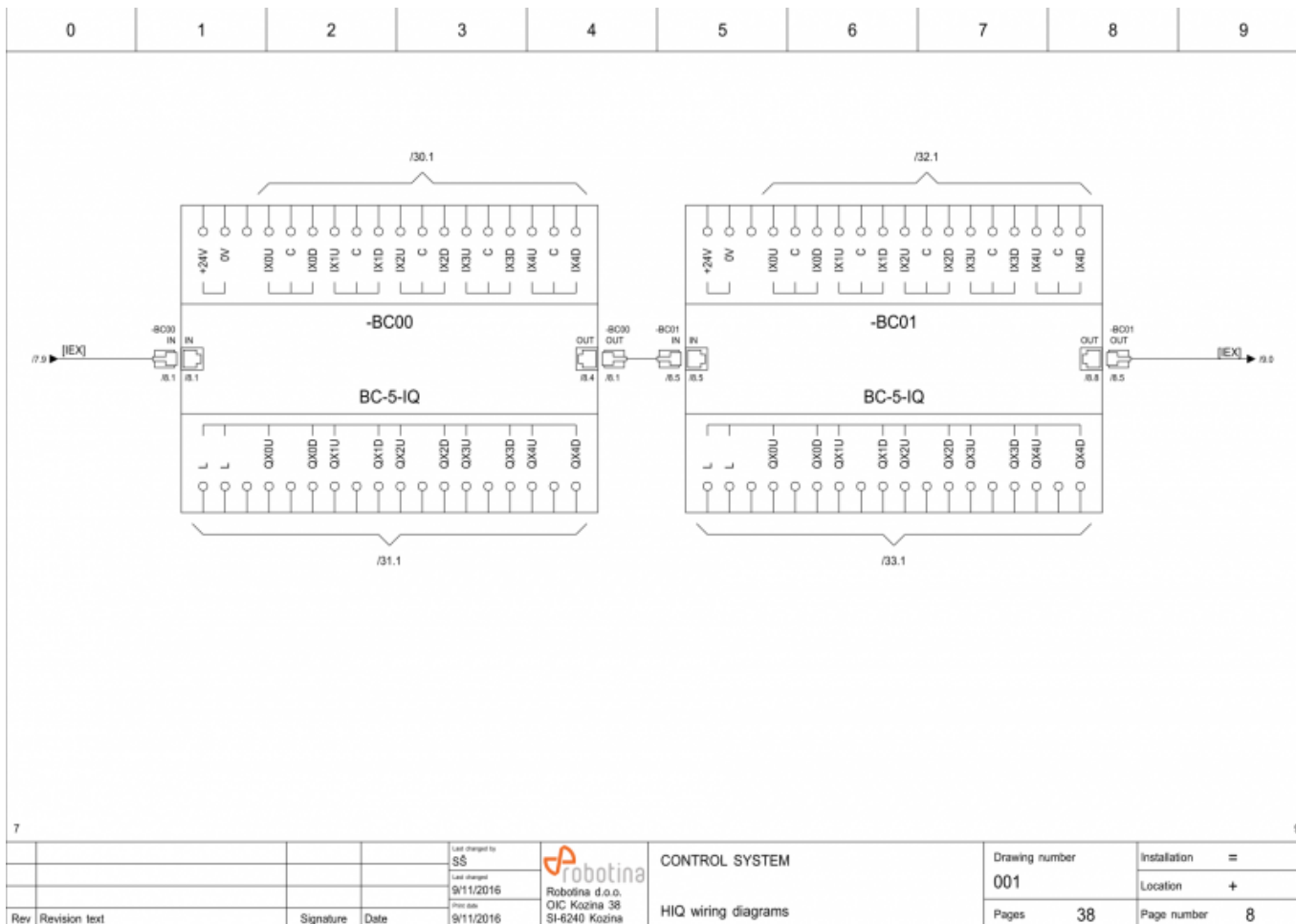

Page 9 - CS - bus extender, LED light dimmer

Bus extender (BE) is a passive switch for easy IEX bus interconnection between cabinet and field modules.

Up to 4 light dimmers can be connected to 1 HC. On sample plan we use 2 LED stripe dimmers.

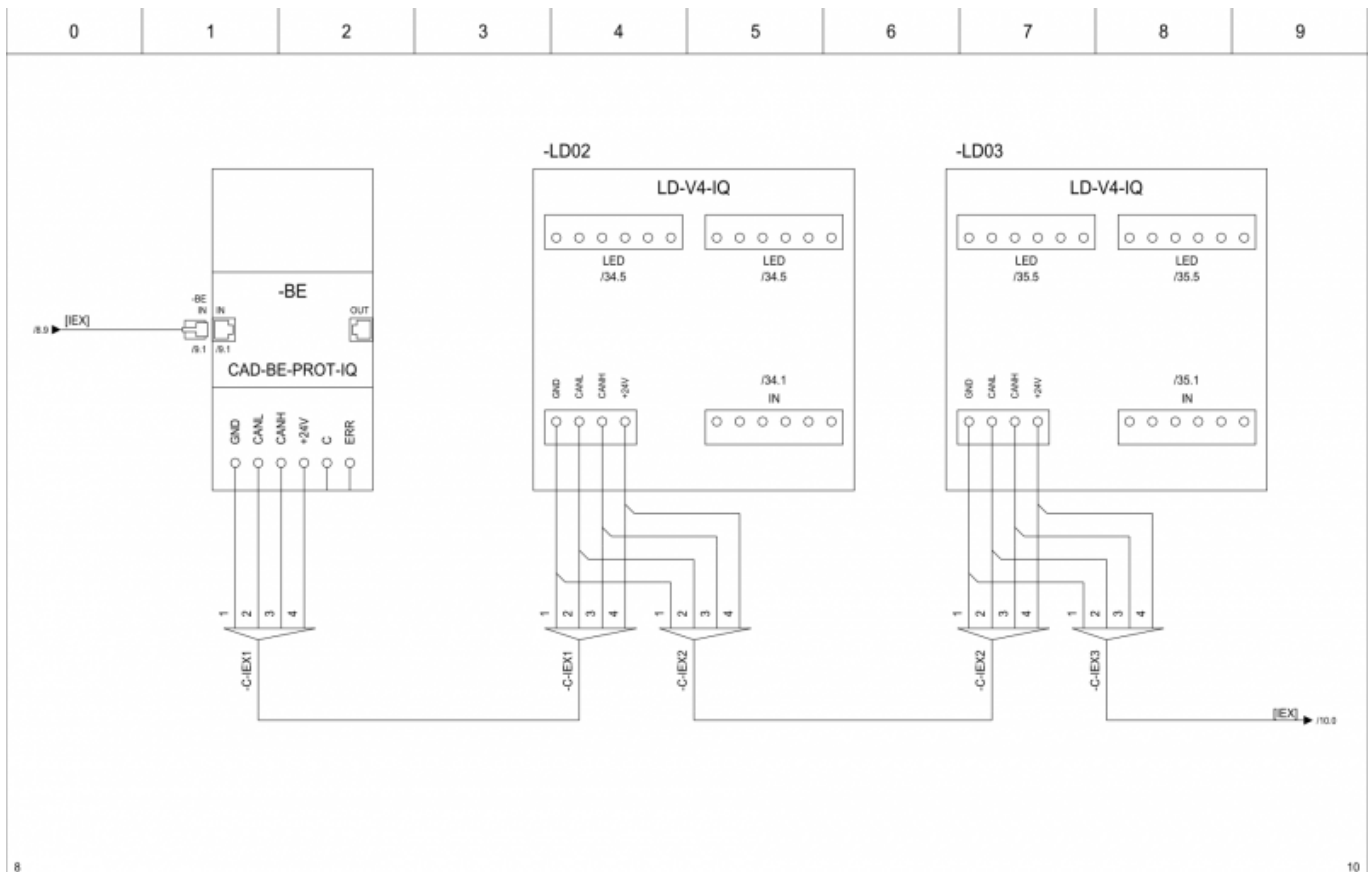

				Last changed by SS Last changed 9/11/2016 Drawn 9/11/2016		Robotina d.o.o. OIC Kozina 38 SI-6240 Kozina		CONTROL SYSTEM HIQ wiring diagrams		Drawing number 001 Pages 38		Installation = Location + Page number 9	
Rev	Revision text	Signature	Date										

Page 10 - CS - Scene controllers

Up to 4 Scene Controllers can be connected to 1 HC. On sample plan are 4 [Scene Touch Panels](#), but also [Scene Panels](#) and [Scene controllers](#) can be connected in the same way.

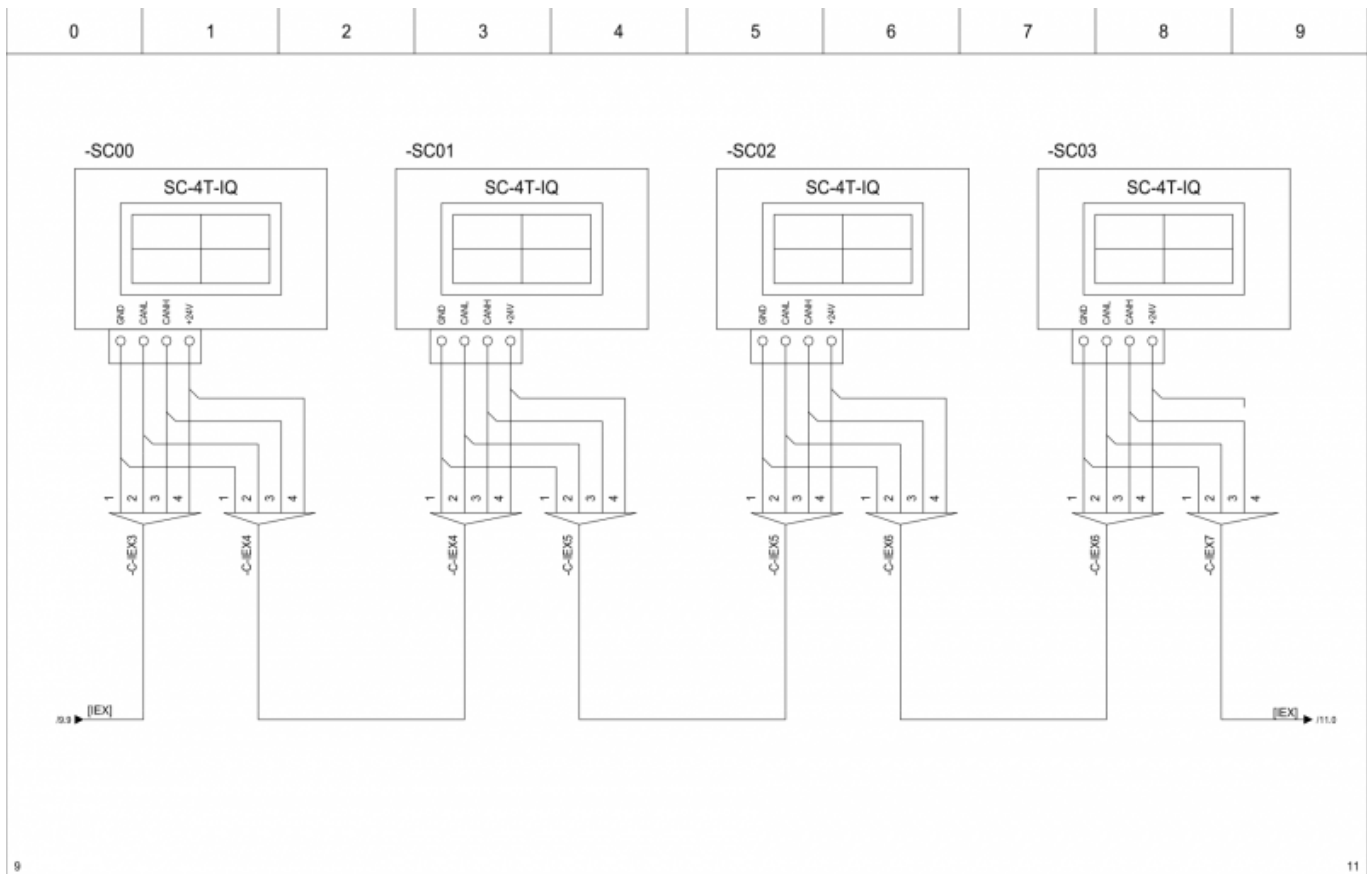

			Last changed by SS Last changed 8/11/2016 Print date 9/11/2016	 Robotina d.o.o. OIC Kozina 38 SI-6240 Kozina	CONTROL SYSTEM HIQ wiring diagrams	Drawing number 001 Pages 38	Installation = Location + Page number 10
Rev	Revision text	Signature	Date				

Page 11-12 - CS - Thermostats

Up to 5 Thermostats can be connected to 1 HC. On sample plan we use 5 [Touch buttons electronic thermostats](#), but also ordinary [Electronic thermostats](#) and [Blind electronic thermostats](#) can be connected in a similar way.

Optionally we can connect window switch on each thermostat (sample on -TH02 and -TH03) (not possible with [Blind electronic thermostat](#)).

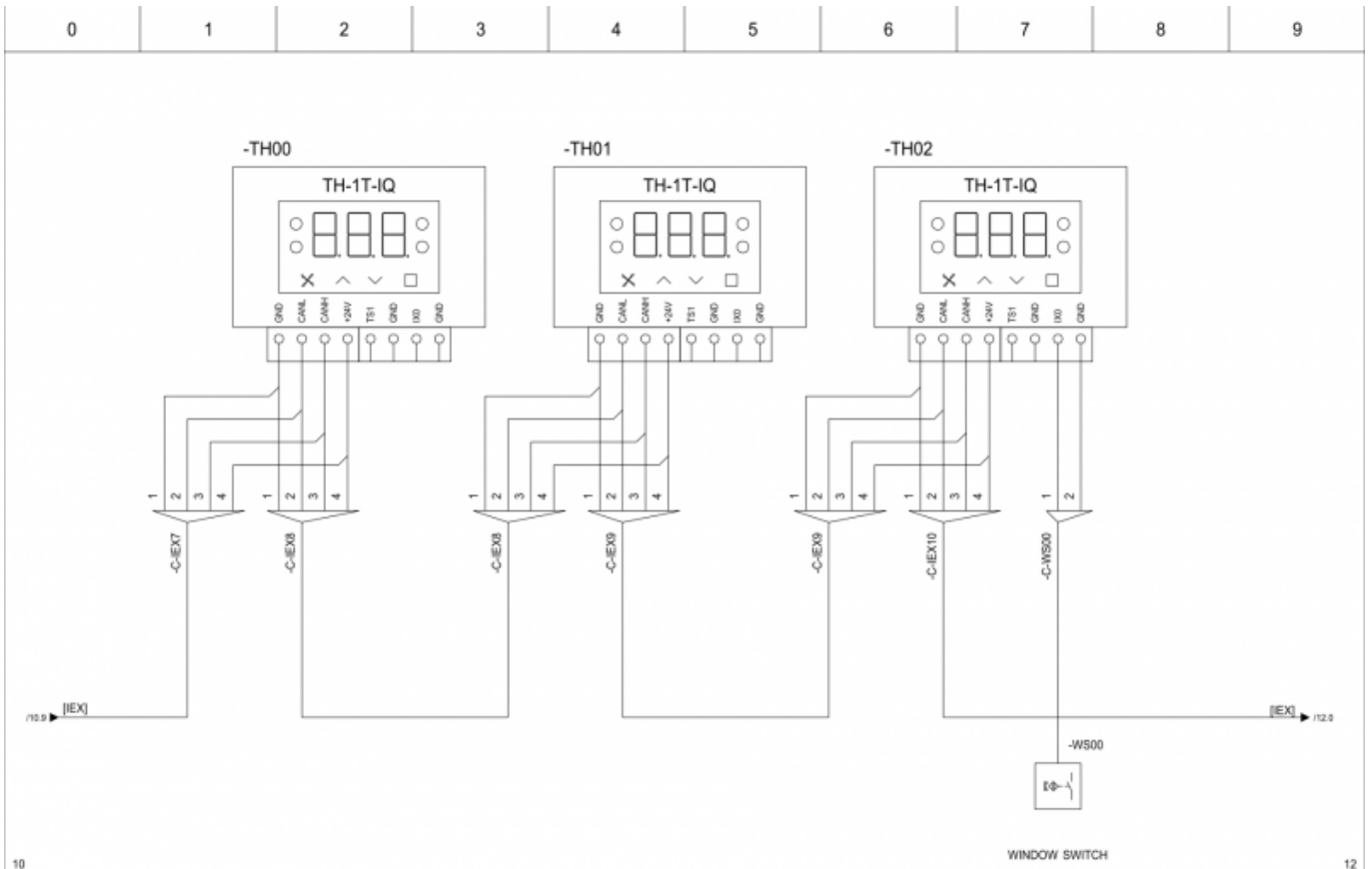

			Last changed by SS Last changed 8/11/2016 Drawn by 8/11/2016	Robotina d.o.o. OIC Kozina 38 SI-6240 Kozina	CONTROL SYSTEM	Drawing number 001	Installation = Location +
Rev	Revision text	Signature	Date		8/11/2016	HIQ wiring diagrams	Pages 38 Page number 11
0	1	2	3	4	5	6	7

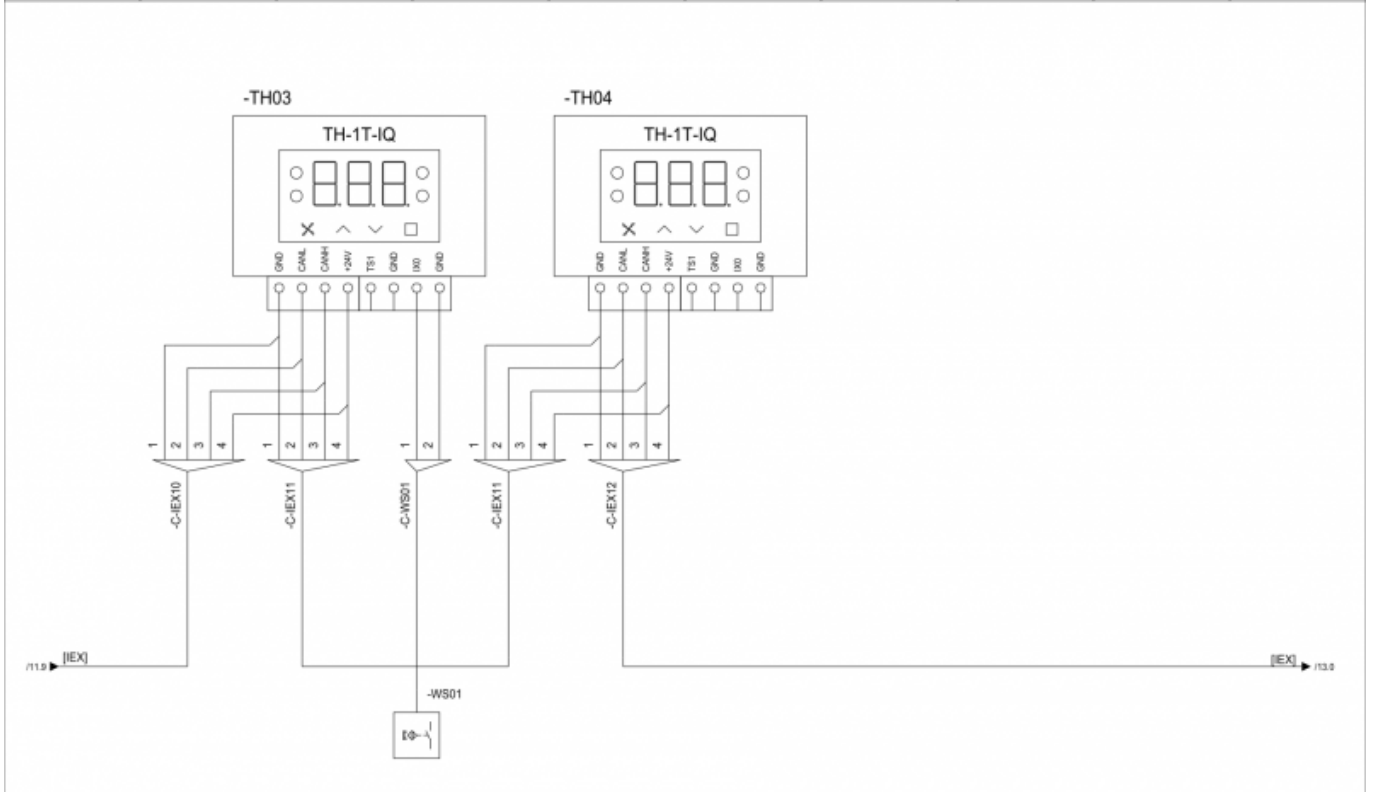

			Last changed by SS Last changed 8/11/2016 Drawn by 8/11/2016	Robotina d.o.o. OIC Kozina 38 SI-6240 Kozina	CONTROL SYSTEM	Drawing number 001	Installation = Location +
Rev	Revision text	Signature	Date		8/11/2016	HIQ wiring diagrams	Pages 38 Page number 12
0	1	2	3	4	5	6	7

Page 13 - CS-Fan-coil

Up to 5 Fan-coil controllers (FC) can be connected to 1 HC. On our sample plan we have 3 FC, 2 thermostats are controlling radiator valves (page 36-38).

FC controllers are the last items on IEX bus. Longer IEX bus lines (over 100m) must be terminated with a 120ohm resistor between CANL and CANH (-R1).

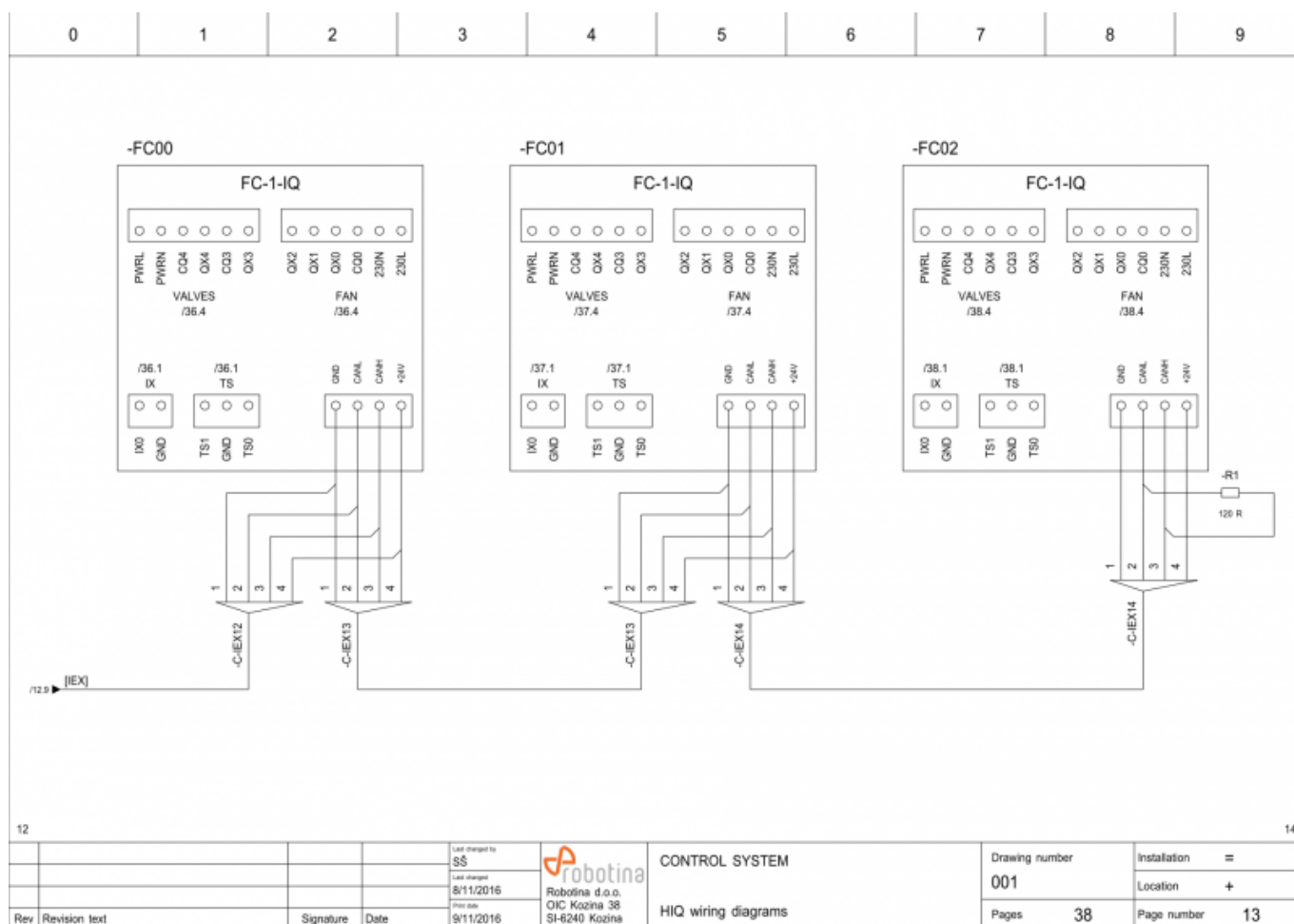

Page 14 - CS-Blank page

Blank page for future extensions.

0	1	2	3	4	5	6	7	8	9
---	---	---	---	---	---	---	---	---	---

SPARE PAGE -
INTENTIONALLY LEFT BLANK

13

15

				Last changed by GK Last changed 19/8/2016 Drawn by 9/11/2016	 Robotina d.o.o. OIC Kozina 38 SI-6240 Kozina	CONTROL SYSTEM HIQ wiring diagrams	Drawing number 001 Pages 38	Installation = Location + Page number 14
Rev	Revision text	Signature	Date					

Page 15 - Home controller inputs

If used, optional [lightness sensor](#) must be connected to IW0 analog input on [home controller](#).
 All other inputs are left for custom programming solutions (10 digital inputs IX0-IX7, IX8A, IX9B and 3 8-bit analog inputs IW1-IW3).

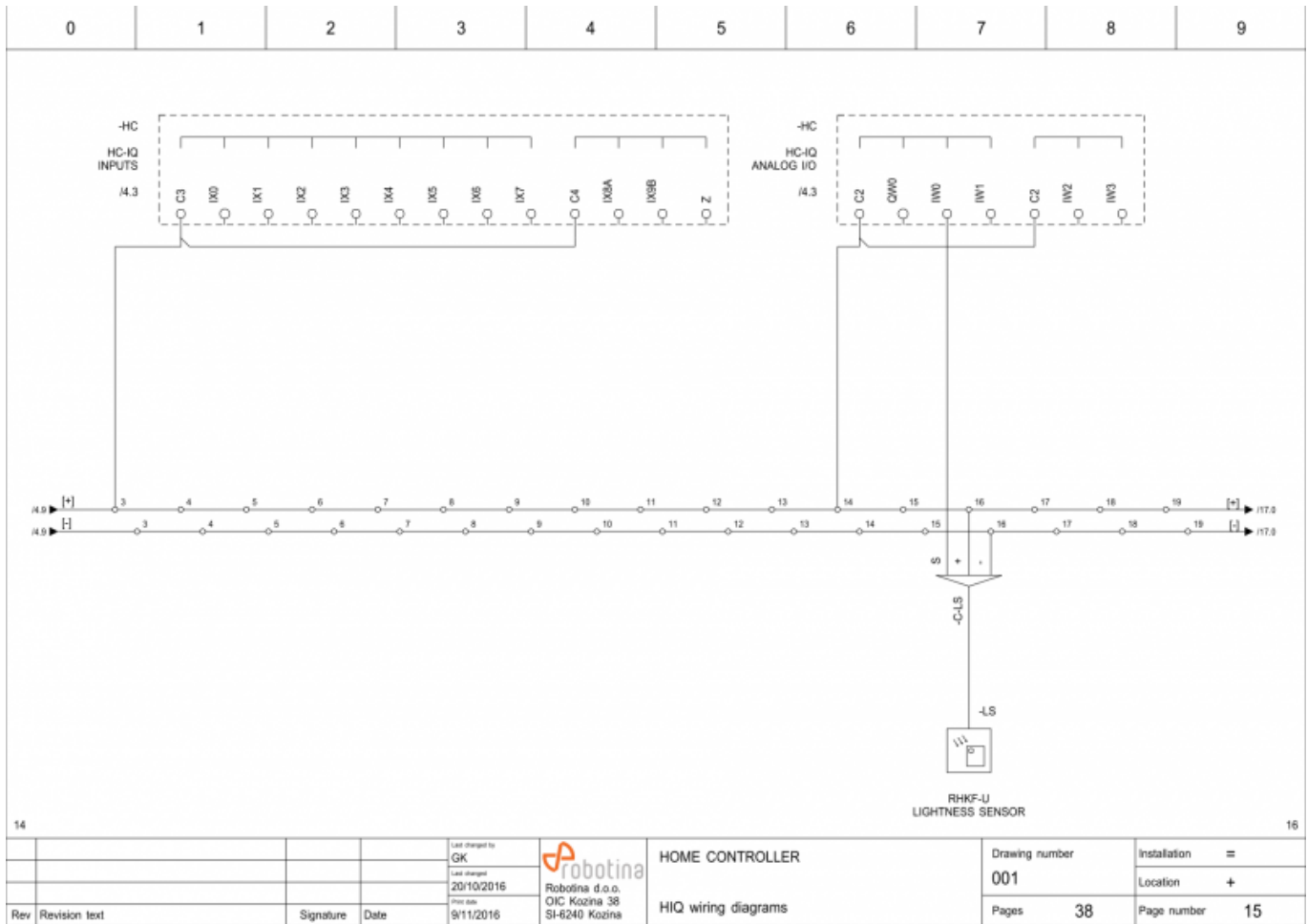

Page 16 - Home controller outputs

QX0-QX4 outputs - can be used for radiator valves or to control other heating/cooling devices. Internal relay is used for valves, other loads are recommended to use an additional 16A installation relay.

In our plan we use 2 radiator valves (and 3 [Fan-coil controllers](#)).

QX5 output - is used for Air Conditioner.

QX6 output - is used for Boiler.

QX7 output - is used for Chiller.

All three outputs are connected to external installation relays (-K.A, -K.B and -K.C) .

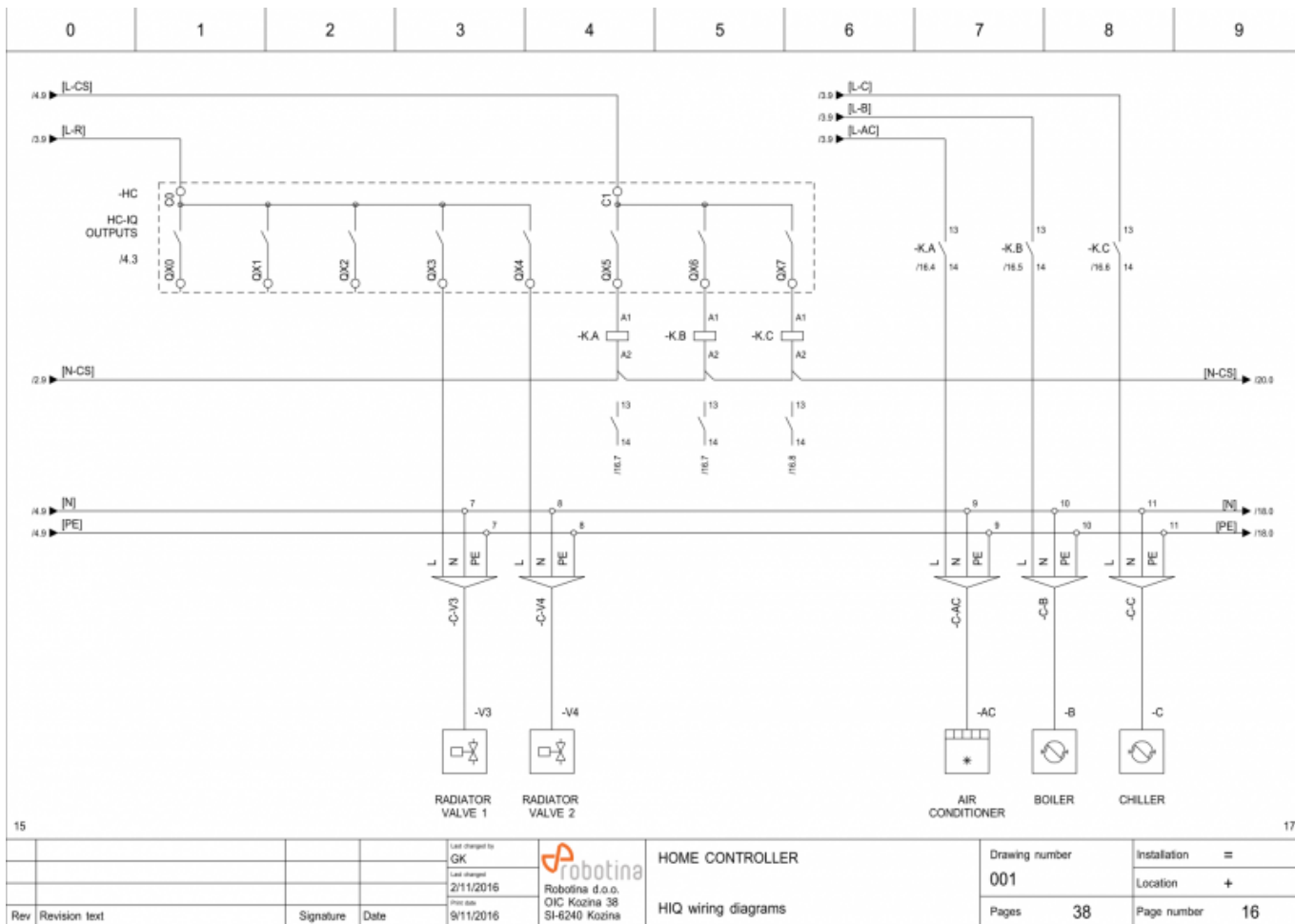

Page 17-24 - Light controller

Lights and managed power sockets are connected to [Light controllers](#) .

Several button combinations are possible.

Managed power sockets should be connected through installation relays (-K12-K14, -K22-K23 and -K30-K33).

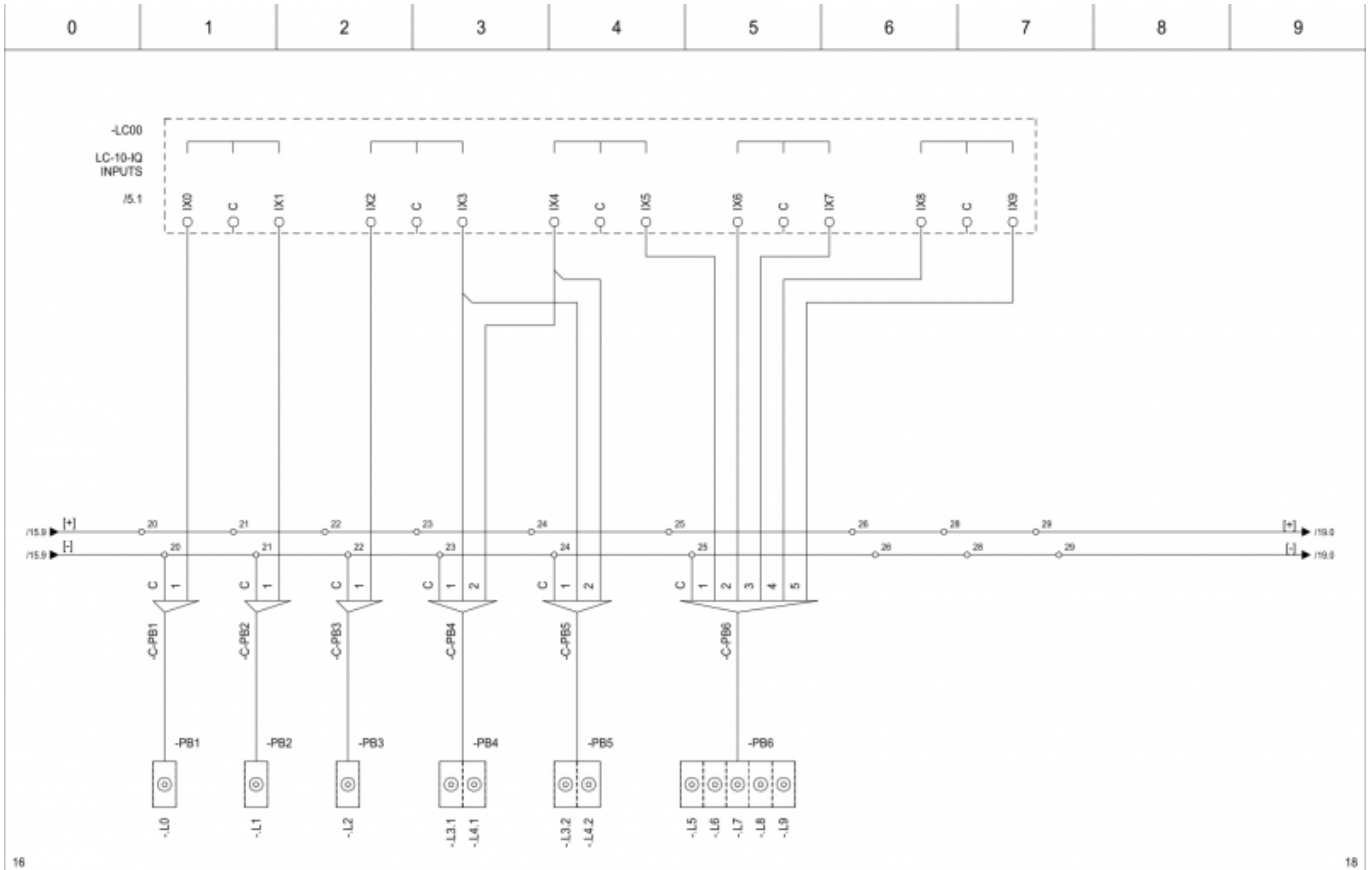

			Last changed by: GK Last changed: 20/10/2016 Print date: 9/11/2016		Robotina d.o.o. OIC Kozina 38 SI-6240 Kozina	LIGHT CONTROLLER HIQ wiring diagrams		Drawing number: 001 Pages: 38		Installation: = Location: + Page number: 17	
Rev	Revision text	Signature	Date								

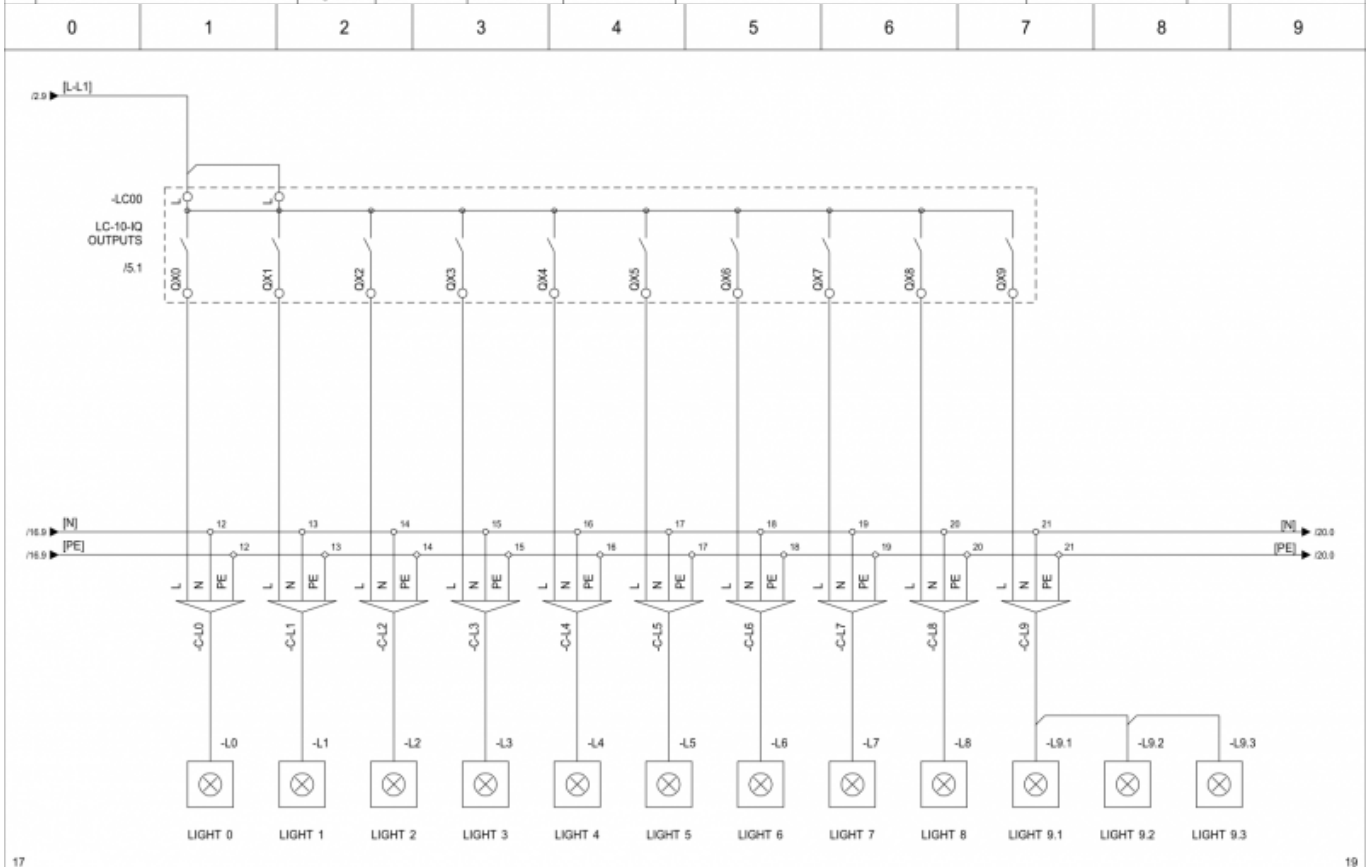

			Last changed by: SS Last changed: 8/11/2016 Print date: 9/11/2016		Robotina d.o.o. OIC Kozina 38 SI-6240 Kozina	LIGHT CONTROLLER HIQ wiring diagrams		Drawing number: 001 Pages: 38		Installation: = Location: + Page number: 18	
Rev	Revision text	Signature	Date								

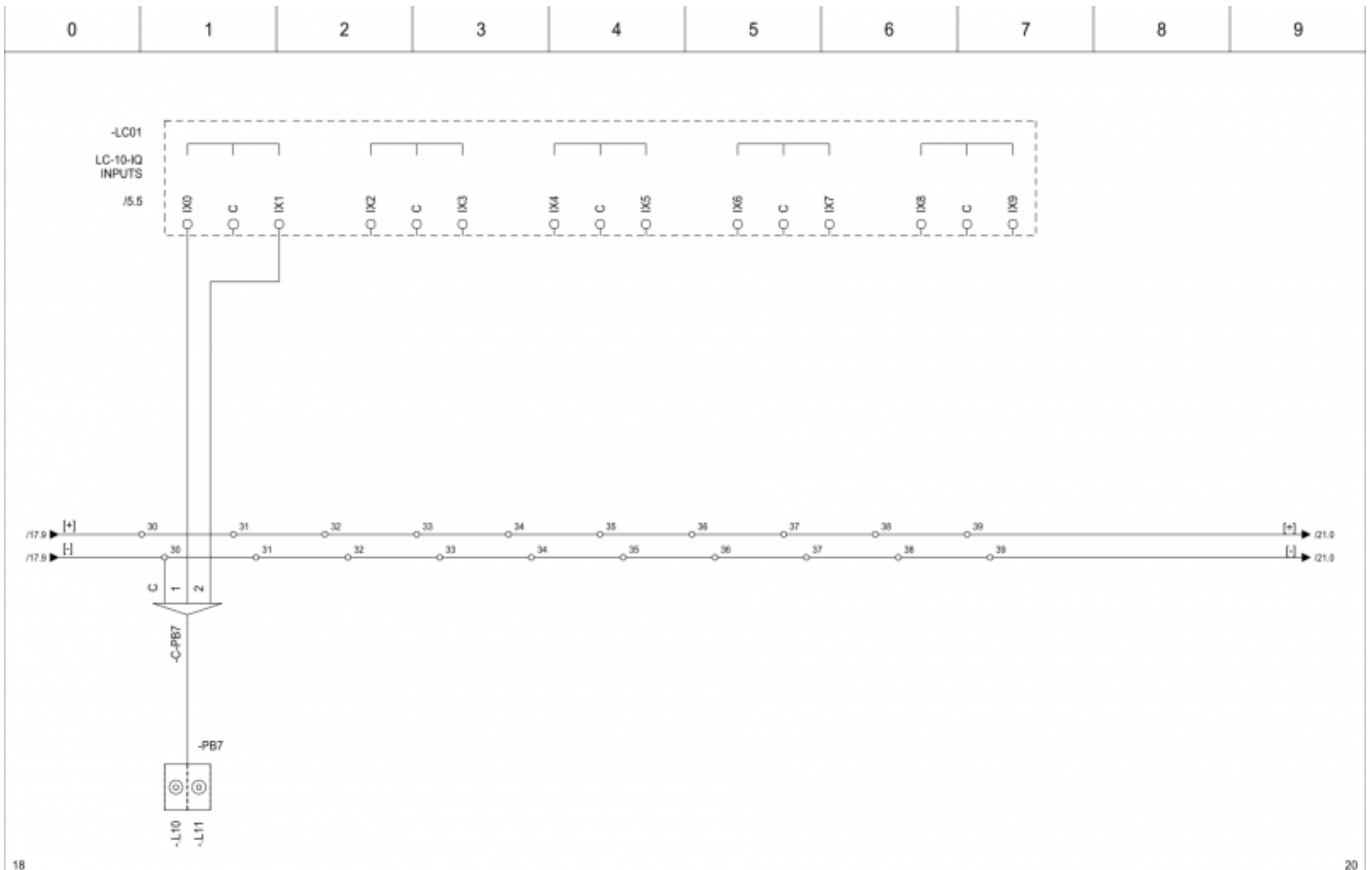

			Last changed to: GK Last changed: 20/10/2016 Drawn by: S/11/2016		Robotina d.o.o. OIC Kozina 38 SI-6240 Kozina	LIGHT CONTROLLER			Drawing number: 001 Installation: =		
Rev			Signature			HIQ wiring diagrams			Pages: 38 Location: +		
0			1		2			3		4	
5			6		7			8		9	

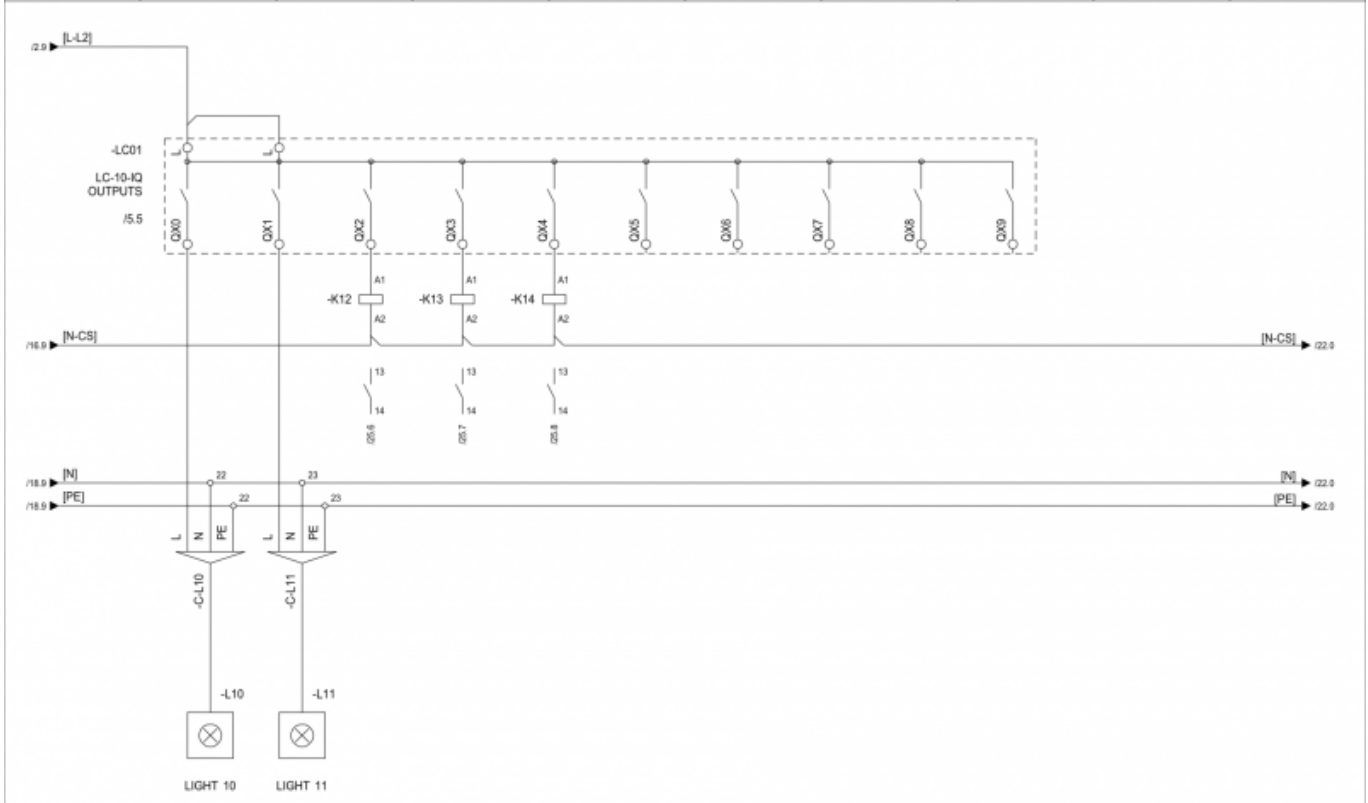

			Last changed to: SS Last changed: S/11/2016 Drawn by: S/11/2016		Robotina d.o.o. OIC Kozina 38 SI-6240 Kozina	LIGHT CONTROLLER			Drawing number: 001 Installation: =		
Rev			Signature			HIQ wiring diagrams			Pages: 38 Location: +		
0			1		2			3		4	
5			6		7			8		9	

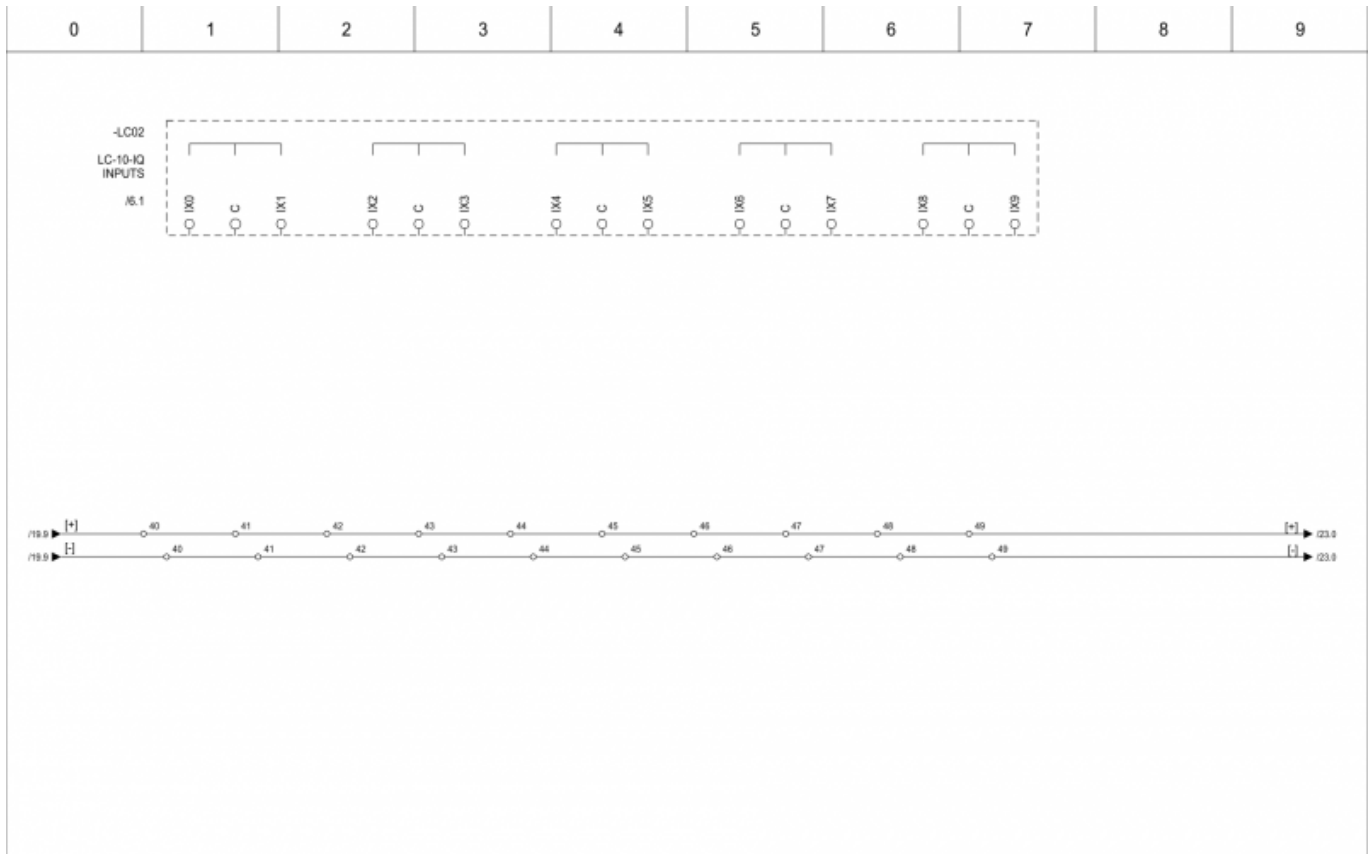

			Last changed by GK Last changed 20/10/2016 Print date 9/11/2016		Robotina d.o.o. OIC Kozina 38 SI-6240 Kozina	LIGHT CONTROLLER HIQ wiring diagrams		Drawing number 001 Pages 38		Installation = Location + Page number 21	
Rev	Revision text	Signature	Date								

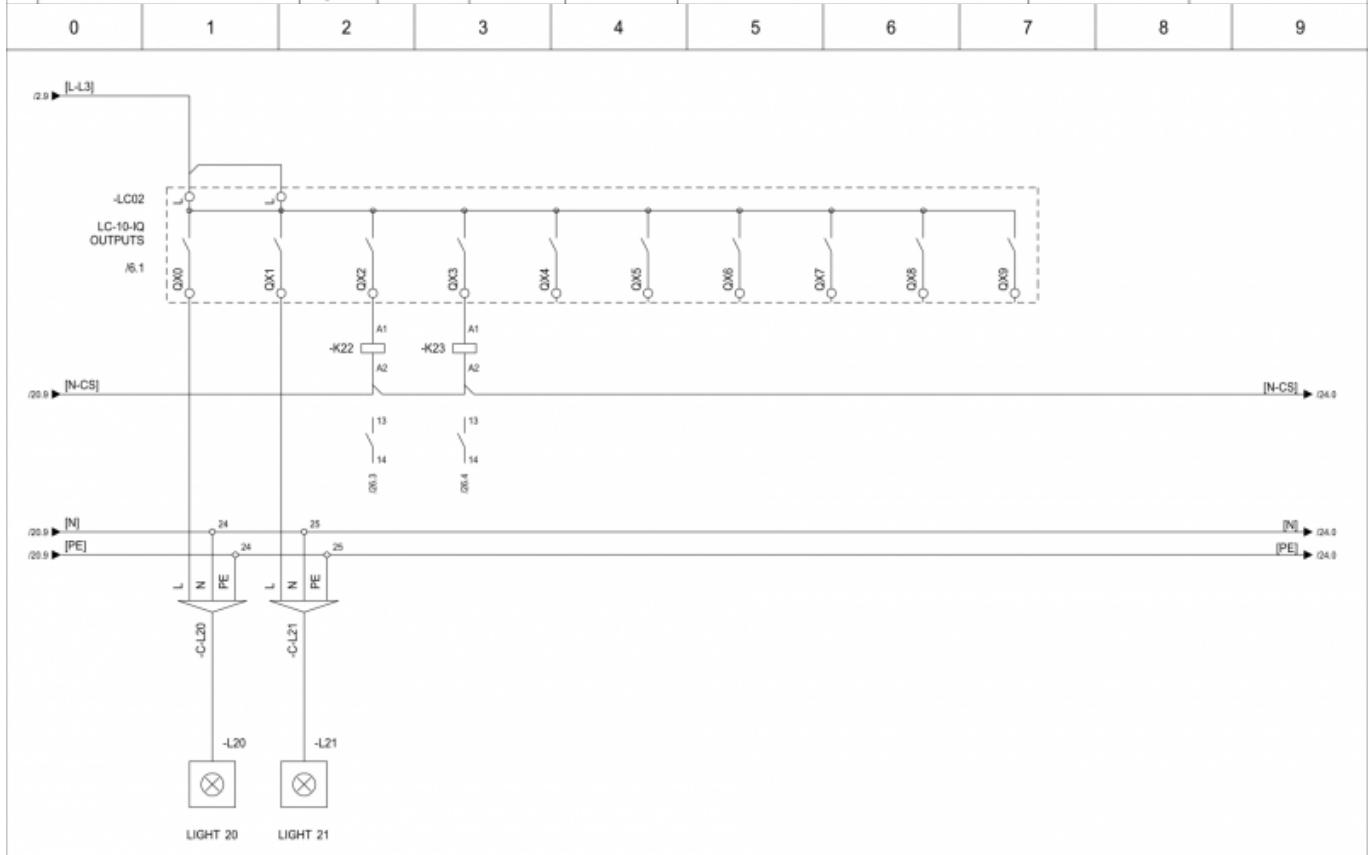

			Last changed by GK Last changed 2/11/2016 Print date 9/11/2016		Robotina d.o.o. OIC Kozina 38 SI-6240 Kozina	LIGHT CONTROLLER HIQ wiring diagrams		Drawing number 001 Pages 38		Installation = Location + Page number 22	
Rev	Revision text	Signature	Date								

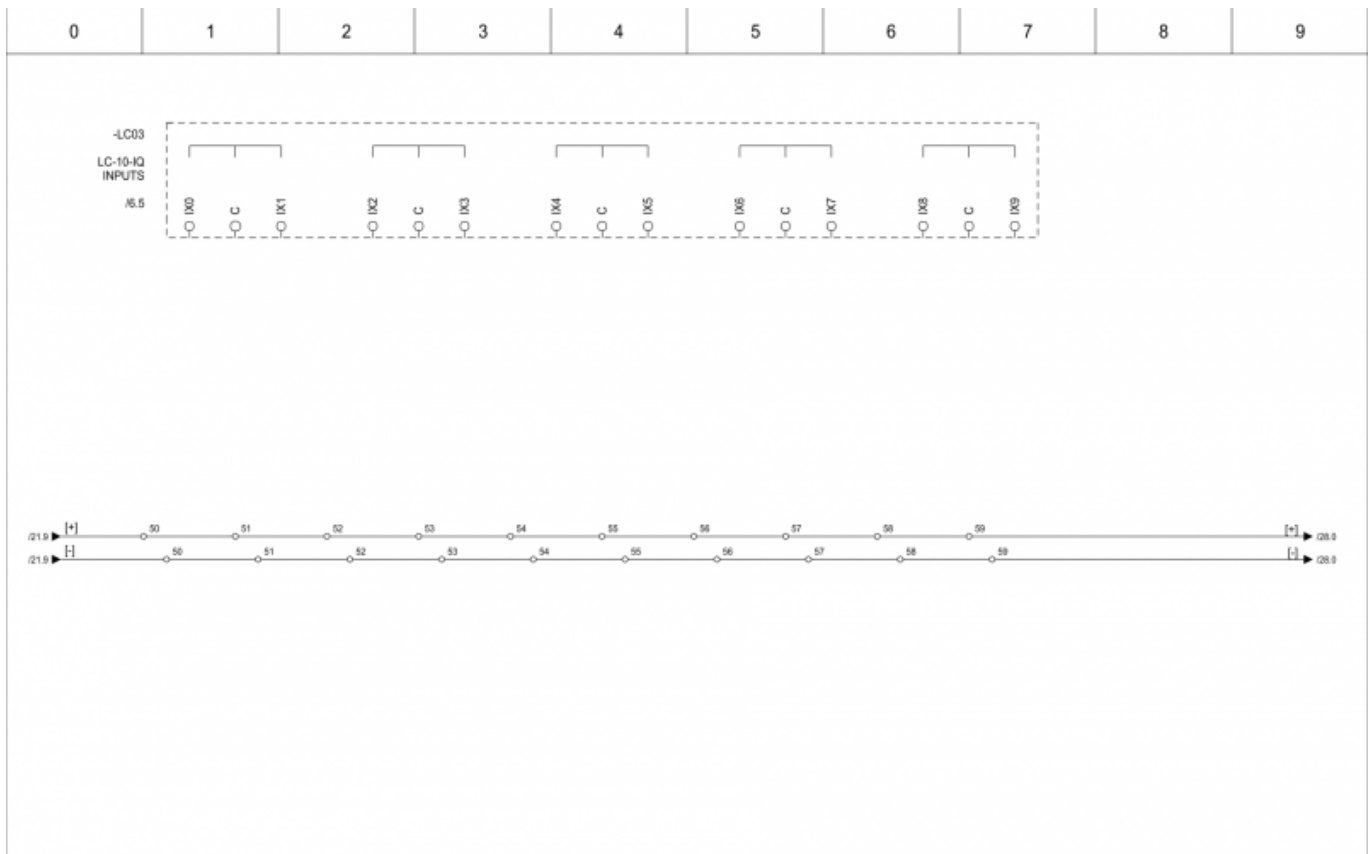

22 24

			Last changed by GK		 Robotina d.o.o. OIC Kozina 38 SI-6240 Kozina	LIGHT CONTROLLER		Drawing number 001		Installation =	
			Last changed 20/10/2016			HIQ wiring diagrams		Pages 38		Location +	
Rev	Revision text	Signature	Date	9/11/2016				Page number 23			
0	1	2	3	4	5	6	7	8	9		

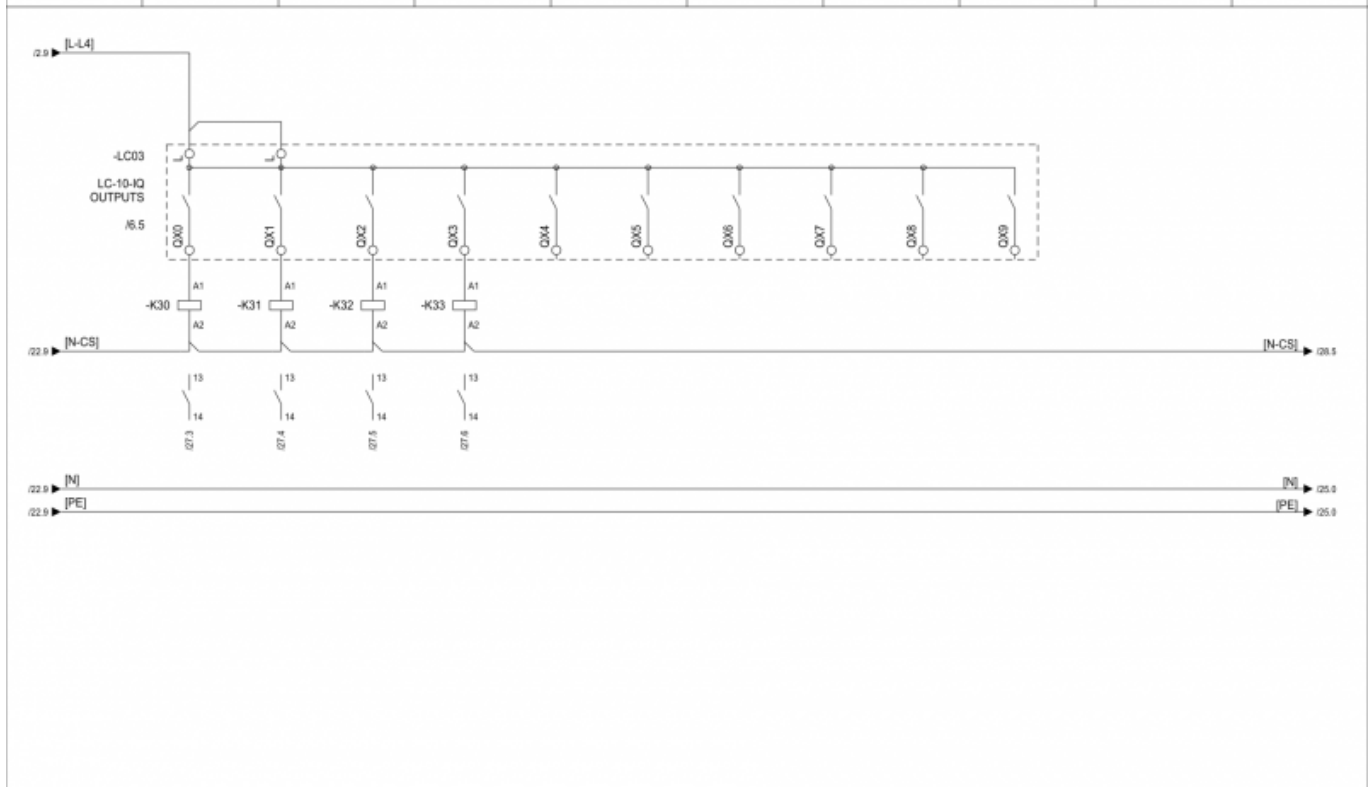

23 25

			Last changed by GK		 Robotina d.o.o. OIC Kozina 38 SI-6240 Kozina	LIGHT CONTROLLER		Drawing number 001		Installation =	
			Last changed 2/11/2016			HIQ wiring diagrams		Pages 38		Location +	
Rev	Revision text	Signature	Date	9/11/2016				Page number 24			
0	1	2	3	4	5	6	7	8	9		

Page 25-27 - Power sockets

A sample plan assumes use of managed and unmanaged sockets. Managed sockets are connected to [Light controllers](#). External installation relays should be used on Light controller outputs.

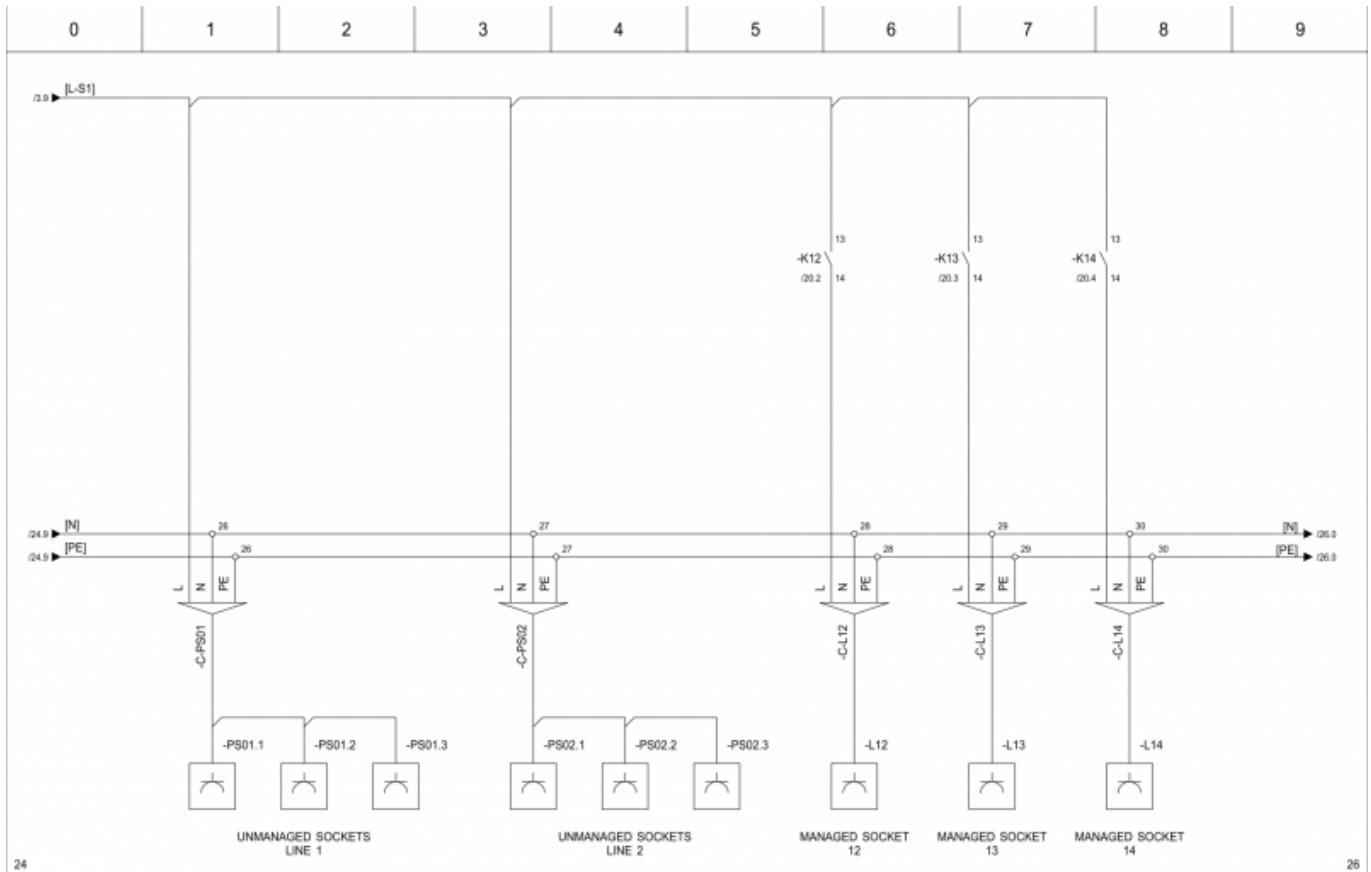

24										26		
			Last changed by: GK Last changed: 2/11/2016 Per date: 9/11/2016		Robotina d.o.o. OIC Kozina 38 SI-6240 Kozina		POWER SOCKETS HIQ wiring diagrams		Drawing number 001		Installation = Location +	
Rev			Revision text		Signature		Date		Pages 38		Page number 25	

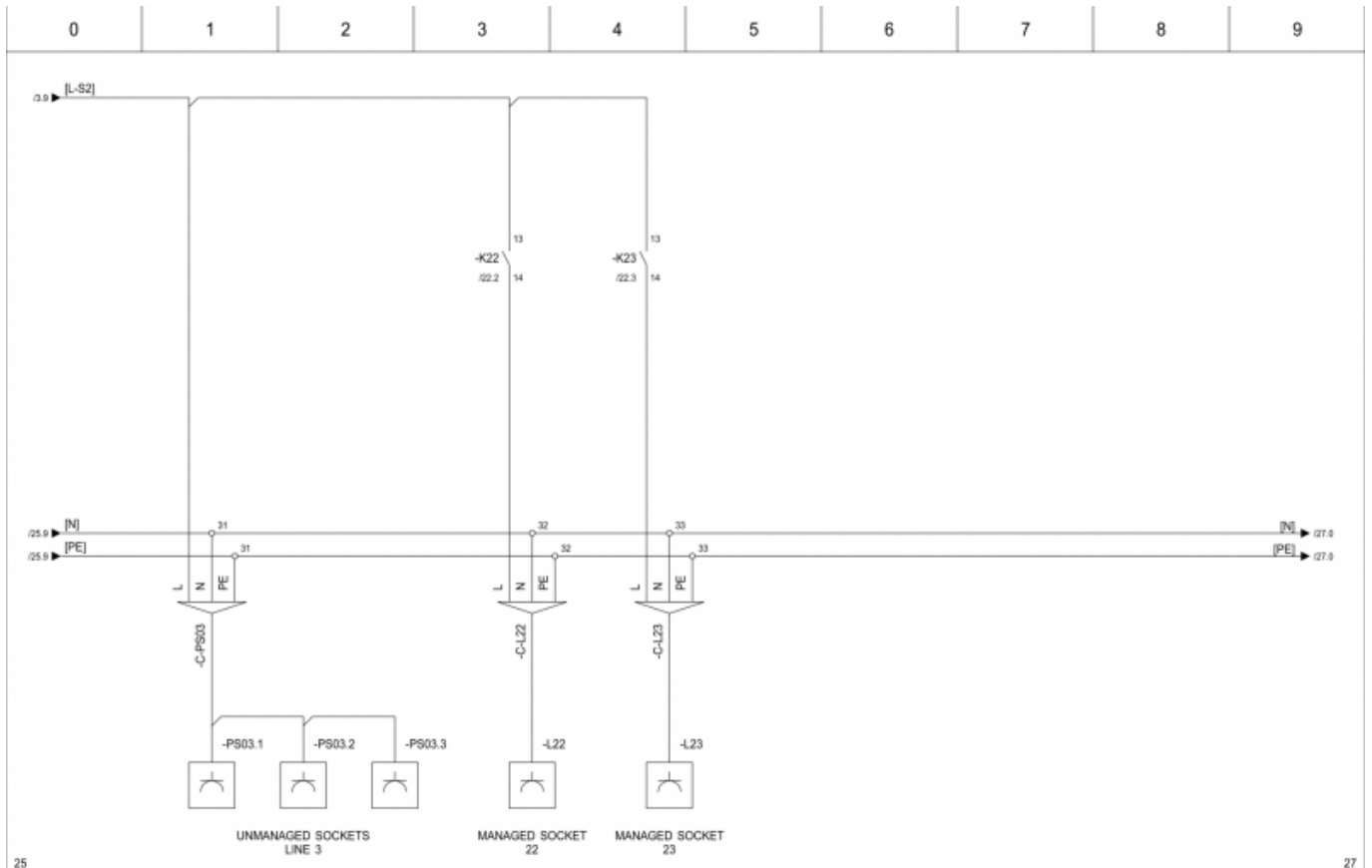

			Last changed by GK		 Robotina d.o.o. OIC Kozina 38 SI-6240 Kozina	POWER SOCKETS		Drawing number 001		Installation =	
			Last changed 2/11/2016			HIQ wiring diagrams		Pages 38		Location +	
Rev		Revision text		Signature		Date		9/11/2016		Page number 26	
0	1	2	3	4	5	6	7	8	9		

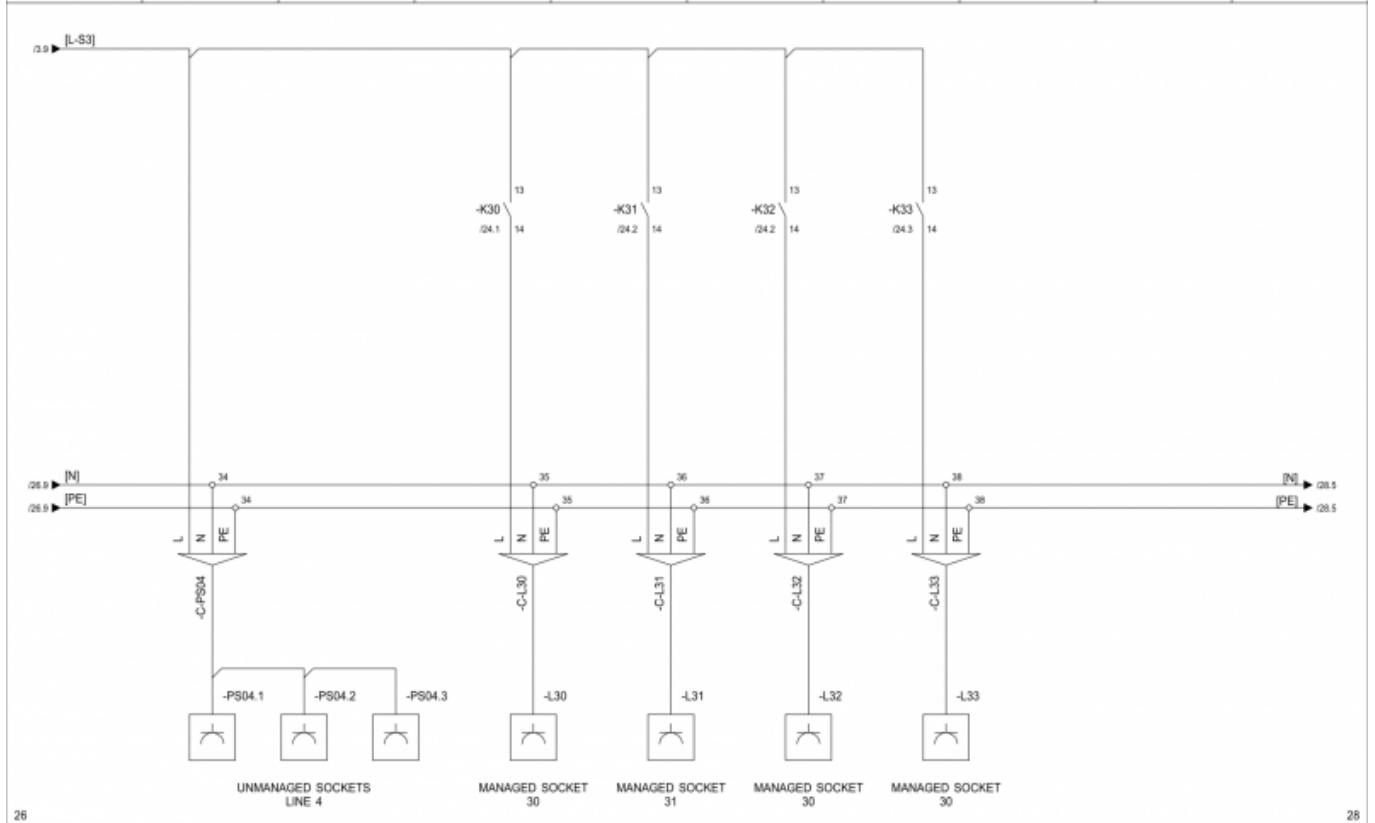

			Last changed by GK		 Robotina d.o.o. OIC Kozina 38 SI-6240 Kozina	POWER SOCKETS		Drawing number 001		Installation =	
			Last changed 2/11/2016			HIQ wiring diagrams		Pages 38		Location +	
Rev		Revision text		Signature		Date		9/11/2016		Page number 27	
0	1	2	3	4	5	6	7	8	9		

Page 28-29 - Light dimmers

On sample plan we use 2 Light dimmers drivers. On each driver we can connect up to 4 LUD-12 universal light dimmers.

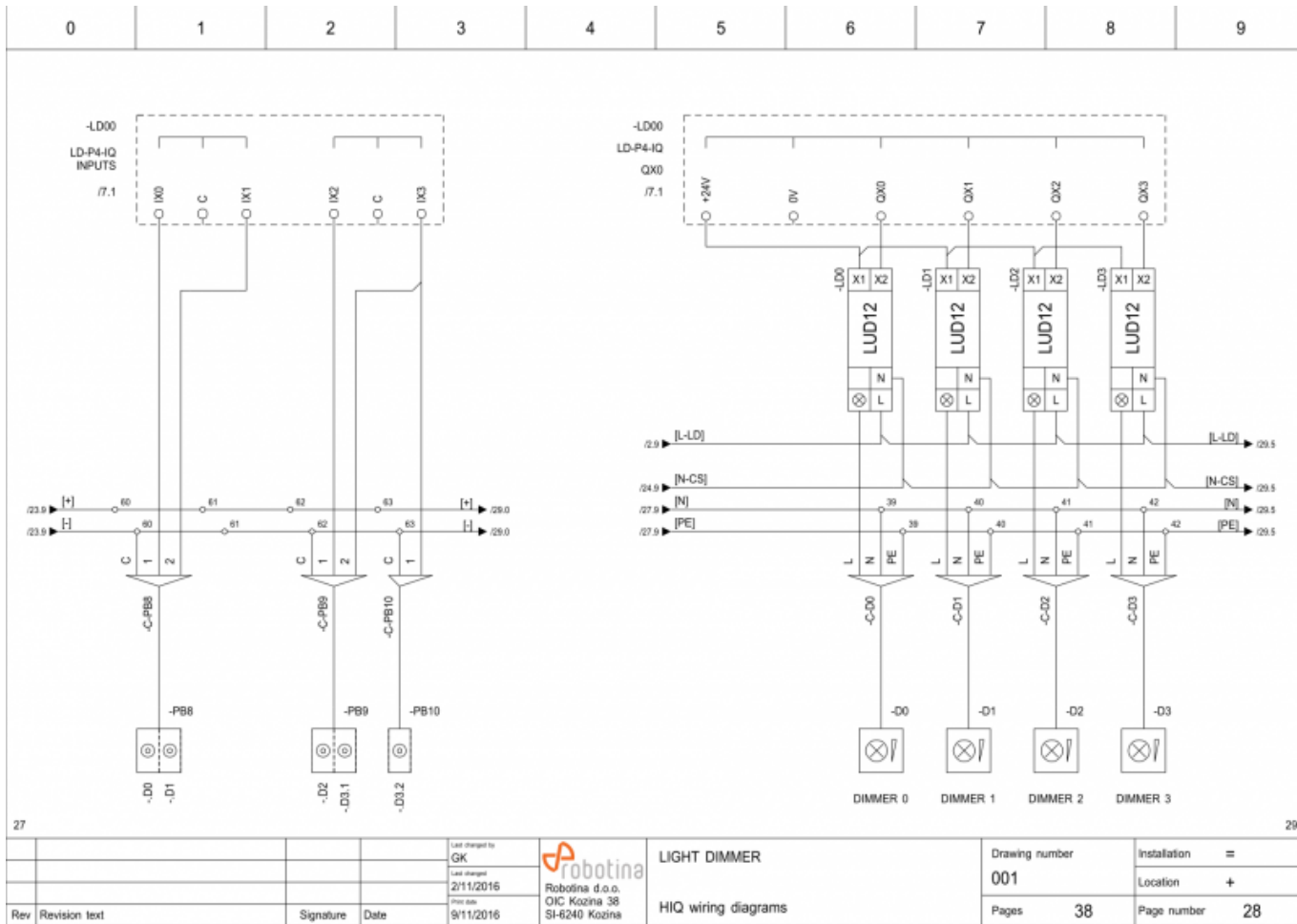

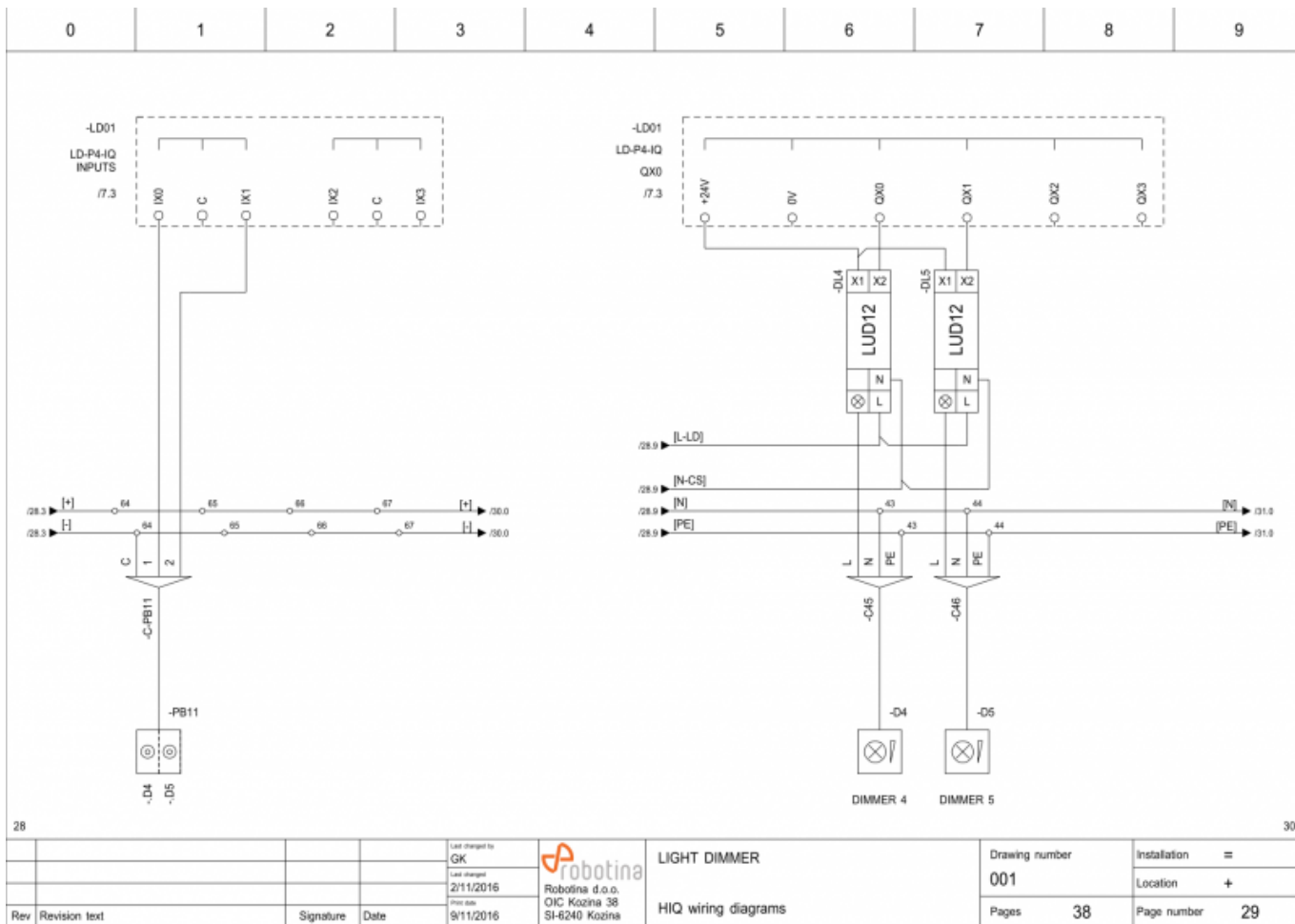

Page 30-33 - Blinds controllers

On our sample plan we have 2 [Blinds controllers \(BC\)](#) with 9 blinds and 9 double-push buttons.

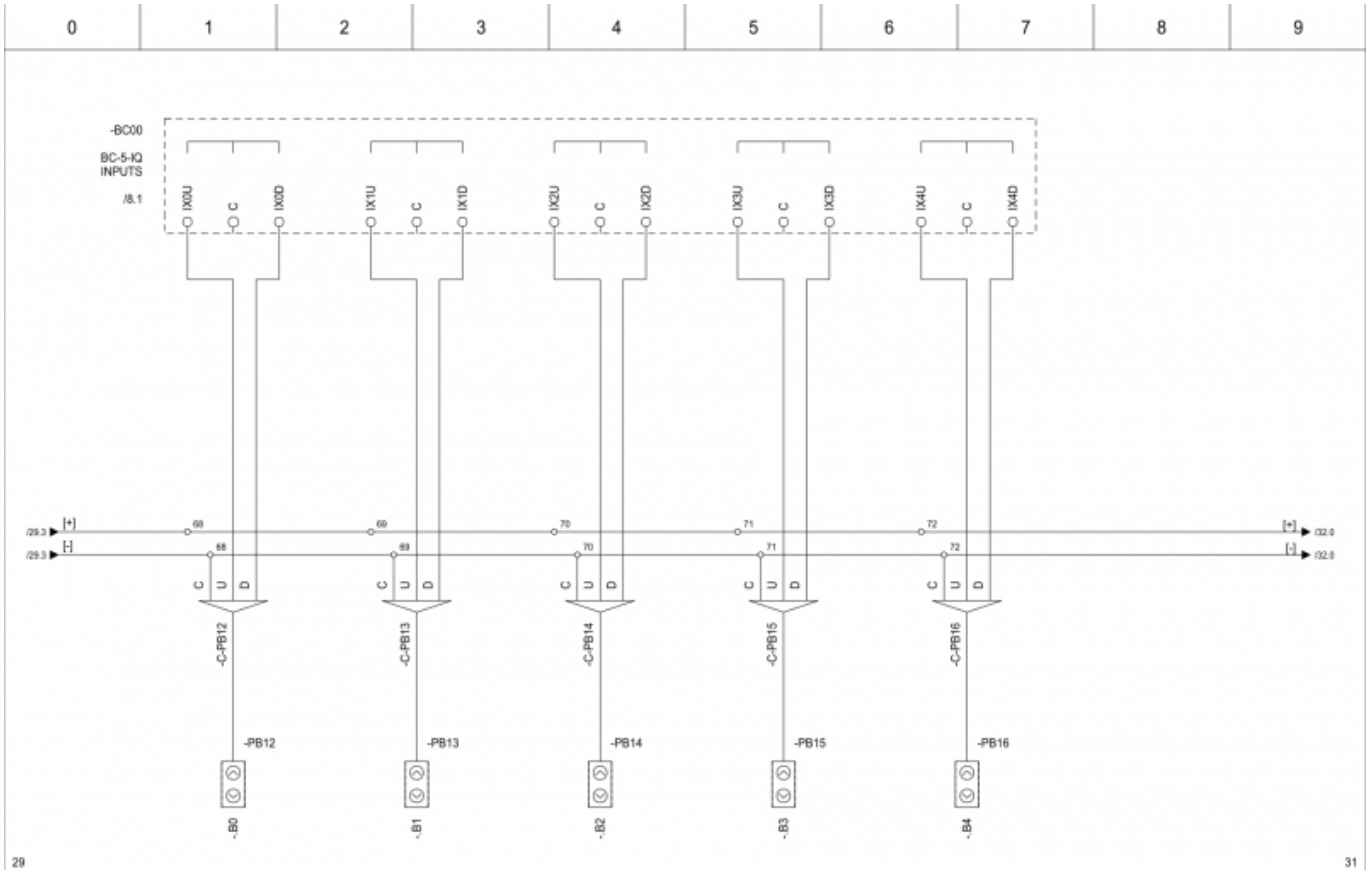

			Last changed by GK Last changed 20/10/2016 Print date 9/11/2016		Robotina d.o.o. OIC Kozina 38 SI-6240 Kozina	BLINDS CONTROLLER HIQ wiring diagrams		Drawing number 001		Installation =	
Rev			Signature			Date		Pages 38		Location +	
Revision text								Page number 30			

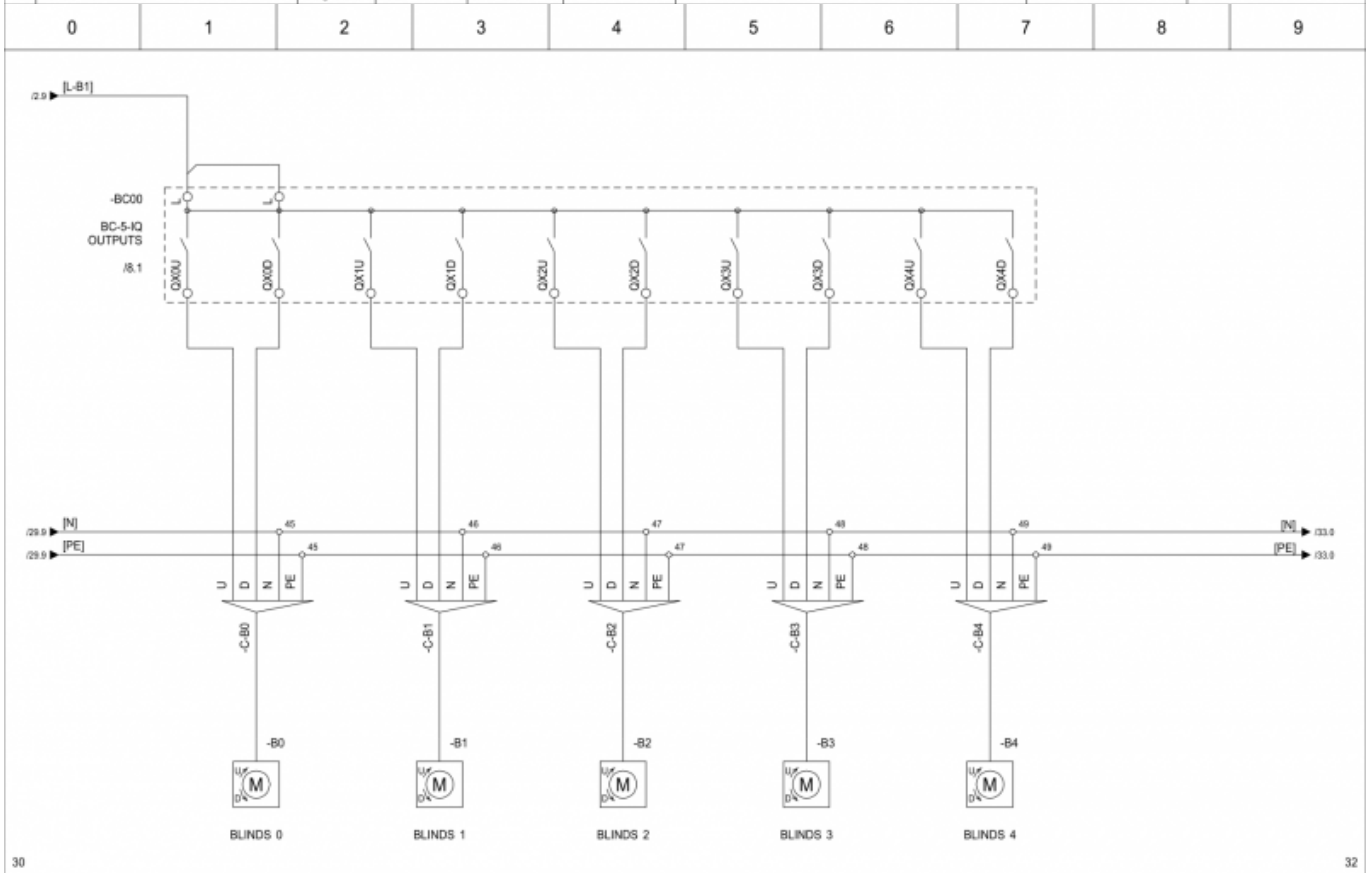

			Last changed by GK Last changed 2/11/2016 Print date 9/11/2016		Robotina d.o.o. OIC Kozina 38 SI-6240 Kozina	BLINDS CONTROLLER HIQ wiring diagrams		Drawing number 001		Installation =	
Rev			Signature			Date		Pages 38		Location +	
Revision text								Page number 31			

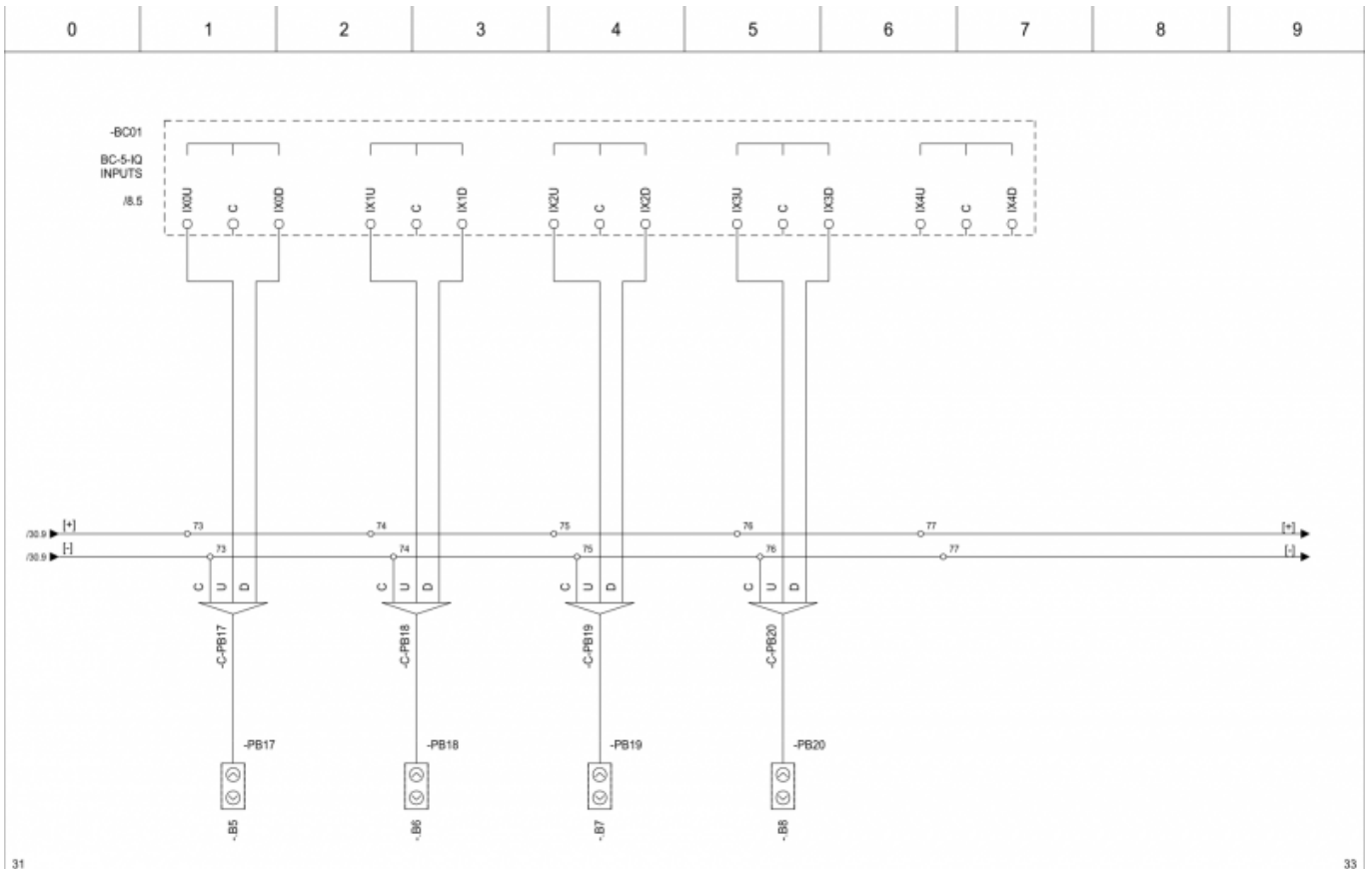

31 33

				Last changed by GK Last changed 20/10/2016 Drawn by 9/11/2016	 Robotina d.o.o. OIC Kozina 38 SI-6240 Kozina	BLINDS CONTROLLER HIQ wiring diagrams		Drawing number 001 Pages 38	Installation = Location + Page number 32
Rev	Revision text	Signature	Date						

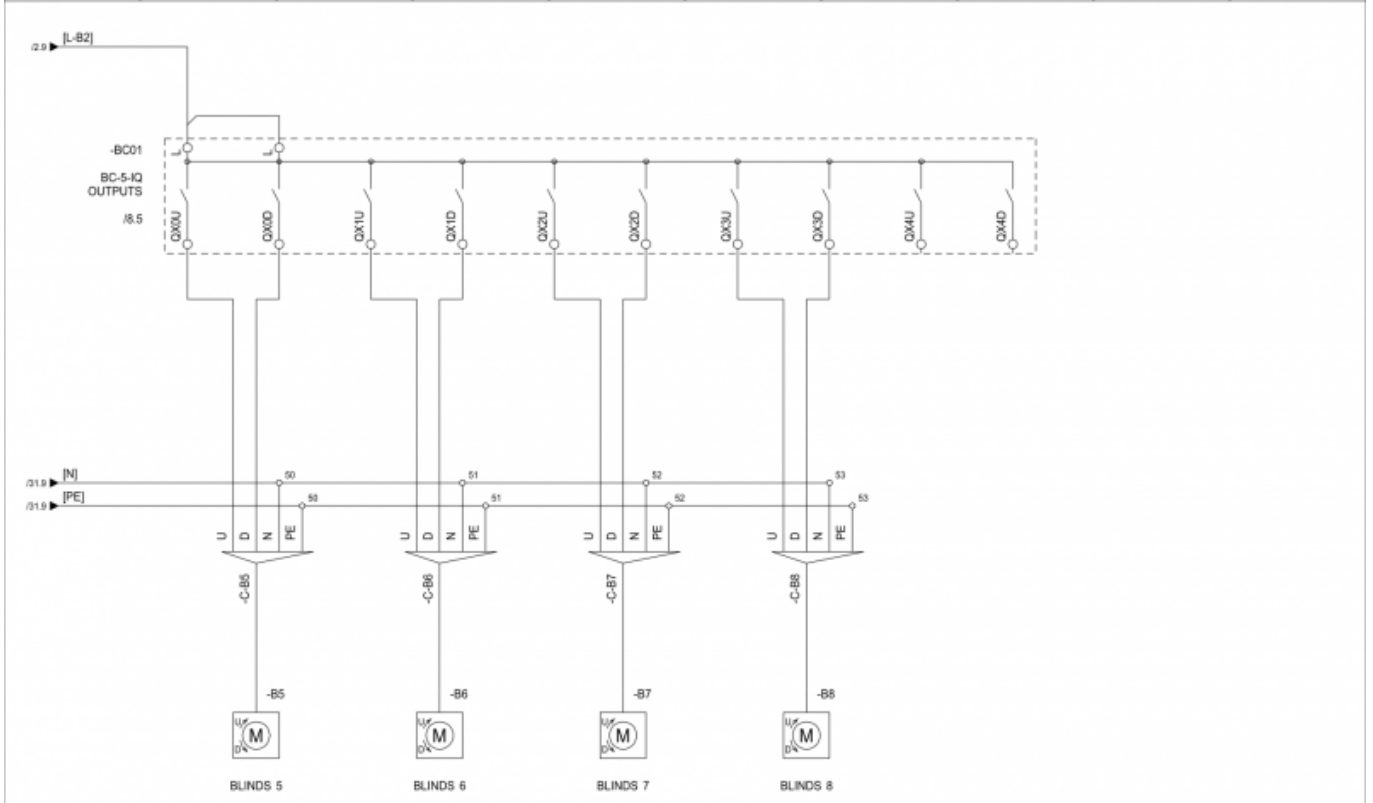

32 34

				Last changed by GK Last changed 2/11/2016 Drawn by 9/11/2016	 Robotina d.o.o. OIC Kozina 38 SI-6240 Kozina	BLINDS CONTROLLER HIQ wiring diagrams		Drawing number 001 Pages 38	Installation = Location + Page number 33
Rev	Revision text	Signature	Date						

Page 34-35 - LED stripe dimmer

On sample plan we use 2 LED stripe dimmers. RGBW (red-green-blue-white) LED stripe is connected on the first dimmer and the second dimmer controls 2 white LED stripes (2 outputs are empty). 2 push buttons are connected on the second dimmer.

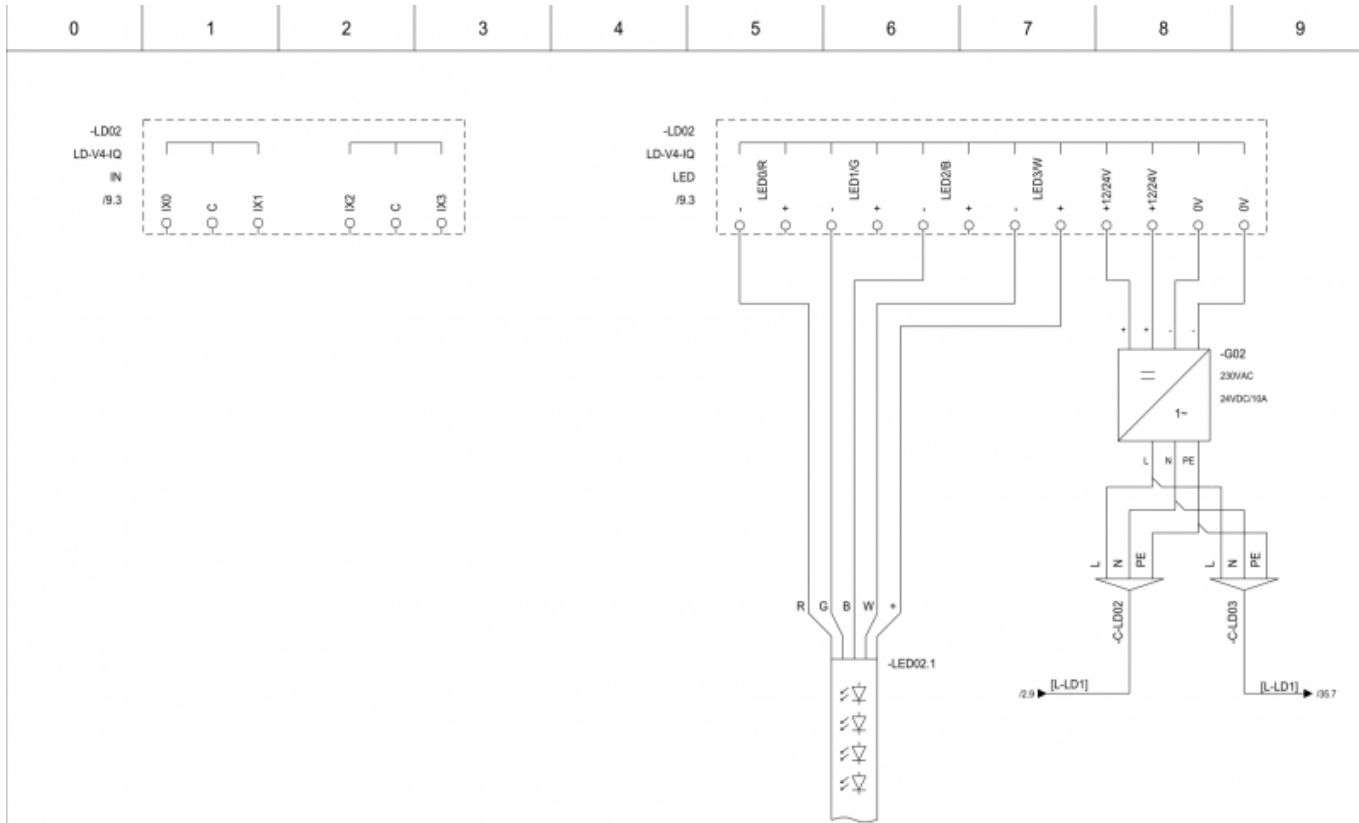

33

35

				Last changed by SS	 Robotina d.o.o. OIC Kozina 38 SI-6240 Kozina	LIGHT DIMMER	Drawing number	Installation =	
				Last changed 9/11/2016				001	Location +
Rev	Revision text	Signature	Date	Print date 9/11/2016			HIQ wiring diagrams	Pages 38	Page number 34

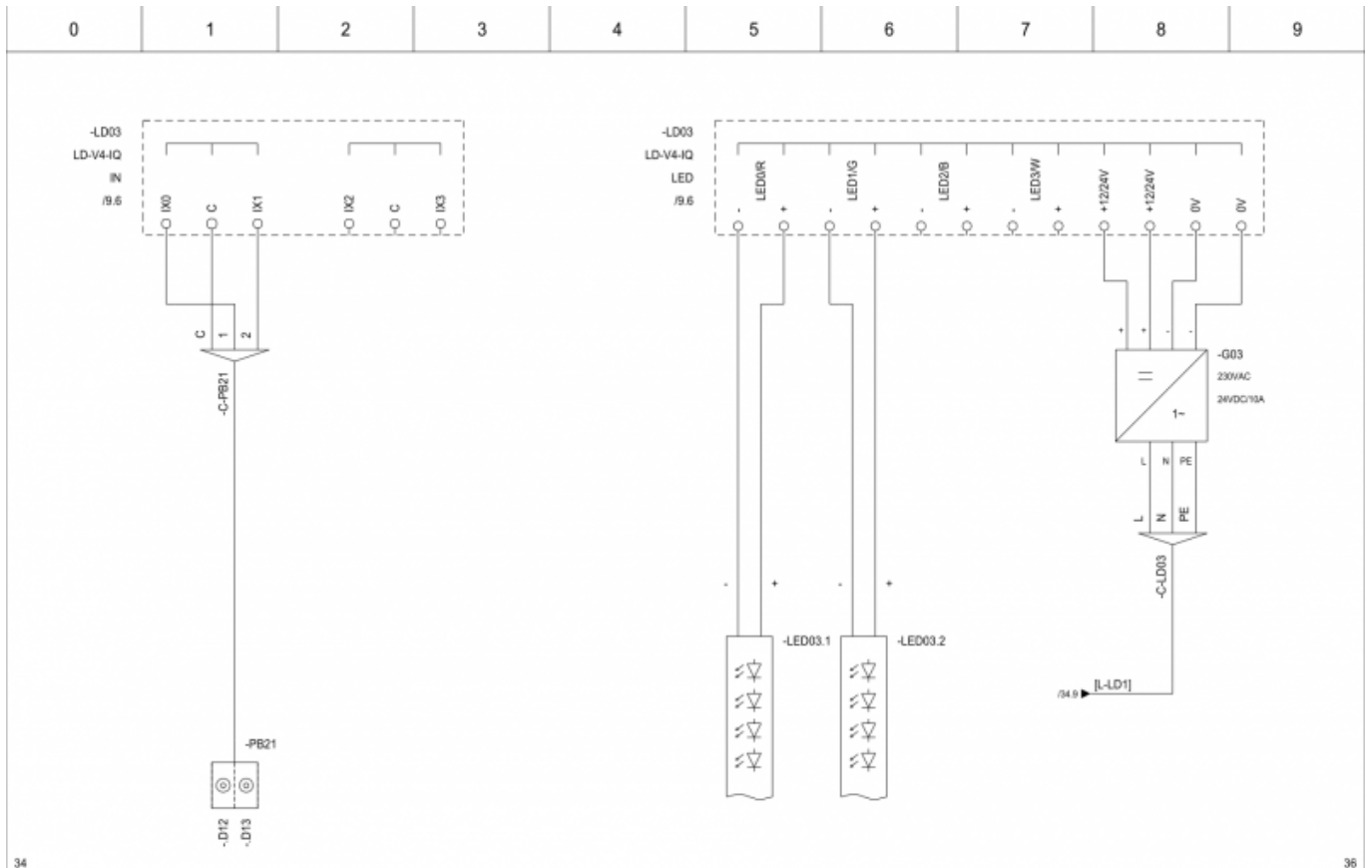

				Let changed to SS	 Robotina d.o.o. OIC Kozina 38 SI-6240 Kozina	LIGHT DIMMER	Drawing number	Installation	=	
				Let changed 9/11/2016		HIQ wiring diagrams	001	Location	+	
Rev	Revision text	Signature	Date	9/11/2016			Pages	38	Page number	35

Page 36-38 - Fan-coil

Fan-coil connection.

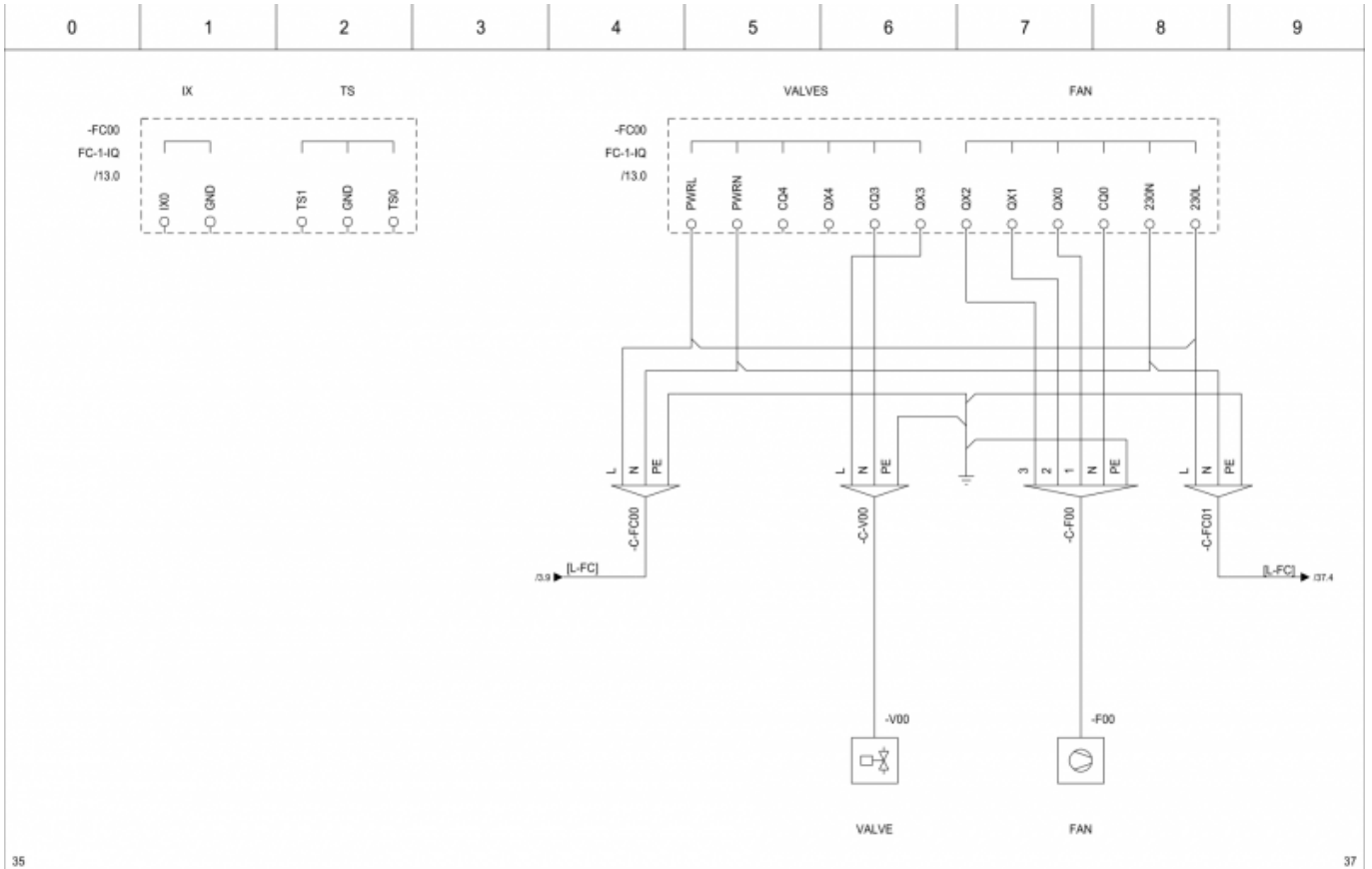

			Last changed by SS Last changed 9/11/2016 Draw date 9/11/2016		Robotina d.o.o. OIC Kozina 38 SI-6240 Kozina	FAN-COIL HIQ wiring diagrams		Drawing number 001 Pages 38		Installation = Location + Page number 36	
Rev	Revision text	Signature	Date								

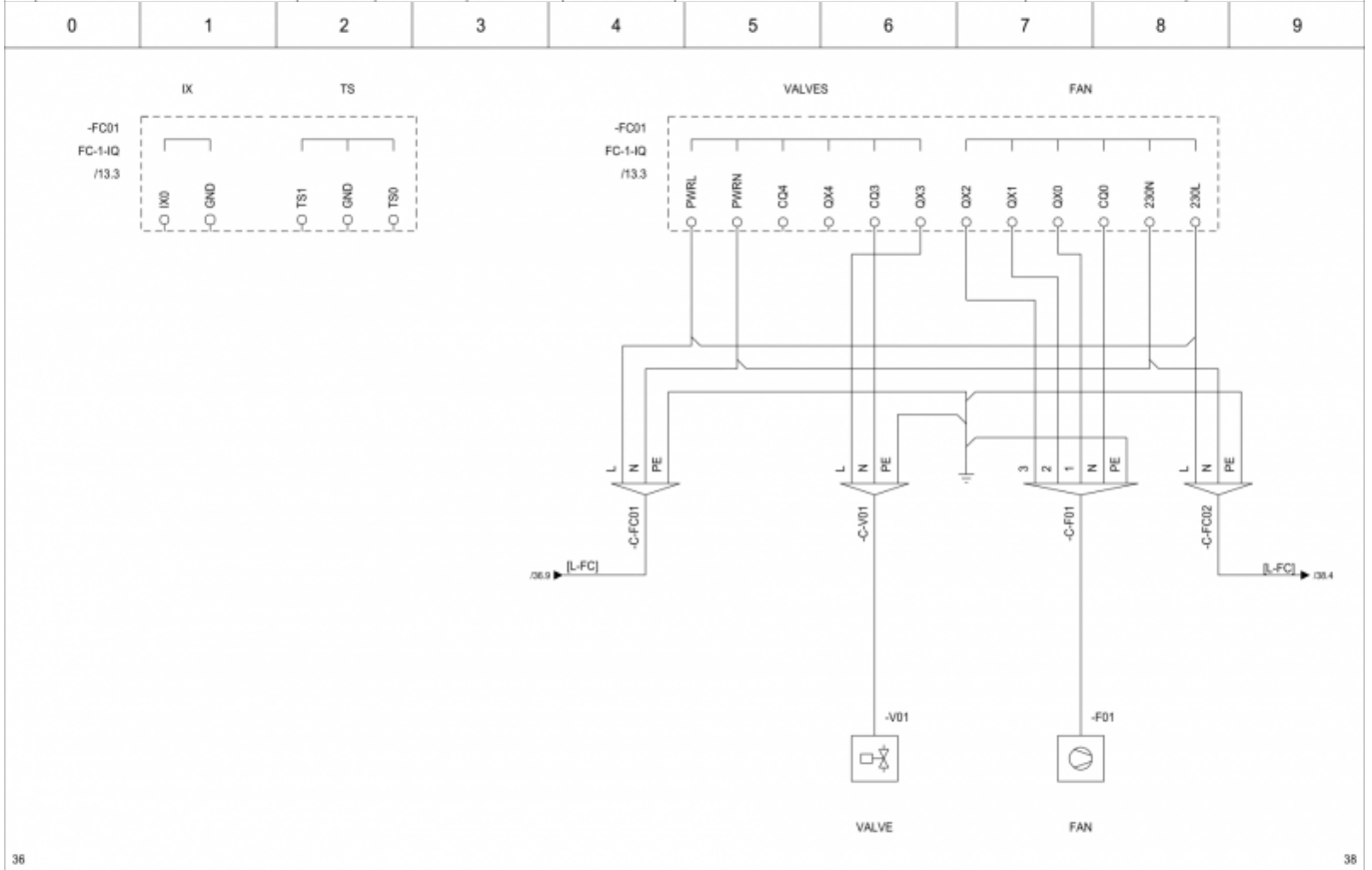

			Last changed by SS Last changed 9/11/2016 Draw date 9/11/2016		Robotina d.o.o. OIC Kozina 38 SI-6240 Kozina	FAN-COIL HIQ wiring diagrams		Drawing number 001 Pages 38		Installation = Location + Page number 37	
Rev	Revision text	Signature	Date								

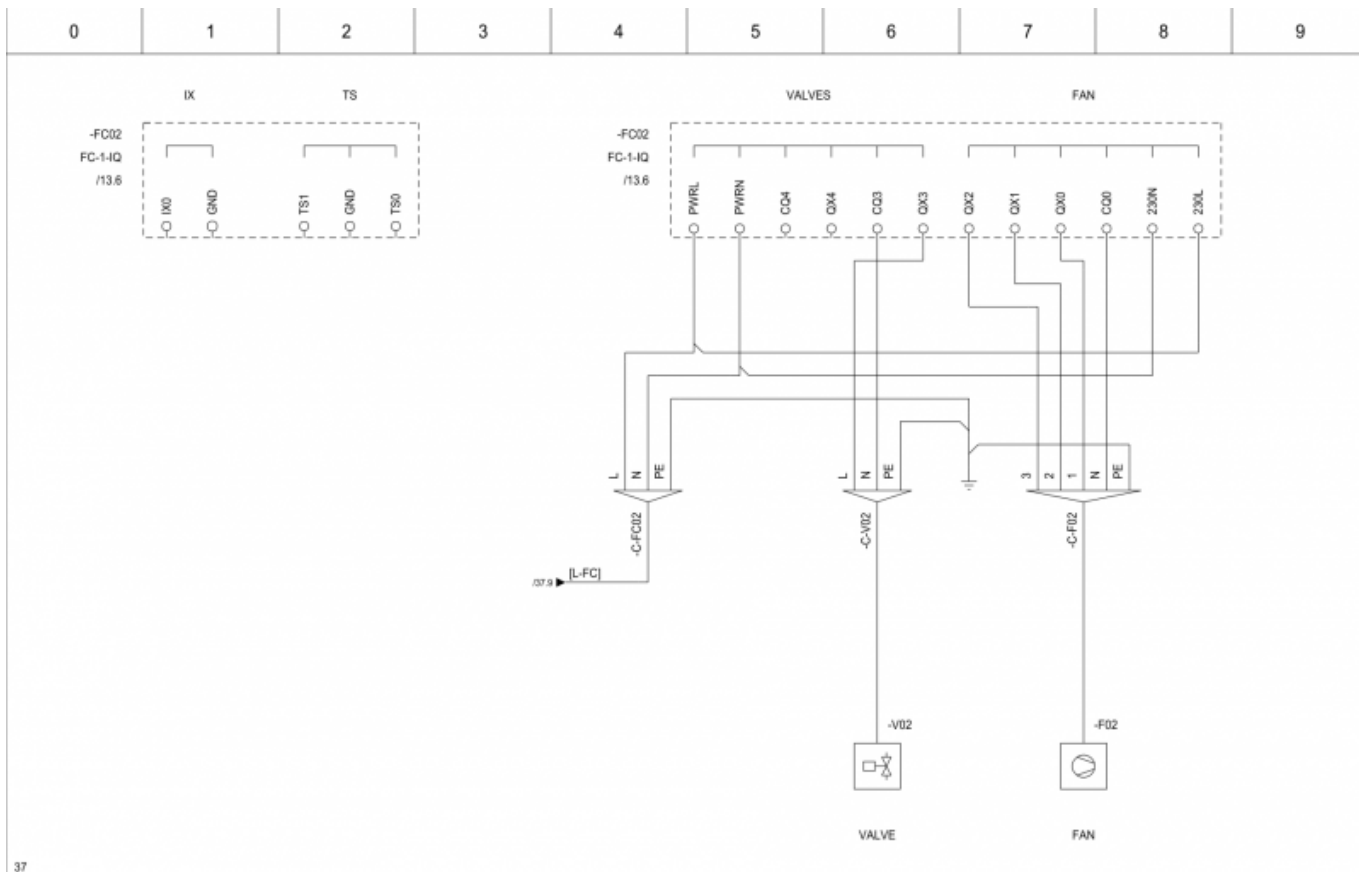

37

				Last changed by GK	 Robotina Robotina d.o.o. OIC Kozina 38 SI-6240 Kozina	FAN-COIL	Drawing number	Installation	=	
				Last changed 2/11/2016		HIQ wiring diagrams	001	Location	+	
Rev	Revision text	Signature	Date	9/11/2016			Pages	38	Page number	38

From:
<https://wiki.hiq-home.com/> -

Permanent link:
https://wiki.hiq-home.com/doku.php?id=en:hiq_home:methods:design&rev=1538745084

Last update: **2018/10/05 13:11**

