

TEM

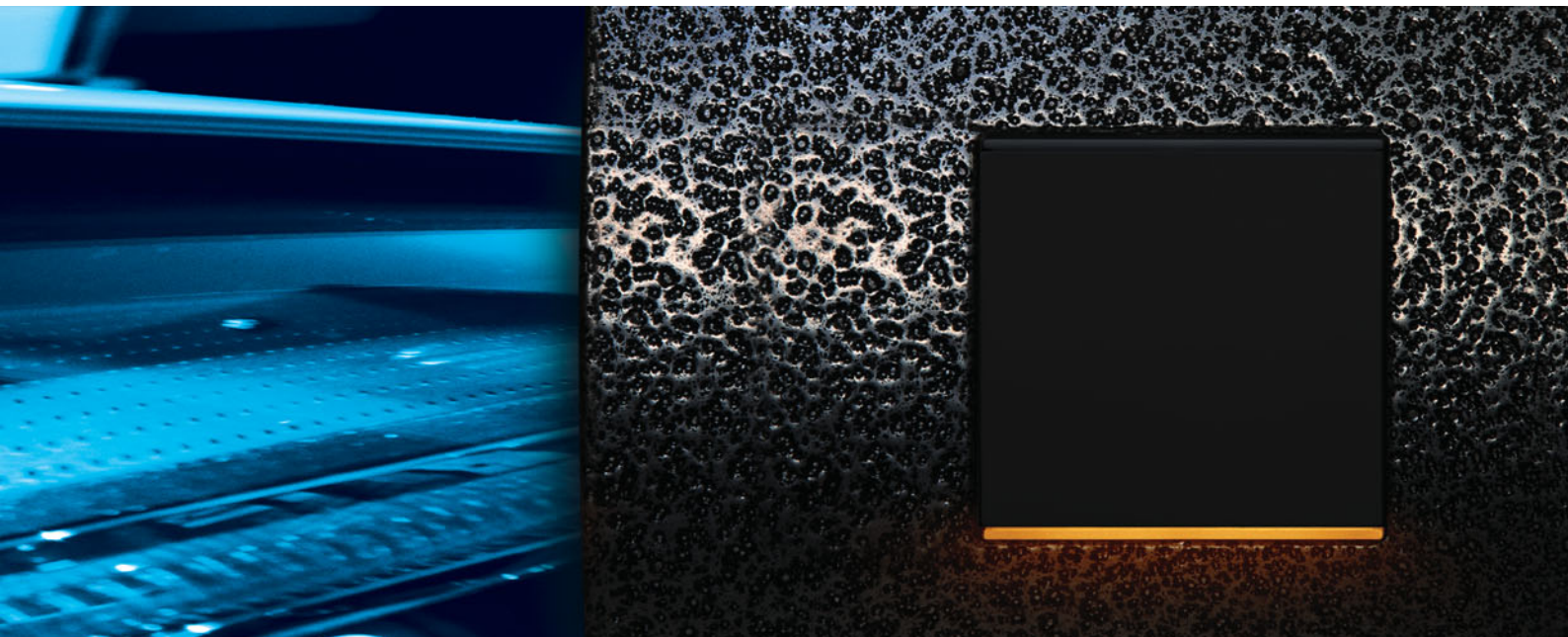

touching completeness

TEM

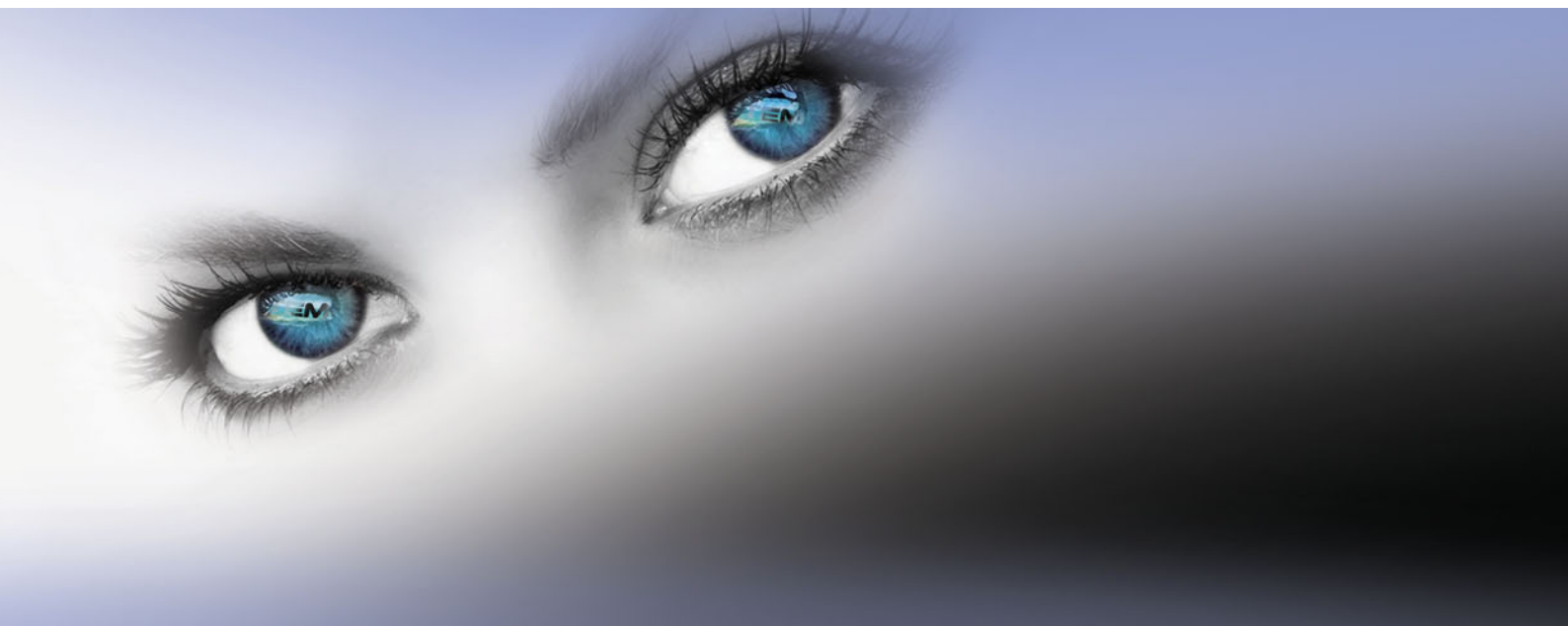

Dobrodošli v družini **MODUL**

Welcome to the **MODUL** family

Za vas dopolnjujemo in izpopolnjujemo
sodobno družino stikal Modul za vse vrste vaših prostorov.

We are expanding and perfecting the modern
Modul switch family for all types of rooms.

discovering new insights

odkrivamo nove poglede

MODUL

Oblikovne linije Pure, Line in Soft so odraz sodobnega, prefinjenega in individualnega življenjskega stila. Iz široke in bogate palete barv, vzorcev in oblik lahko svoja stikala in vtičnice kadarkoli preprosto prilagodite zelenemu ambientu in razpoloženju.

The Pure, Line and Soft design lines reflect a modern, sophisticated and independent lifestyle. You can choose from a wide and rich selection of colours, patterns and shapes to alter the appearance of your switches and sockets so that they fit the desired atmosphere and mood.

PURE

naravni materiali
natural materials

les wood
kovina metal
steklo glass

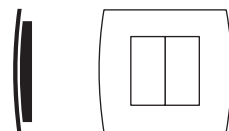

—line—



ravne linije
straight lines

—soft—



mehke linije
soft lines

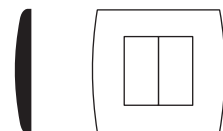
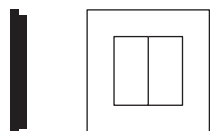

PURE



čudovito bivanje wonderful living

Iz čistih, neomadeževanih podob na novo rojenega sveta je vzklila zgodba Pure. Dotik naravnih motivov smo prepletli s prefinjenim okusom za linije in obliko ter vtkali niti vrhunske tehnologije.

From the cleanliness and purity of a new-born world stems the story of the Pure line. The touch of natural motifs is intertwined with a sophisticated taste for lines and form and interwoven with threads of state-of-the-art technology.



PURE

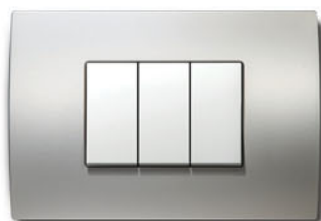
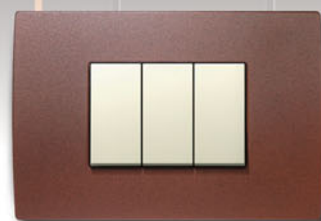
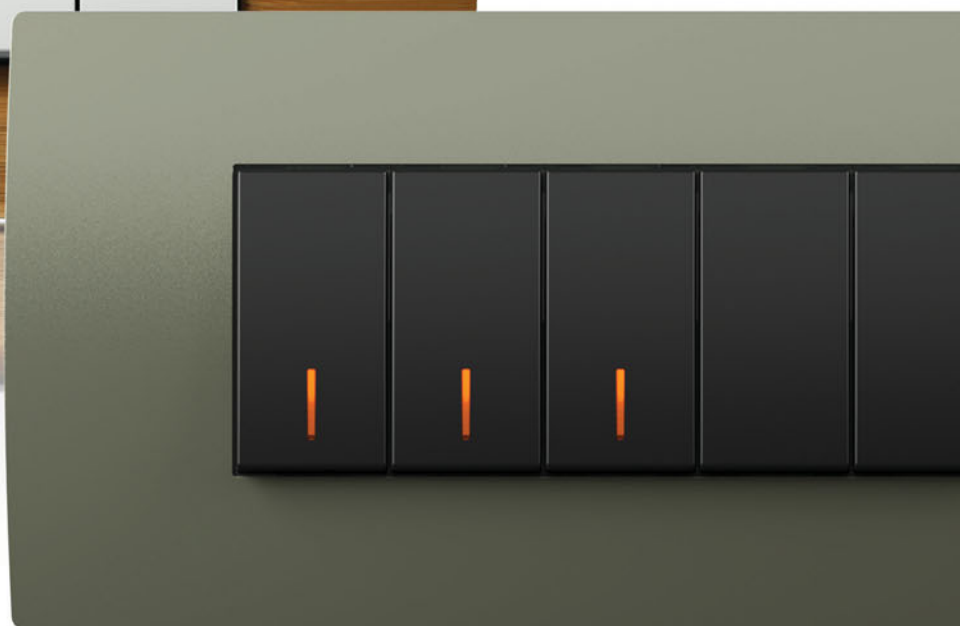



občutek narave feeling of nature

Linijo stikal Pure odlikujejo naravni materiali: kovina, les, steklo. Poseben dotik se izraža skozi edinstveno obliko. Je opazen, a hkrati nevsiljiv. Izžareva čutnost, prefinjenost, merila visokega standarda in seveda čistost.

The Pure switch line is distinguished by its natural materials: metal, wood and glass. Its unique design gives it a special touch. It is striking yet unobtrusive. It radiates sensuality, sophistication, high standards and, of course, cleanliness.

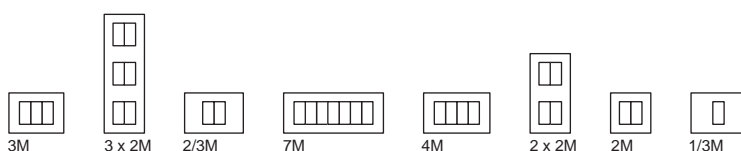

line



harmonija ravnih oblik harmony of straight lines

Pripravite se na elegantno popolnost ravnih oblik. Preizkusite sijajnost površin, ki se nežno poigravajo z modernimi elementi vašega prostora. Posebej za vas smo vgradili tehnologijo Soft Touch, da je vsak vaš dotik posebno doživetje.

Prepare for the elegant perfection of straight shapes. Try brilliant surfaces that gently play with modern elements of your room. We have incorporated "Soft Touch" technology especially for you, turning every touch into a unique experience.



line

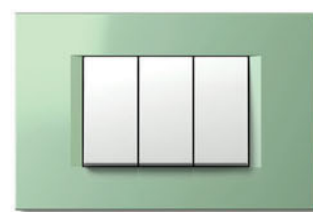
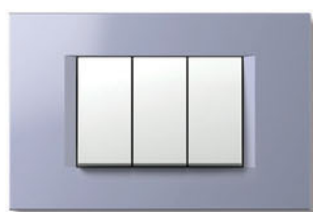
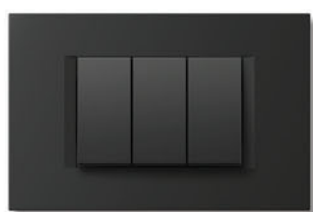
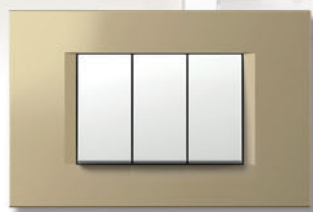
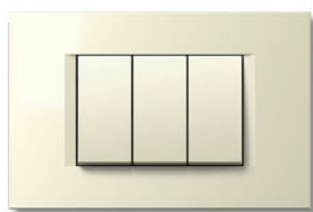
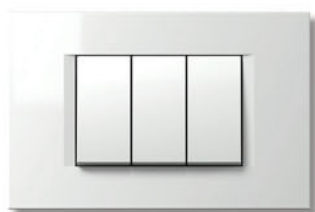
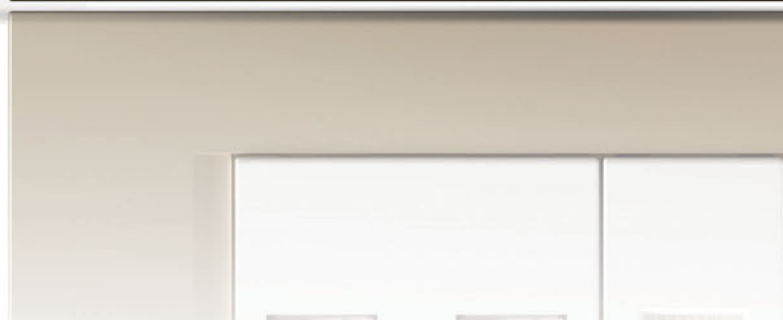
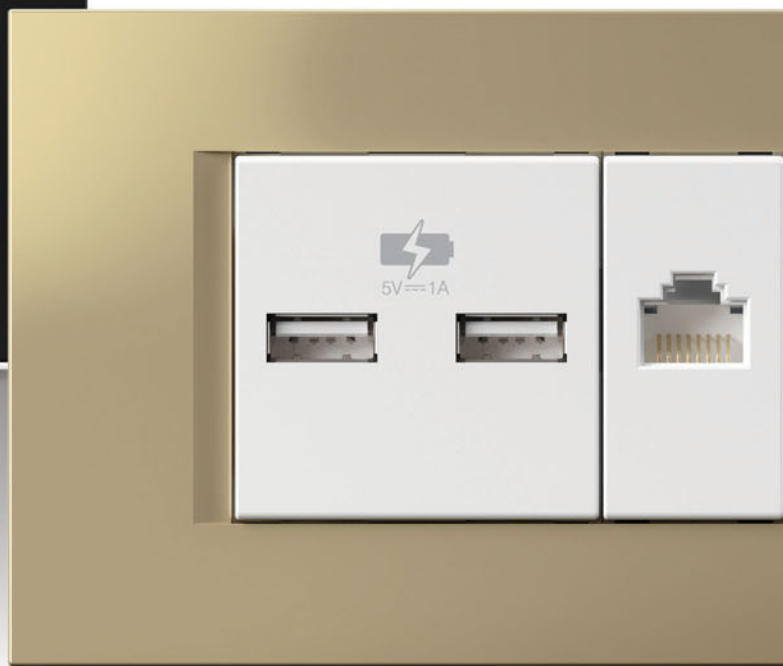

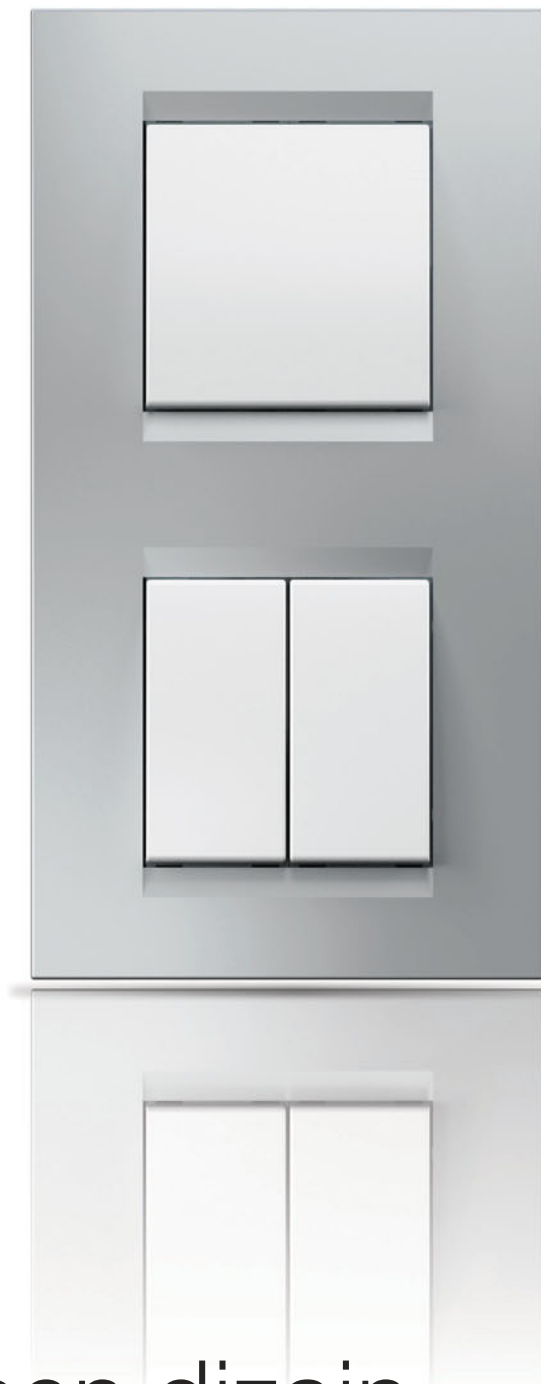
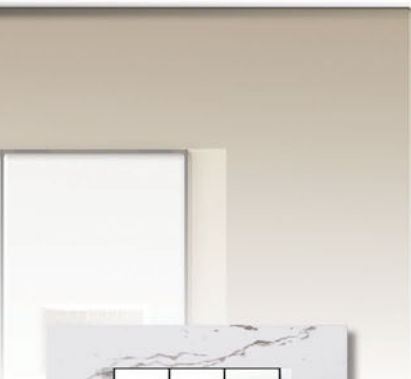

sodoben dizajn modern design

Čiste, ravne linije ustvarjajo brezčasen dizajn.
Popoln, ravno oblikovan tanek profil in ergonomija mehkega dotika dajeta vrhunski videz z vseh strani.

Its straight, smooth lines make for a timeless design.
Its perfectly straight, sleek profile and soft-touch ergonomics give it an amazingly elegant appearance from all angles.

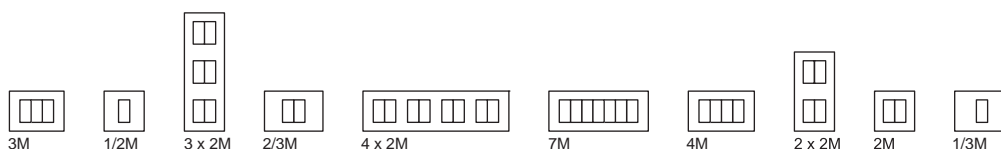

soft



mehkoba v vašem domu

softness in your home

Dovolite, da zaobljene oblike in nežni prehodi
prinesejo mehko v vaš dom.

Let the rounded shapes and soft transitions
bring softness into your home.



soft

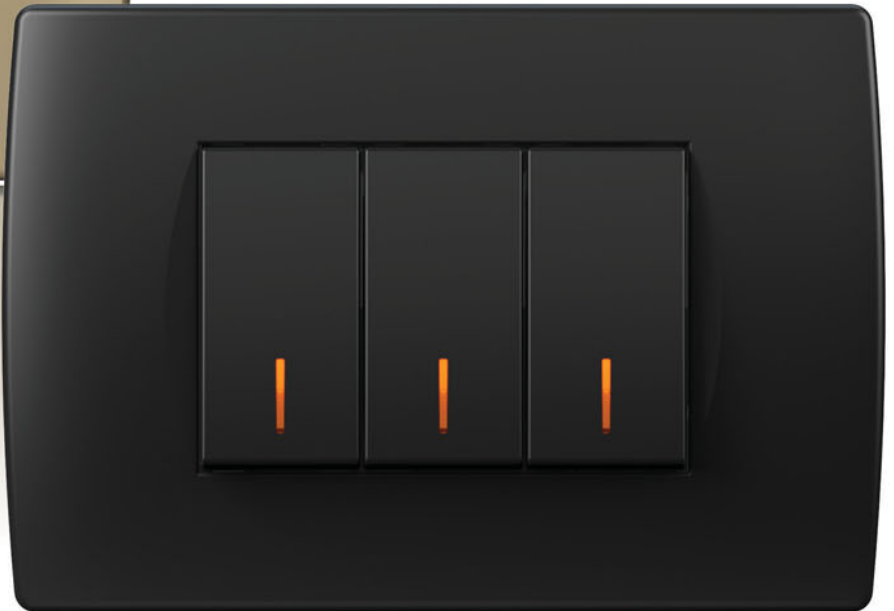



toplina doma a warm home

Popolnost mehke oblike smo nadgradili s subtilnim izborom barv in posebnimi nanosi, ki jih čutite ob dotiku.

Perfectly soft shapes rounded off by a subtle selection of colours and special coatings for a special touch.

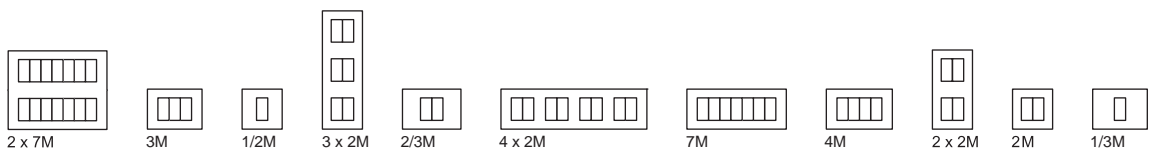

univerzalni zatemnilnik

universal dimmer

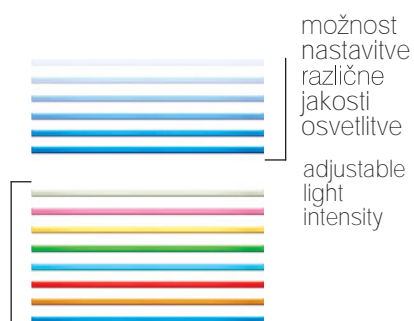
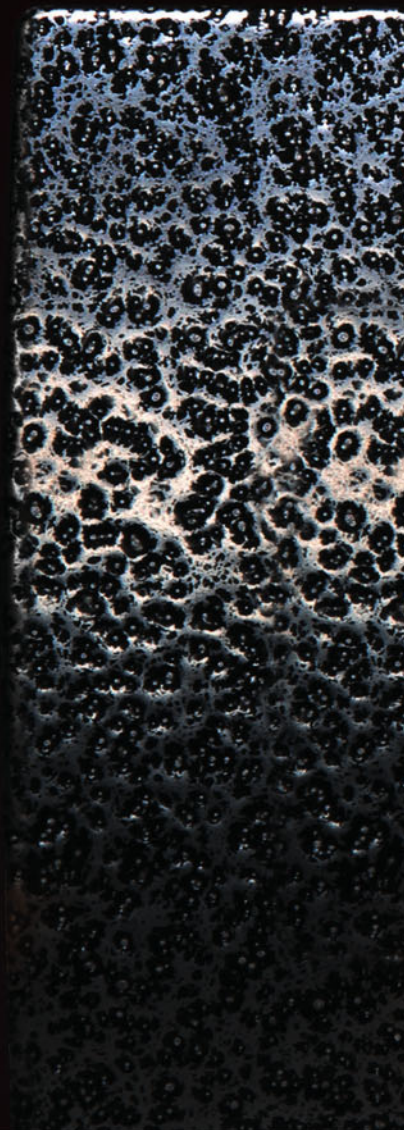

možnost
nastavitve
različne
jakosti
osvetlitve

adjustable
light
intensity

možnost
izbire
različnih
barv
osvetlitve
choosing
illumination
colour

V temi postane Touch nežna, ambientalna lučka, ki označuje mesto stikala in blago razsvetljuje prostor. Izberete lahko eno od osmih različnih barv nežne svetlobe, katerih svetlost lahko kadarkoli poljubno prilagodite svojemu razpoloženju.

In the dark Touch becomes a tender soft ambient light. It marks the spot of a switch and gently illuminates a place. You can choose among eight different colours of tender light and adapt its brightness according to your mood.



svetloba, kot še nikoli light as never seen before

Pridušena svetloba ustvarja ozračje miru, pa tudi čutnosti in romantike. Je zaščitni znak romantičnih lokalov in mirnih poznovečernih ur doma ali v delovnem prostoru. Mehak, podaljšan vklop ne podaljšuje le življenjske dobe sijalke, ampak tudi veliko prijazneje in počasneje zamenja temo s svetlobo. Touch omogoča, da zatemnite svetlobo kjerkoli, ne glede na tip sijalke ali žarnice.

A dimmed light makes peaceful, sensual and romantic atmosphere. It is a trade mark of romantic places and quiet late evening hours spent at home or at work. Switching is soft and extended. It does not only prolong the lamp life expectancy, but also changes darkness into light in a slower and much more pleasant way. Touch enables you to dim the light anywhere, regardless of the type of lamps.





vse na enem mestu

everything in one place

Vaša hiša je postala središče življenja. Množica vseh naprav zahteva številne priključke in vtičnice. Sestavite si svoj multimedijijski center, ki vam nudi možnost priključitve in upravljanja več različnih komponent na enem mestu.

Your house is the centre of your life. The multitude of devices you use requires a number of connectors and sockets. Create your own multimedia centre, one that will allow you to connect and use a multiple number of different components in one place.





inovativen krmilnik temperature

innovative temperature controller

Poskrbite za svoje udobje in s pametnim termostatom upravljajte temperaturo bivalnih in delovnih prostorov v vseh letnih časih. Upravljate lahko naprave gretja in hlajenja z možnostjo ekonomičnega delovanja.

Make yourself comfortable by controlling the temperature in your living and working rooms during all seasons with a smart thermostat. It allows you to control heating and cooling devices and features an eco-function.

udobje prostora

comfort in your room



udobje uporabe
convenience of use



TOUCHLESS-brez dotika

Brezdotično stikalo vam omogoča sodoben način življenja, saj svetila lahko prižigate in ugašate, ne da bi se dotaknili stikala. Ta možnost je zelo uporabna, če imate polne ali umazane roke, saj lahko luč prižgete brez dotika.

The touchless switch allows you to enjoy a modern lifestyle, enabling the turning on and off of your lights, without the need for physical interaction. This option is very useful when you find yourself with your hands full, or dirty, as you can achieve the desired lighting without undue fuss.



sodobna osvetlitev

modern illumination





3D svetilka

3D lamp

Hiter tempo življenja prinaša množico informacij. 3D barvna svetilka je elegantna rešitev za označevanje, usmerjanje in sporočanje. Grafiko izdelamo po vaši želji.

The rapid pace of life means you are constantly being bombarded with a plenty of information. 3D colour lamp provide an elegant solution for information and direction signs. We can make graphics according to your wishes.



ARX – adijo ključi

ARX – say goodbye to keys

ARX ONE vam omogoča varen in udoben vstop v stanovanje, hišo ali poslovni prostor. Potreben je le poteg s prstom in vrata se odklenejo. Deluje kot samostojna enota, za upravljanje ne potrebujete povezave z računalnikom.

The ARX ONE allows you to gain access to your apartment, house or office securely and conveniently. It takes only a swipe of the finger to unlock the door. It functions as an independent unit and requires no computer connection.

povečana varnost
improved security

29



individualnost

individuality



naredite si svojega

make it your own

Bodite drugačni. Zaželite si stikala po vaši meri. Izbirajte med različnimi barvami okvirjev, lahko vam jih okrasimo s poljubnimi grafikami in napisi. Izberite barvo osvetlitve, ki ustreza vašemu ambientu.

Be different. Make a switch according to your taste. You can choose between different frame colours and we can decorate them for you with custom graphics or signs. Choose a illumination colour that suits the ambience of your room.

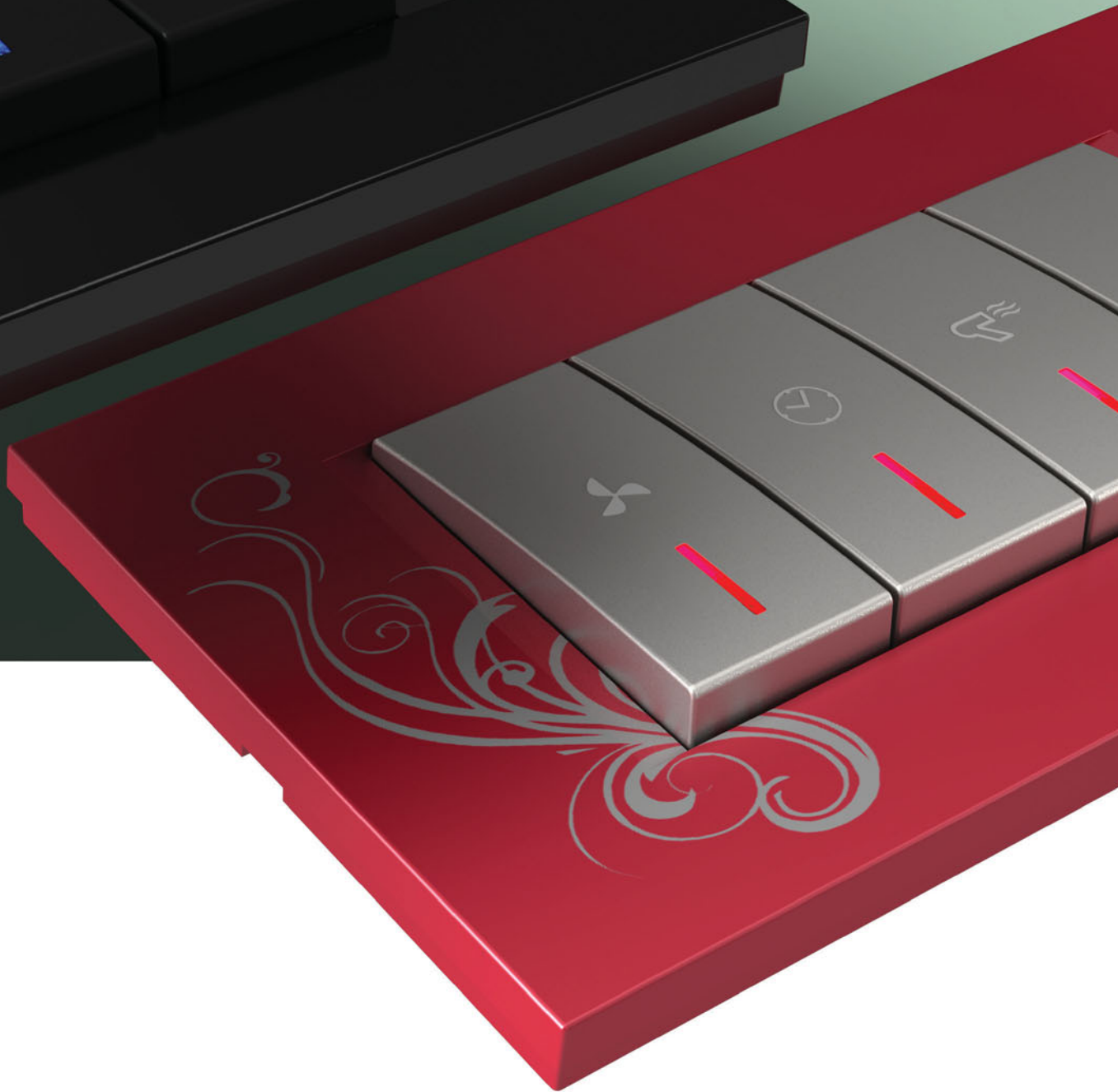
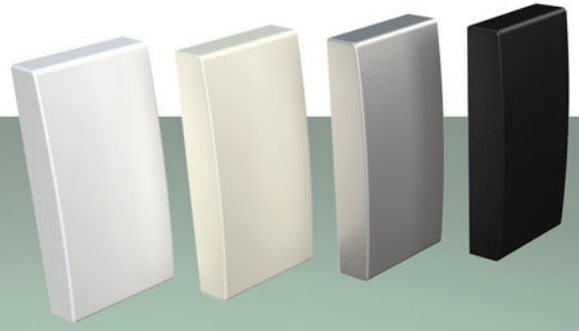

modularnost

modularity

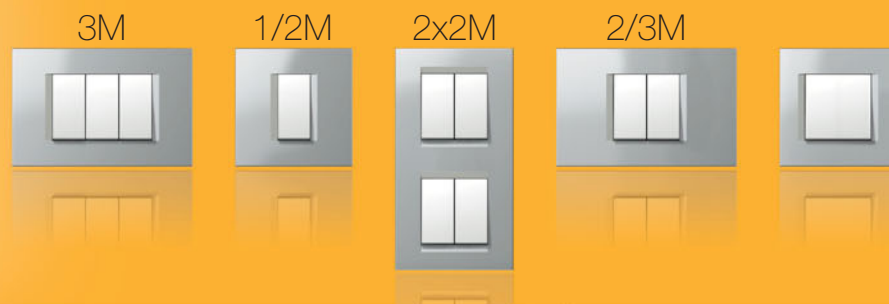

Poskrbeli smo za celovit sistem. V njem najdete vse elemente za poljuben sestav. Osnovni elementi sistema so moduli. Kombinirate jih lahko vodoravno ali navpično.

We have designed a comprehensive system that features a variety of elements, allowing you to create any configuration you wish. The basic elements of the system are modular and can be combined horizontally or vertically.



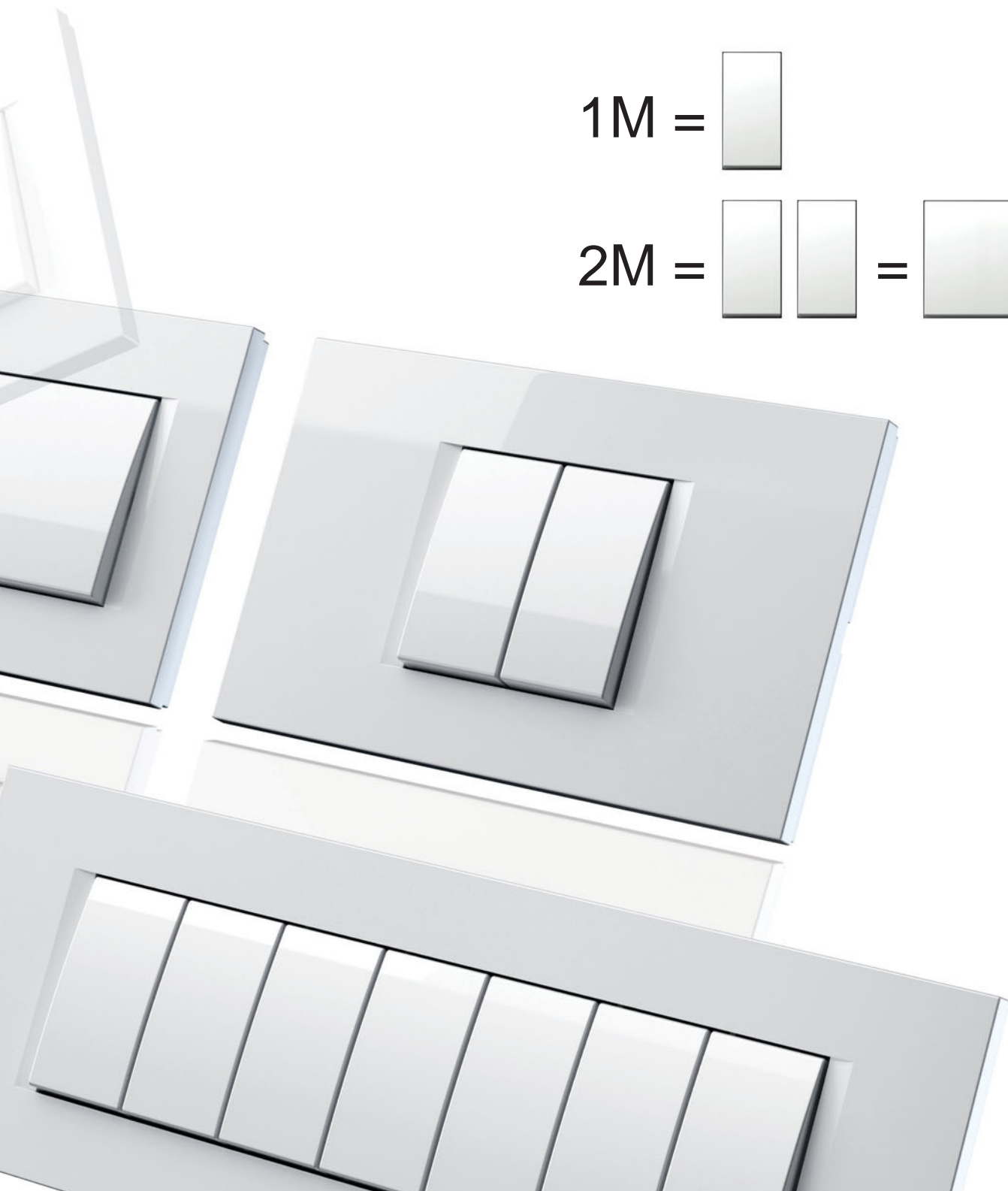
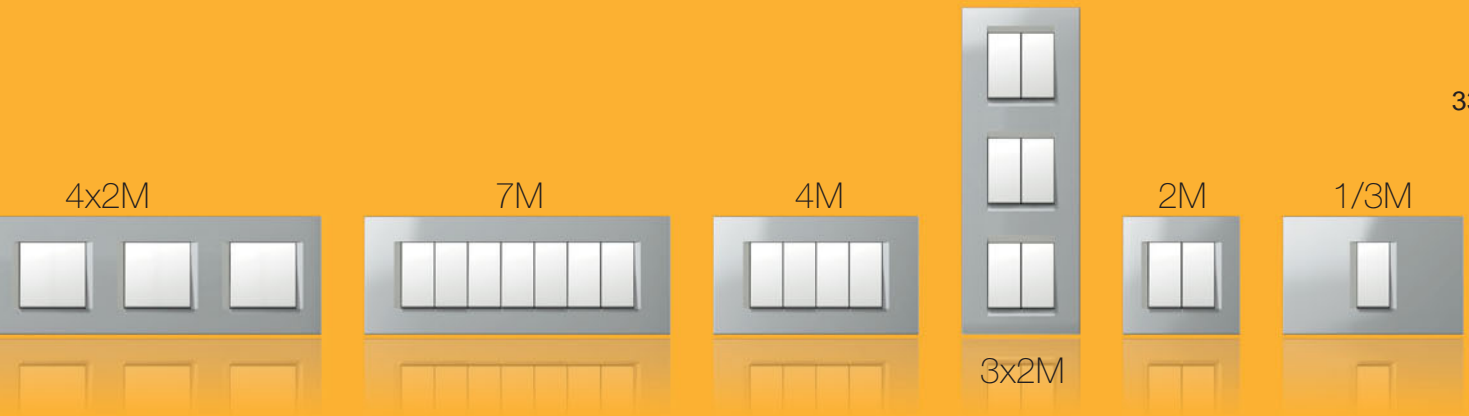

1M = 

2M =  = 

univerzalnost

universality

Sistem odlikuje popoln izbor elementov in enostavna vgradnja.
Set stikal lahko umestite v prostor na veliko načinov,
naj bo doza okrogla ali pravokotna, samostojna ali v nizu.

The system features a comprehensive selection of elements and is easy to install. Switch sets can be positioned in many different ways, regardless of whether the box is round or rectangular, individual or serial.



modulmanager.tem.si



Preizkusite orodje "ModulManager",
ki vam bo pomagal
sestaviti poljubne kombinacije.

Try out the "ModulManager" tool,
which will help you put together
any combination you want.

rešitve za primer 4 stikal

solutions for 4 switches

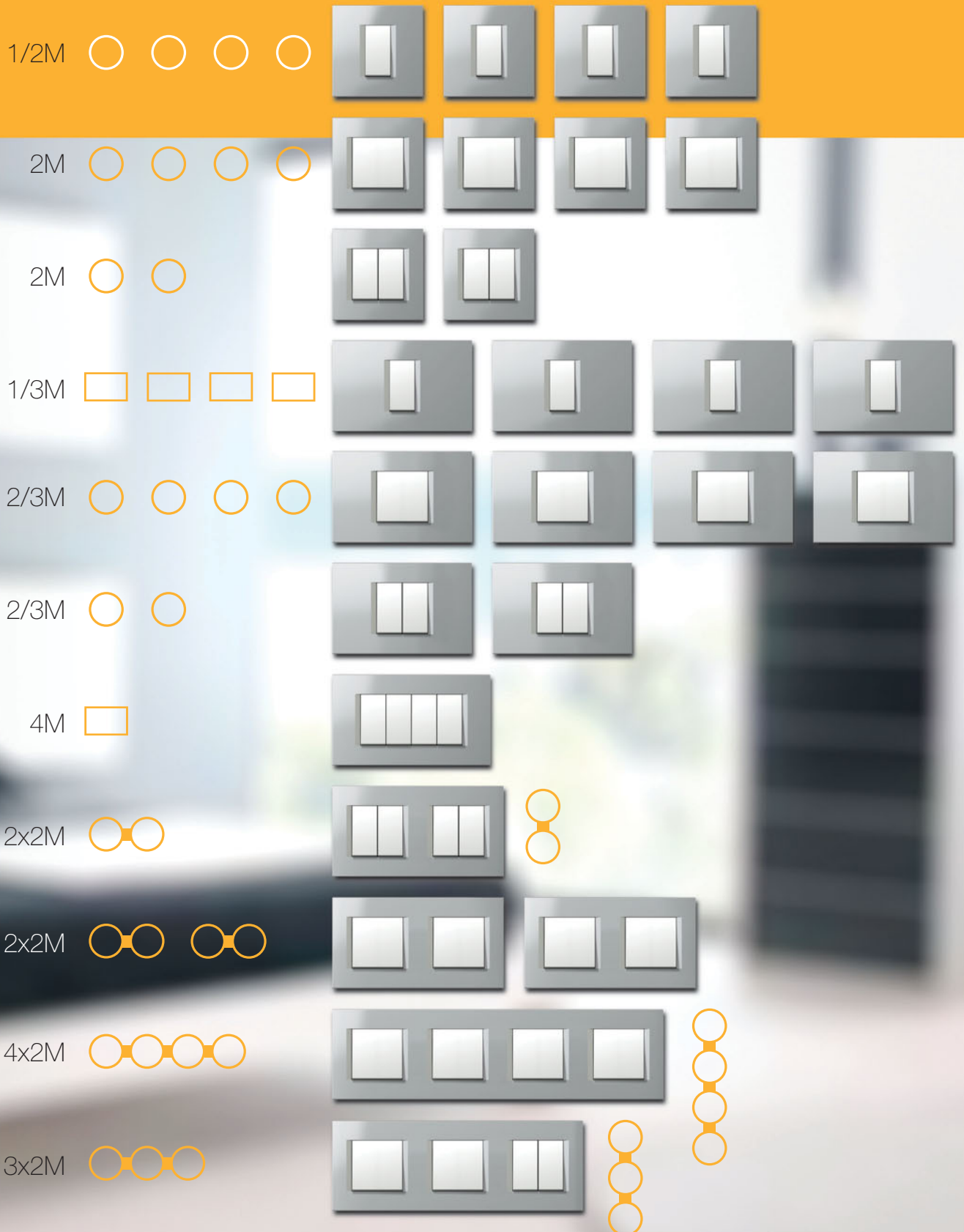

funkcionalnost

functionality

Modul smo razvili za vse, ki znate ceniti premišljeno načrtovan izdelek. Sistem potrebuje manj prostora, saj je v isti okvir možno sestaviti poljubno kombinacijo funkcijskih elementov. Primeren je za novogradnje in adaptacije.

The Modul was developed for those who can appreciate a thoughtfully designed product. The system takes up less space, as any combination of function elements can be fitted inside the same cover plate. It is suitable for new, as well as renovated buildings.



Modul Soft tudi v antibakterijski izvedbi AW.

The Modul Soft is also available in an antibacterial solution AW.

dekorativni okvirji
decorative cover plates

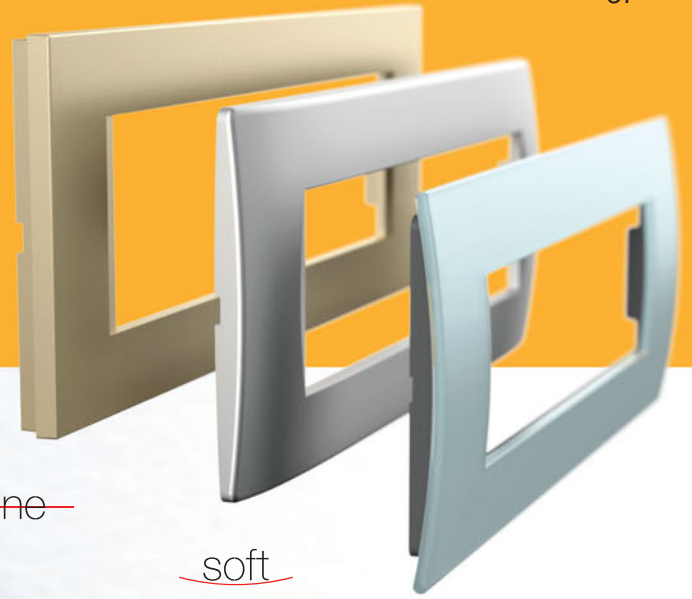

~~line~~

~~soft~~

PURE

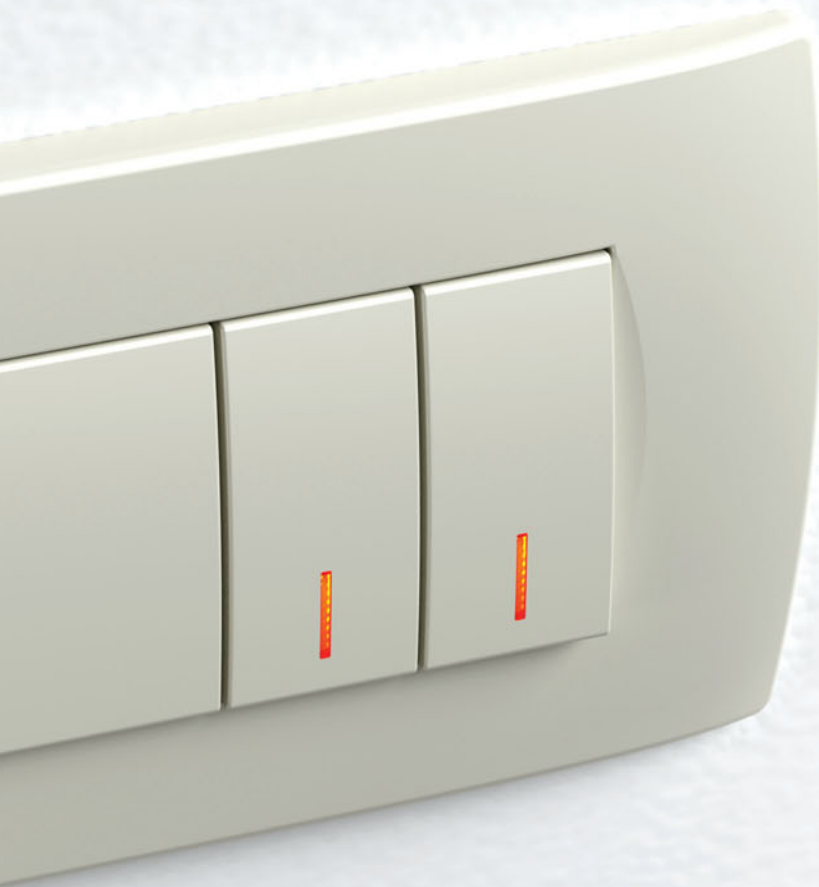

funkcijski elementi
function elements



enostavnost simplicity

Funkcijske elemente enostavno pritrdite v nosilec. Za vas smo razvili rešitev "klik-in, klik-out", ki vam skrajšuje čas montaže. Priključni kontakti so lahko dostopni s sprednje strani.

The function elements are easily fitted inside the mounting frame.
The "klik-in, klik-out" solution we have developed for you will reduce installation time. The connection contacts are easily accessible from the front.

line
soft
PURE

klik-in, klik-out

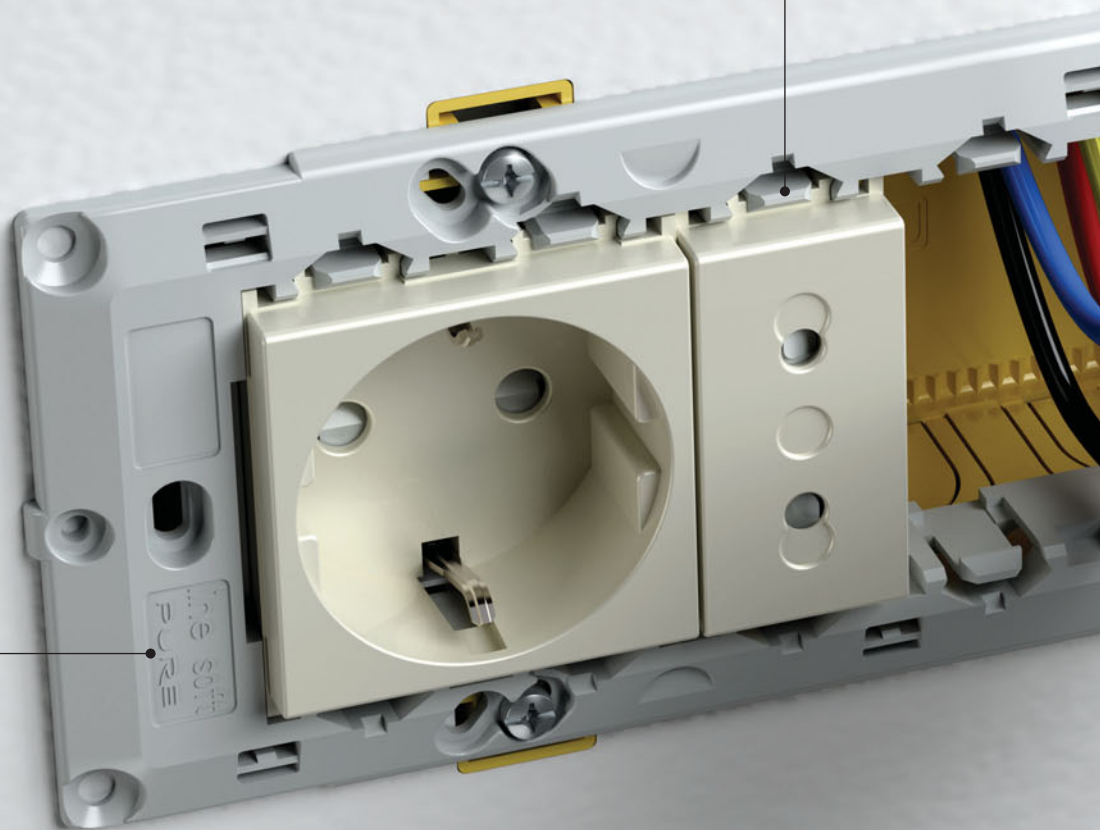

"klik-out" - enostavno in hitro,
brez vijačenja.

"klik-out" - simple and quick,
no screws necessary.

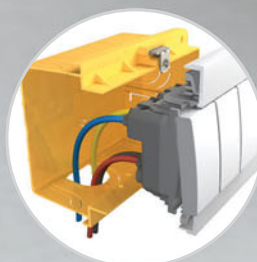

V pravokotnih dozah je več prostora
za priključne vodnike.

Rectangular boxes have more space
for connection wires.

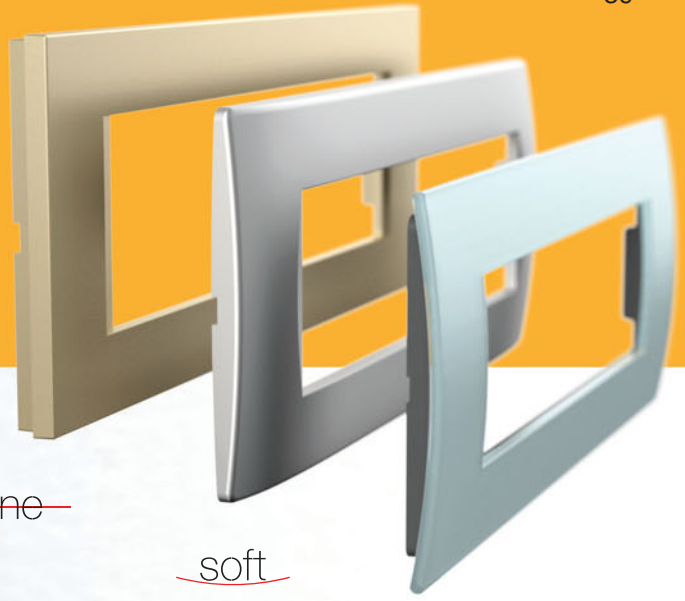
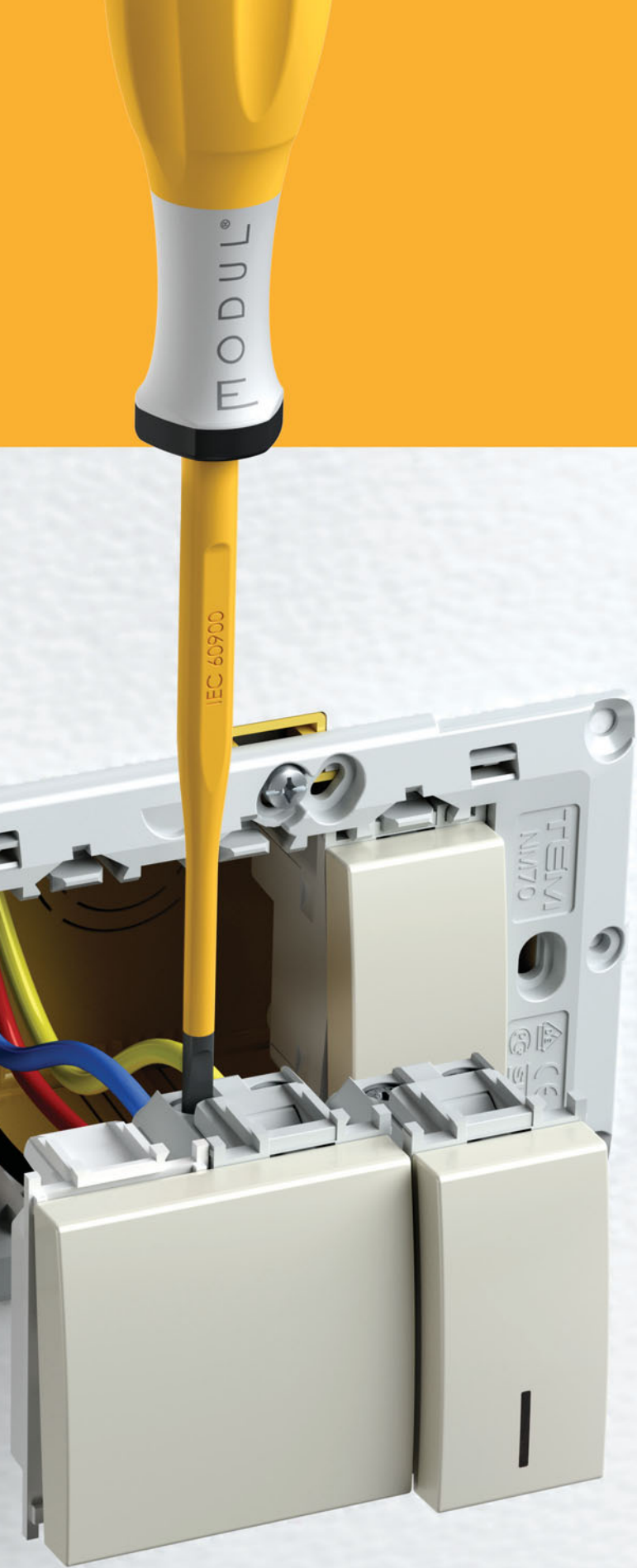

~~line~~

soft

PURE

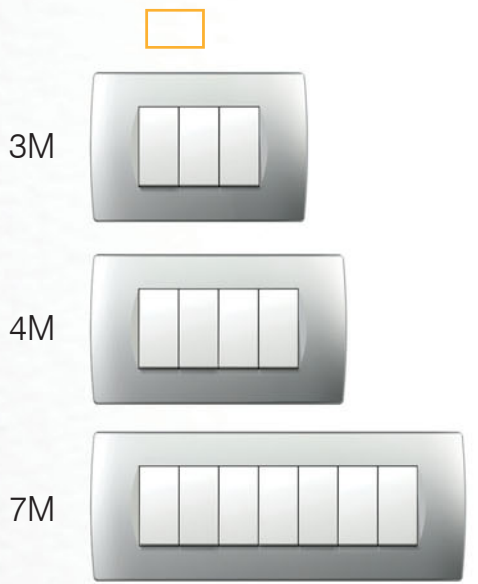

3M

4M

7M

sestavljivost

combinability

Modul vam ponuja veliko možnosti tudi ob uporabi okroglih doz. Kombinirate lahko vodoravno ali navpično, samostojno ali v skupinah. Kovinski nosilec zagotavlja odlično stabilnost tudi pri grobi uporabi in je primeren za vse dekorativne okvirje.

The Modul enables a many possibilities even with round boxes. You can combine them horizontally or vertically, individually or in groups. The metal mounting frame ensures excellent stability even with rough use and is suitable for any decorative cover plates.

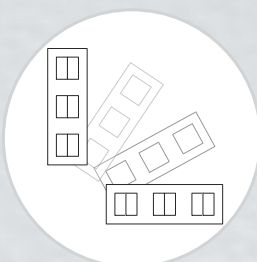
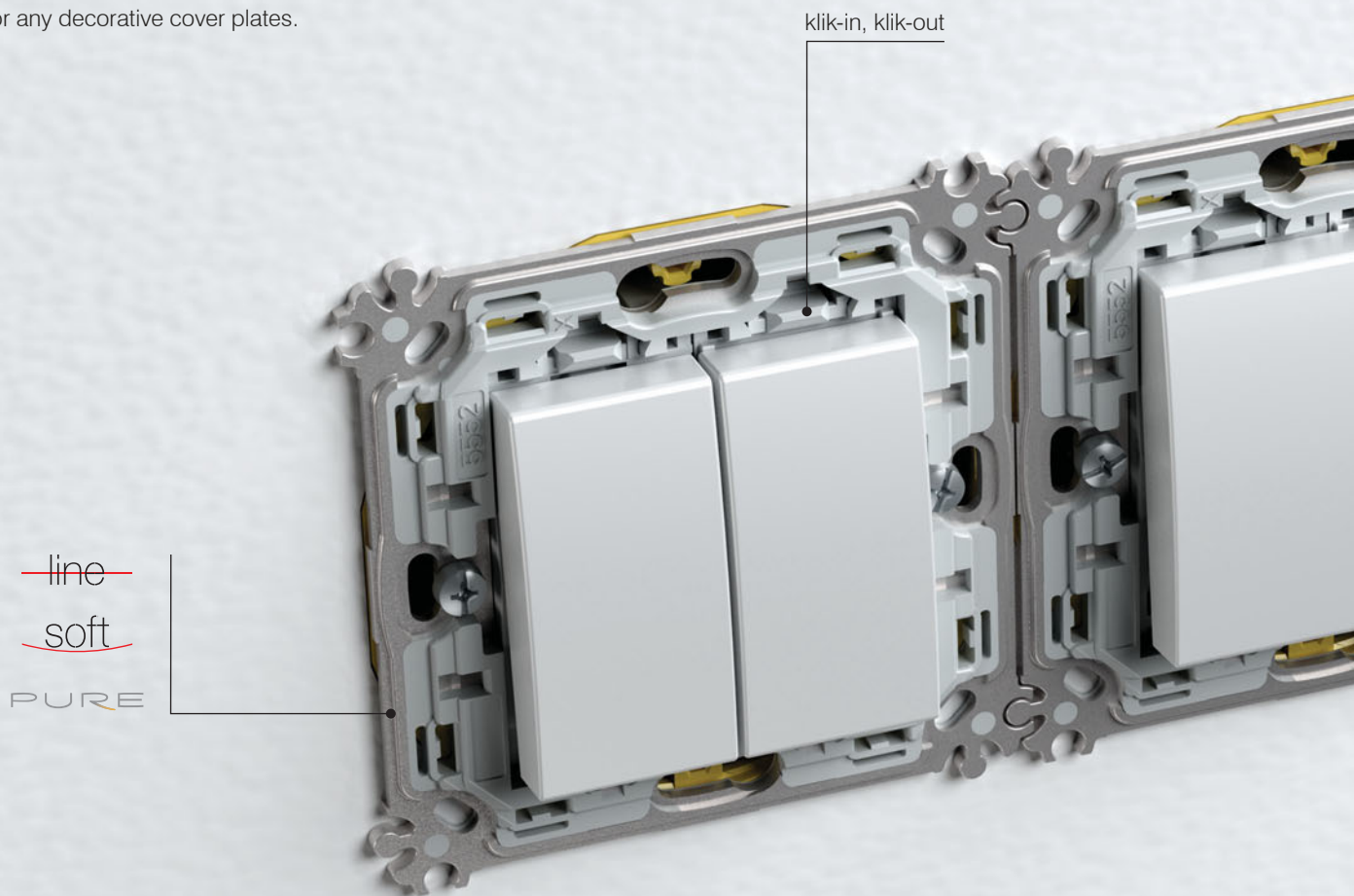

Isti okvir je možno uporabiti vodoravno ali navpično.

The same cover plate can be positioned horizontally or vertically.

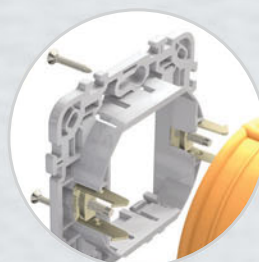

Nosilci se lahko pritrdijo z vijaki ali krempljci.

Mounting frames can be fixed with screws or claws.

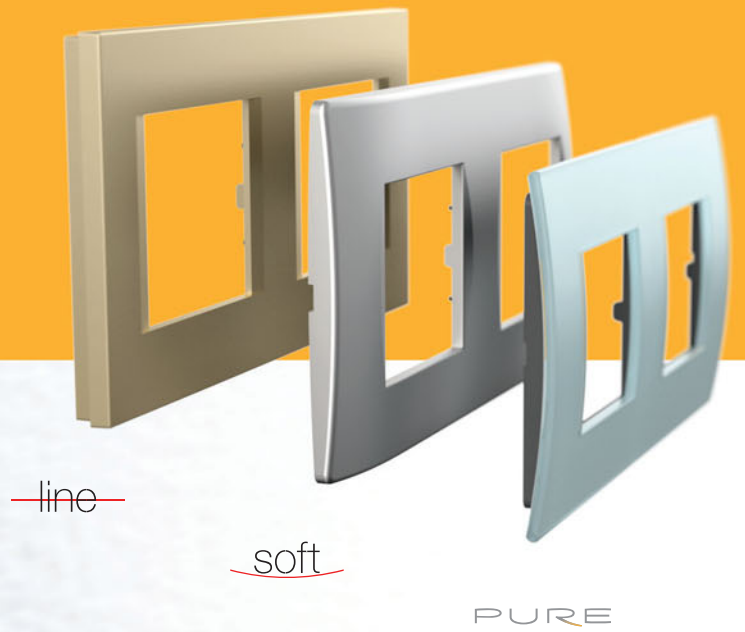

Nosilce velikosti 2M je mogoče s preprostim preklopom povezati v večje skupine.

2M mounting frames are easily joined into groups.

univerzalnost

universality

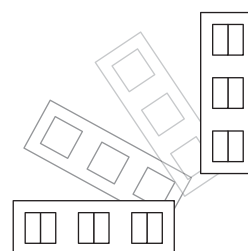
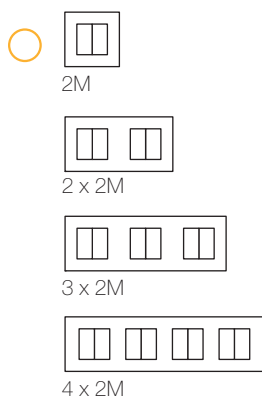
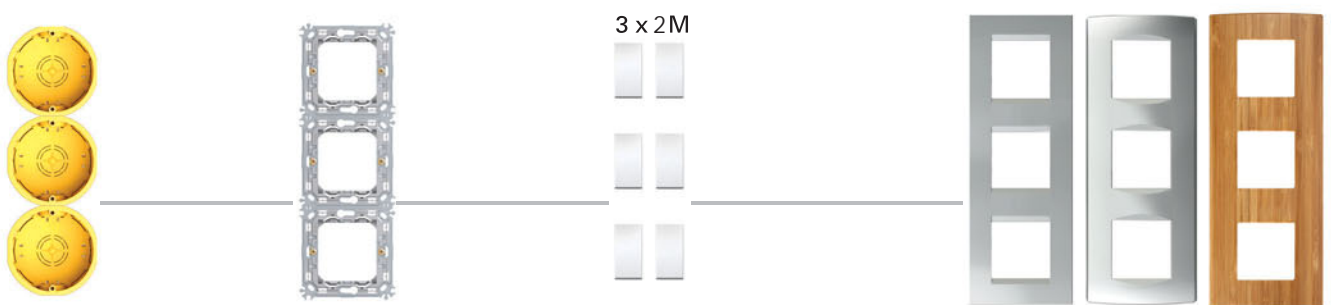
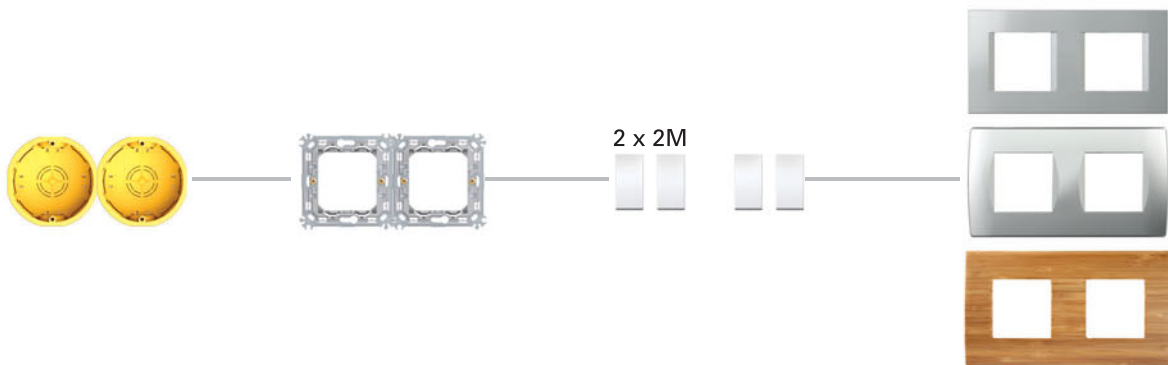
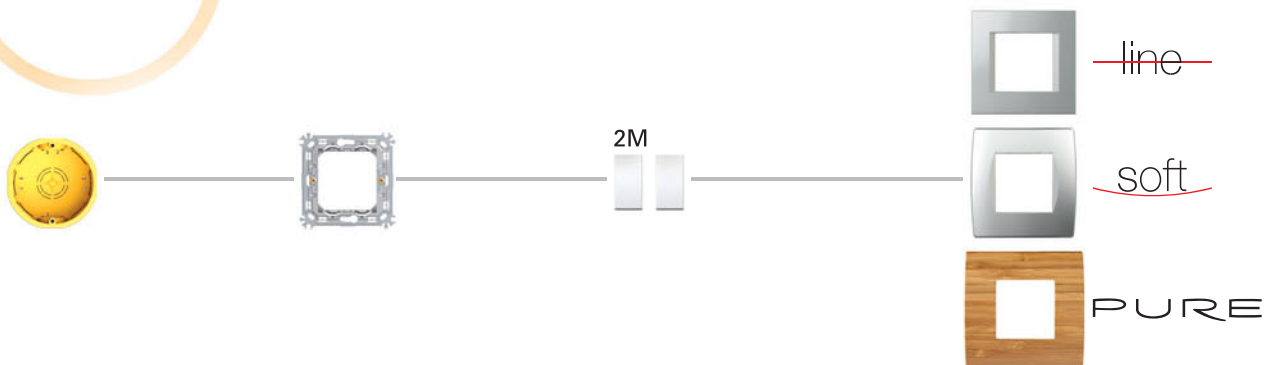

Sistem je univerzalen, primeren za vgradnjo v okrogle in pravokotne doze.

The system is universal and can be fitted in both round and rectangular boxes.

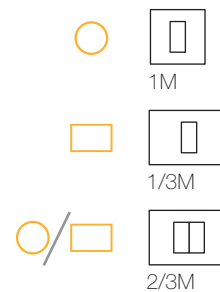
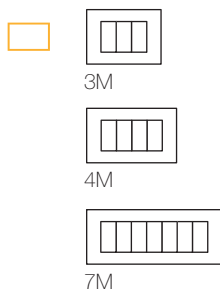
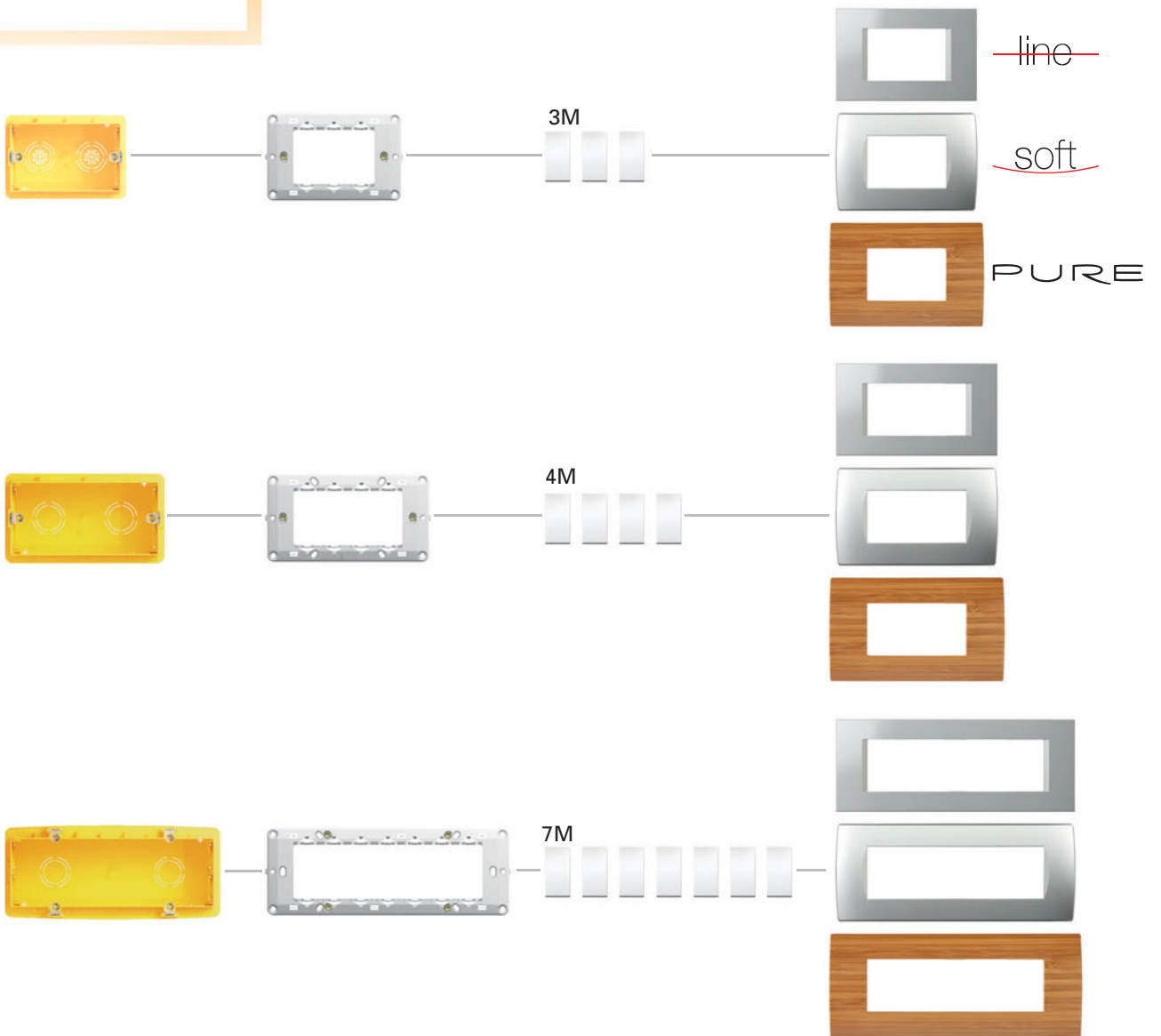

funkcijski elementi

function elements

• stikala / switches



• vstop / entrance

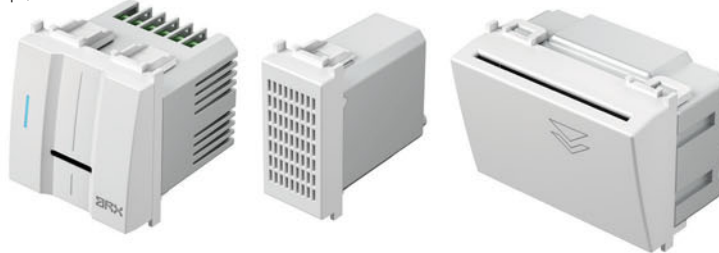

MODUL

• varčevanje z energijo / energy saving



Zanesljiva priključitev vodnikov različnih premerov.

Reliable connection even when different size of wires are used.



Dolga življenska doba stikal in ustreznost sodobnim standardom.

Long-life of switches and adequacy to the international standards.

Poskrbeli smo, da v družini Modul najdete širok nabor funkcijskih elementov. Z njimi lahko načrtujete enostavne ali zahtevne inštalacije.

We have designed a wide selection of function element for the Modul family. You can use them to design both simple and complex installations.



• vtičnice / sockets

• zabava / entertainment

• osvetlitev / illumination



Vse vtičnice imajo vgrajeno varovalo pred dotikom elementov pod napetostjo.
All the sockets are equipped with a safety shutters assuring the protection to live contacts.



Zanesljivost preklopa omogočajo srebrne kontaktne kovice.
The switch is highly reliable via its silver rivets contacts.

edinstvena širina uporabnosti

unique range of usability

Modul Soft AW
antibakterijska izvedba /
antibacterial solution



MODUL

CUBO IP20

nadometna ohišja
surface mounted boxes



CUBO IP55

nadometna ohišja
surface mounted boxes



IP44

podomet
flush mounted



Opremljate dom, pisarno ali delavnico?
Modul lahko uporabite tako v bivalnih kot delovnih prostorih,
zasebnih in javnih zgradbah. Edinstven je v tem, da lahko stikala
in vtičnice vgradite tam, kjer jih potrebujete.

Are you furnishing your home, office or workshop? The Modul is suitable
for living as well as working spaces and both private and public buildings.
It is unique in that the switches and sockets can be fitted wherever they are
needed.

D

opeka
brick



H

votla stena
hollow wall



B

beton
concrete

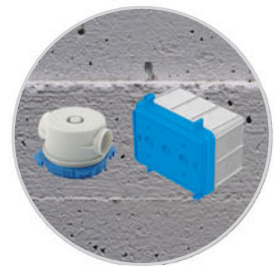

funkcijski elementi /
function elements

stikala / switches
vtičnice / sockets
komunikacije / communications
senzorji / sensors
regulatorji / regulators
osvetlitve / illuminations

MA

parapetni kanali
trunking systems



MO

razdelilne omarice
distribution boards



MT

talne doze
floor boxes



podometne rešitve

flush mounted solutions

opeka / brick

Modul lahko vgradite v katerokoli vrsto stene, naj bo klasična, suho montažna ali betonska. Vgradnja je enostavna, ponuja vam možnosti sestavljanja pravokotnih ali okroglih doz na ustrezne razdalje. Uporabljeni materiali so testirani po visokih standardih.

The Modul is suitable for all wall types and can be used in conventional, hollow wall or concrete constructions. It is easy to install and enables you to combine rectangular or round boxes at the proper distances. The materials used are compliant with high standards.

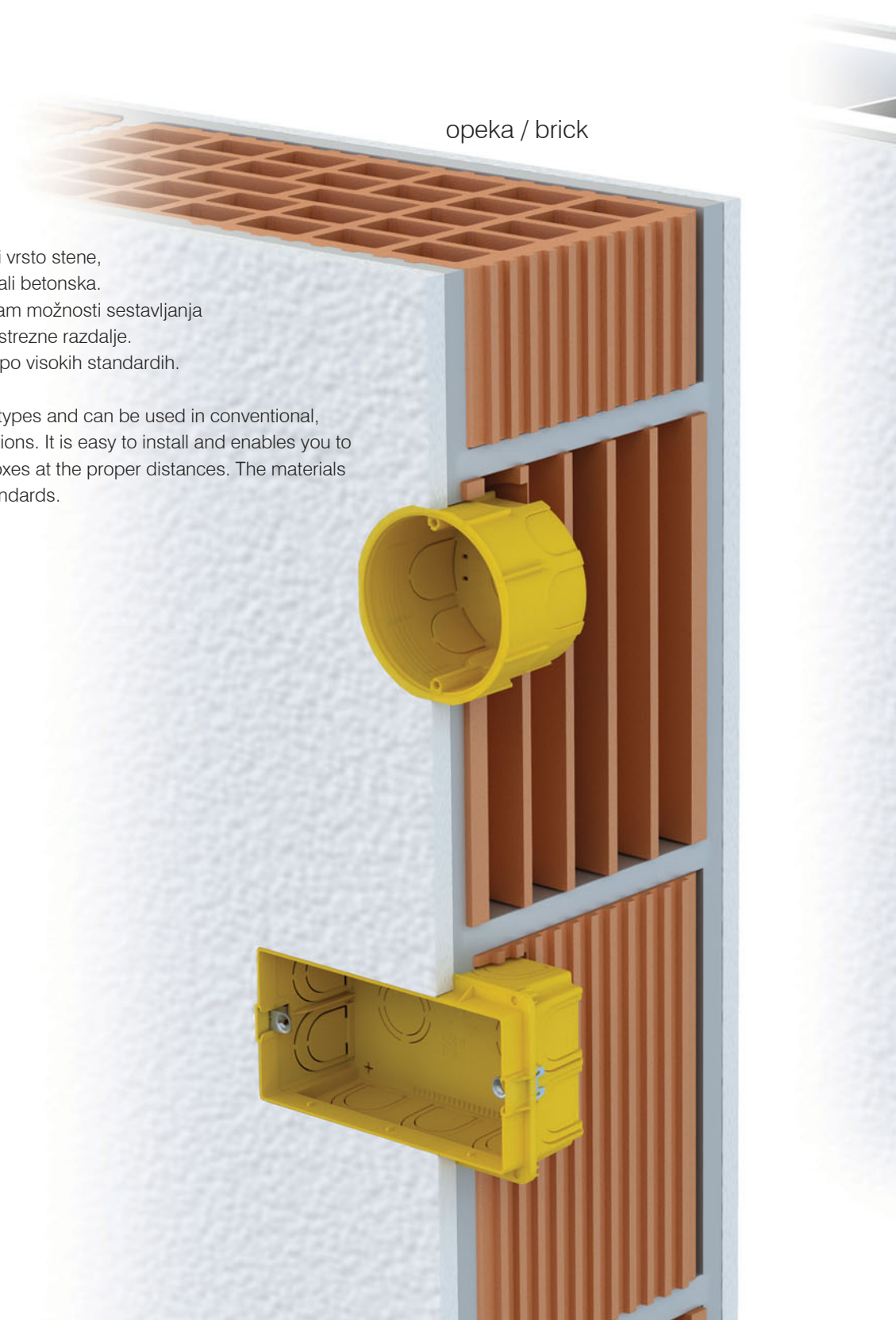



druge rešitve

other solutions

IP44
podomet
flush mounted



CUBO IP20
nadometna ohišja
surface mounted boxes

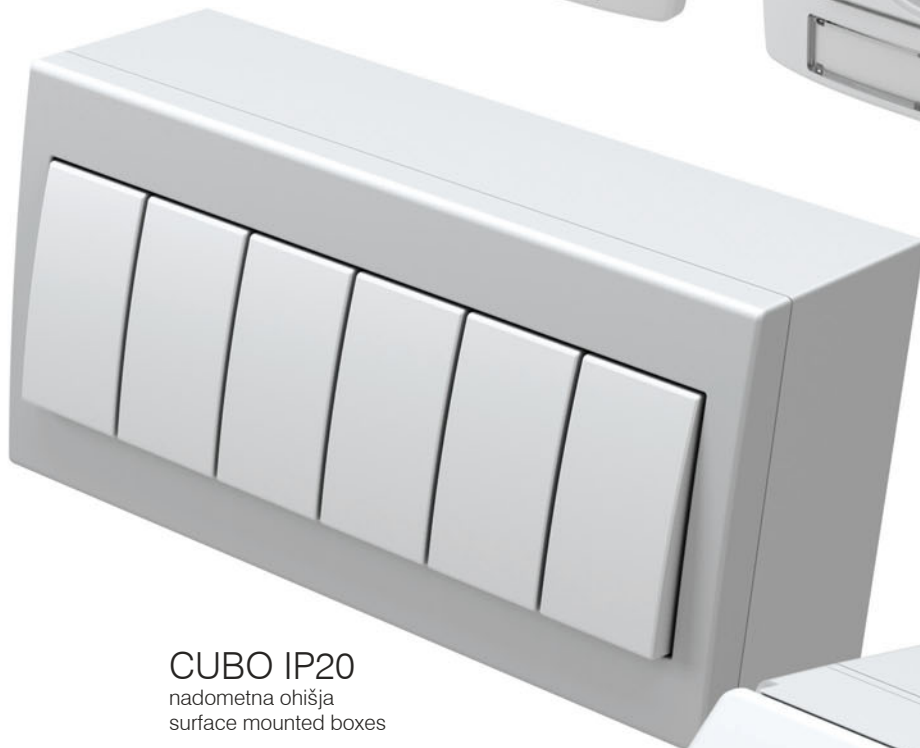

CUBO IP55
nadometna ohišja
surface mounted boxes



Potrebujete stikalo ali vtičnico v podometni, nadometni ali talni izvedbi?
Modul ponuja različne rešitve vgradnje, v različnih IP zaščitah, v
parapetne kanale, razdelilne omarice ali talne doze. Izbira je vaša.

Do you need switch or socket in flush, surface or floor solution?
The Modul provides different mounting solutions with different IP
protections, for trunking systems, distribution boards or floor boxes.
The choice is yours.



MA

parapetni kanali
trunking systems

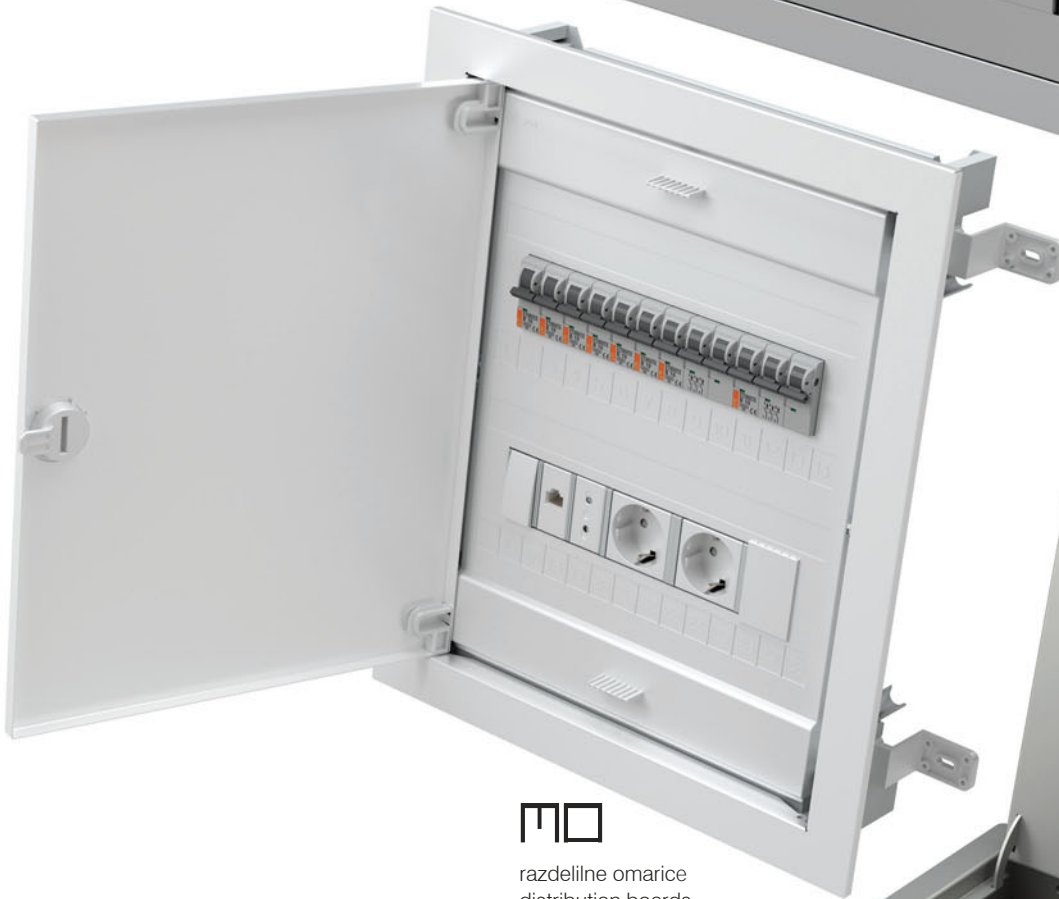

MO

razdelilne omarice
distribution boards

MT

talne doze
floor boxes



tehnični katalog

technical catalogue





MODUL

funkcijski elementi
function elements



54

dizajn
design

PURE
~~line~~
soft



102

doze
boxes



122

distribucija
distribution



144

TEM



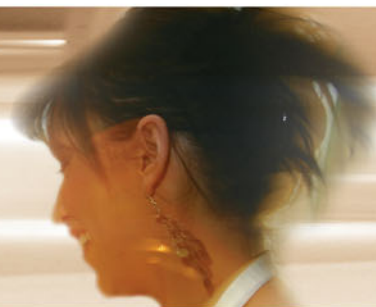

FUNKCIJSKI ELEMENTI FUNCTION ELEMENTS

STIKALA SM
SWITCHES SM



56

TIPKE TM
BUTTONS TM



61

INDIKACIJA IA
ILLUMINATION IA



64

VTIČNICE VM
SOCKETS VM



66

KOMUNIKACIJE KM
COMMUNICATIONS KM



70

KOMUNIKACIJSKI PRIBOR KA
COMMUNICATION ACCESSORIES KA



76

ELEKTRONIKA EM
ELECTRONICS EM



78

SETI CM
SETS CM



94

ANTIBAKTERIJSKI PROGRAM AW
ANTIBACTERIAL PROGRAM AW



98

OBLIKA DESIGN

OKVIRJI PURE OP
COVER PLATES PURE OP



102

OKVIRJI LINE OL
COVER PLATES LINE OL



106

OKVIRJI SOFT OS
COVER PLATES SOFT OS



110

NOSILCI NM
MOUNTING FRAMES NM



118

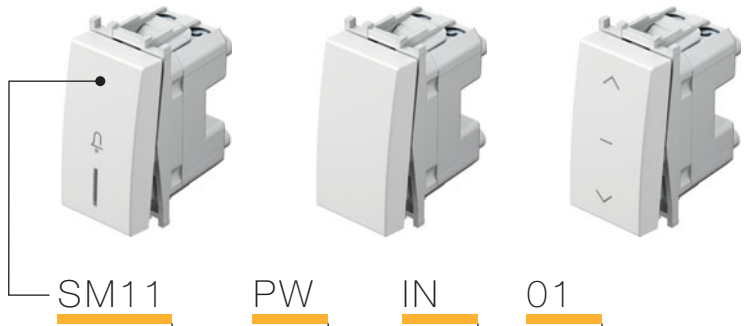

tip type	naziv description	tehnični opis technical data	velikost size	barva colour	opcijski opis 1 optional data 1	opcijski opis 2 optional data 2
SM10	STIKALO ENOPOLNO SWITCH 1WAY	16AX 250V~	1M	<input type="checkbox"/> PW bela-sijaj polar white	<input type="checkbox"/> NT nevtral neutral	01
SM11	TIPKALO ENOPOLNO PUSH BUTTON 1WAY	16A 250V~	1M	<input checked="" type="checkbox"/> SB črna-mat soft touch black	<input type="checkbox"/> IN indikator indicator	02
SM12	STIKALO ENOPOLNO SWITCH 1WAY	20A 250V~	1M	<input type="checkbox"/> ES srebrna-mat elox silver		03
.	.	.	.	<input type="checkbox"/> IW bež-sijaj ivory white		.

STIKALO ENOPOLNO 16AX 250V~ 1M



SM10

- stikalo brez tipke
- 16AX 250V~, tip SM10
- ustreza EN 60669-1
- vijačna pritrditev vodnikov 1.5-2.5mm²

SWITCH 1WAY 16AX 250V~ 1M

- switch without button
- 16AX 250V~, type SM10
- in accordance with EN 60669-1
- screw contacts 1.5-2.5mm²



TIPKALO ENOPOLNO 16A 250V~ 1M



SM11

- tipkalo brez tipke
- 16A 250V~, tip SM11
- ustreza EN 60669-1
- vijačna pritrditev vodnikov 1.5-2.5mm²

PUSH BUTTON 1WAY 16A 250V~ 1M

- push button without button
- 16A 250V~, type SM11
- in accordance with EN 60669-1
- screw contacts 1.5-2.5mm²

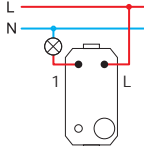

STIKALO ENOPOLNO 20A 250V~ 1M



SM12

- stikalo brez tipke
- 20A 250V~, tip SM12
- ustreza EN 60669-1
- vijačna pritrditev vodnikov 1.5-2.5mm²

SWITCH 1WAY 20A 250V~ 1M

- switch without button
- 20A 250V~, type SM12
- in accordance with EN 60669-1
- screw contacts 1.5-2.5mm²

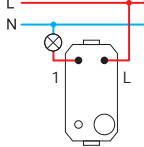

STIKALO DVOPOLNO 16AX 250V~ 1M



SM20

- stikalo brez tipke
- 16AX 250V~, tip SM20
- ustreza EN 60669-1
- vijačna pritrditev vodnikov 1.5-2.5mm²
- samo v kombinaciji s tipko TM15

SWITCH 2POLE 16AX 250V~ 1M

- switch without button
- 16AX 250V~, type SM20
- in accordance with EN 60669-1
- screw contacts 1.5-2.5mm²
- only in combination with button TM15

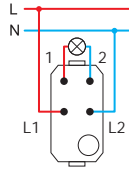

STIKALO ŽALUZIJSKO 1-0-2 16AX 250V~ 1M



SM40

- stikalo brez tipke
- 16AX 250V~, tip SM40
- ustreza EN 60669-1
- vijačna pritrditev vodnikov 1.5-2.5mm²



SWITCH SHUTTERS 1-0-2 16AX 250V~ 1M

- switch without button
- 16AX 250V~, type SM40
- in accordance with EN 60669-1
- screw contacts 1.5-2.5mm²

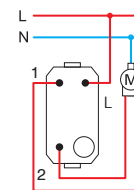

TIPKALO ŽALUZIJSKO 1-0-2 16A 250V~ 1M



SM41

- tipkalo brez tipke
- 16A 250V~, tip SM41
- ustreza EN 60669-1
- vijačna pritrditev vodnikov 1.5-2.5mm²

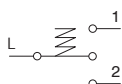

PUSH BUTTON SHUTTERS 1-0-2 16A 250V~ 1M

- push button without button
- 16A 250V~, type SM41
- in accordance with EN 60669-1
- screw contacts 1.5-2.5mm²

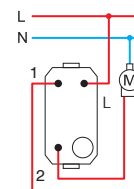

STIKALO MENJALNO 16AX 250V~ 1M



SM60

- stikalo brez tipke
- 16AX 250V~, tip SM60
- ustreza EN 60669-1
- vijačna pritrditev vodnikov 1.5-2.5mm²

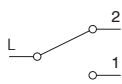

SWITCH 2WAY 16AX 250V~ 1M

- switch without button
- 16AX 250V~, type SM60
- in accordance with EN 60669-1
- screw contacts 1.5-2.5mm²

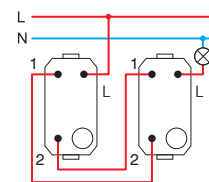

TIPKALO MENJALNO 16A 250V~ 1M



SM61

- tipkalo brez tipke
- 16A 250V~, tip SM61
- ustreza EN 60669-1
- vijačna pritrditev vodnikov 1.5-2.5mm²

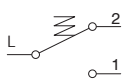

PUSH BUTTON 2WAY 16A 250V~ 1M

- push button without button
- 16A 250V~, type SM61
- in accordance with EN 60669-1
- screw contacts 1.5-2.5mm²

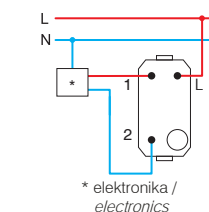

* elektronika / electronics

STIKALO KRIŽNO 16AX 250V~ 1M



SM70

- stikalo brez tipke
- 16AX 250V~, tip SM70
- ustreza EN 60669-1
- vijačna pritrditev vodnikov 1.5-2.5mm²



SWITCH INTERMEDIATE 16AX 250V~ 1M

- switch without button
- 16AX 250V~, type SM70
- in accordance with EN 60669-1
- screw contacts 1.5-2.5mm²

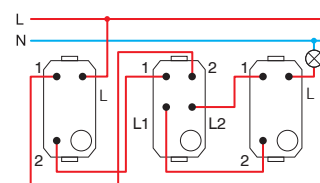

1M = 22,5 x 45
2M = 45 x 45

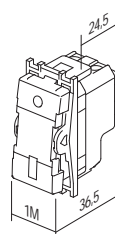
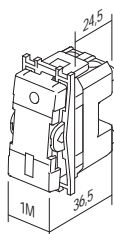



□ PW bela-sijaj
polar white



■ SB črna-mat
soft touch black



□ ES srebrna-mat
elox silver



□ IW bež-sijaj
ivory white

STIKALO ENOPOLNO 16AX 250V~ 1M



- SM10PW
- SM10SB
- SM10ES
- SM10IW

- 16AX 250V~, tip SM10
- ustreza EN 60669-1
- vijačna pritrditev vodnikov 1.5-2.5 mm²
- zamenljiva tipka

SWITCH 1WAY 16AX 250V~ 1M
- 16AX 250V~, type SM10
- in accordance with EN 60669-1
- screw contacts 1.5-2.5 mm²
- replaceable button



STIKALO ENOPOLNO 16AX 250V~ 1M __ IN



- SM10PWIN
- SM10SBIN
- SM10ESIN
- SM10IWIN

- IN indikator
- 16AX 250V~, tip SM10
- ustreza EN 60669-1
- vijačna pritrditev vodnikov 1.5-2.5 mm²
- tiivka ni priložena
- zamenljiva tipka

SWITCH 1WAY 16AX 250V~ 1M __ IN
- IN indicator
- 16AX 250V~, type SM10
- in accordance with EN 60669-1
- screw contacts 1.5-2.5 mm²
- lamp is not included
- replaceable button



TIPKALO ENOPOLNO 16A 250V~ 1M

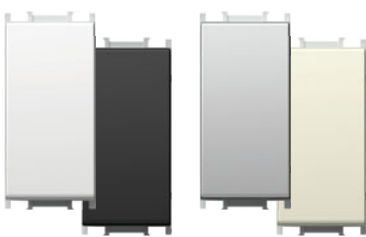

- SM11PW
- SM11SB
- SM11ES
- SM11IW

- 16A 250V~, tip SM11
- ustreza EN 60669-1
- vijačna pritrditev vodnikov 1.5-2.5 mm²
- zamenljiva tipka

PUSH BUTTON 1WAY 16A 250V~ 1M
- 16A 250V~, type SM11
- in accordance with EN 60669-1
- screw contacts 1.5-2.5 mm²
- replaceable button



TIPKALO ENOPOLNO 16A 250V~ 1M __ IN 01



- SM11PWIN01
- SM11SBIN01
- SM11ESIN01
- SM11IWIN01

- IN 01 indikator zvonec
- 16A 250V~, tip SM11
- ustreza EN 60669-1
- vijačna pritrditev vodnikov 1.5-2.5 mm²
- tiivka ni priložena
- zamenljiva tipka

PUSH BUTTON 1WAY 16A 250V~ 1M __ IN 01
- IN 01 indicator bell
- 16A 250V~, type SM11
- in accordance with EN 60669-1
- screw contacts 1.5-2.5 mm²
- lamp is not included
- replaceable button



TIPKALO ENOPOLNO 16A 250V~ 1M __ IN 02



- SM11PWIN02
- SM11SBIN02
- SM11ESIN02
- SM11IWIN02

- IN 02 indikator luč
- 16A 250V~, tip SM11
- ustreza EN 60669-1
- vijačna pritrditev vodnikov 1.5-2.5 mm²
- tiivka ni priložena
- zamenljiva tipka

PUSH BUTTON 1WAY 16A 250V~ 1M __ IN 02

- IN 02 indicator light
- 16A 250V~, type SM11
- in accordance with EN 60669-1
- screw contacts 1.5-2.5 mm²
- lamp is not included
- replaceable button



STIKALO DVOPOLNO 16AX 250V~ 1M __ NT 03



- SM20PWNT03
- SM20SBNT03
- SM20ESNT03
- SM20IWNT03

- NT 03 nevtral 0-1
- 16AX 250V~, tip SM20
- ustreza EN 60669-1
- vijačna pritrditev vodnikov 1.5-2.5 mm²
- zamenljiva tipka

SWITCH 2POLE 16AX 250V~ 1M __ NT 03

- NT 03 neutral 0-1
- 16AX 250V~, type SM20
- in accordance with EN 60669-1
- screw contacts 1.5-2.5 mm²
- replaceable button



STIKALO DVOPOLNO 16AX 250V~ 1M __ IN



- SM20PWIN
- SM20SBIN
- SM20ESIN
- SM20IWIN

- IN indikator
- 16AX 250V~, tip SM20
- ustreza EN 60669-1
- vijačna pritrditev vodnikov 1.5-2.5 mm²
- tiivka ni priložena
- zamenljiva tipka

SWITCH 2POLE 16AX 250V~ 1M __ IN

- IN indicator
- 16AX 250V~, type SM20
- in accordance with EN 60669-1
- screw contacts 1.5-2.5 mm²
- lamp is not included
- replaceable button



STIKALO ŽALUZIJSKO 1-0-2 16AX 250V~ 1M __ NT 10



- SM40PWNT10
- SM40SBNT10
- SM40ESNT10
- SM40IWNT10

- NT 10 nevtral 1-0-2
- 16AX 250V~, tip SM40
- ustreza EN 60669-1
- vijačna pritrditev vodnikov 1.5-2.5mm²
- zamenljiva tipka

SWITCH SHUTTERS 1-0-2 16AX 250V~ 1M __ NT 10

- NT 10 neutral 1-0-2
- 16AX 250V~, type SM40
- in accordance with EN 60669-1
- screw contacts 1.5-2.5mm²
- replaceable button



TIPKALO ŽALUZIJSKO 1-0-2 16A 250V~ 1M __ NT 10



- SM41PWNT10
- SM41SBNT10
- SM41ESNT10
- SM41IWNT10

- NT 10 nevtral 1-0-2
- 16A 250V~, tip SM41
- ustreza EN 60669-1
- vijačna pritrditev vodnikov 1.5-2.5mm²
- zamenljiva tipka

PUSH BUTTON SHUTTERS 1-0-2 16A 250V~ 1M __ NT 10

- NT 10 neutral 1-0-2
- 16A 250V~, type SM41
- in accordance with EN 60669-1
- screw contacts 1.5-2.5mm²
- replaceable button



STIKALO MENJALNO 16AX 250V~ 1M



- SM60PW
- SM60SB
- SM60ES
- SM60IW

- 16AX 250V~, tip SM60
- ustreza EN 60669-1
- vijačna pritrditev vodnikov 1.5-2.5 mm²
- zamenljiva tipka

SWITCH 2WAY 16AX 250V~ 1M

- 16AX 250V~, type SM60
- in accordance with EN 60669-1
- screw contacts 1.5-2.5 mm²
- replaceable button



TIPKALO MENJALNO 16A 250V~ 1M

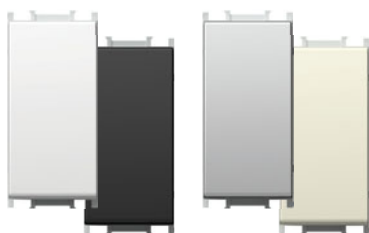

- SM61PW
- SM61SB
- SM61ES
- SM61IW

- 16A 250V~, tip SM61
- ustreza EN 60669-1
- vijačna pritrditev vodnikov 1.5-2.5 mm²
- zamenljiva tipka

PUSH BUTTON 2WAY 16A 250V~ 1M

- 16A 250V~, type SM61
- in accordance with EN 60669-1
- screw contacts 1.5-2.5 mm²
- replaceable button



TIPKALO MENJALNO Z VRVICO 16A 250V~ 1M __ CD



- SM62PWCD
- SM62SBCD
- SM62ESCD
- SM62IWCD

- CD indikator+vrvica
- vrvica dolžine 1.5m
- 16A 250V~, tip SM62
- ustreza EN 60669-1
- vijačna pritrditev vodnikov 1.5-2.5mm²

PUSH BUTTON 2WAY WITH CORD 16A 250V~ 1M __ CD

- CD indicator+cord
- cord lenght 1.5m
- 16A 250V~, type SM62
- in accordance with EN 60669-1
- screw contacts 1.5-2.5mm²



STIKALO KRIŽNO 16AX 250V~ 1M

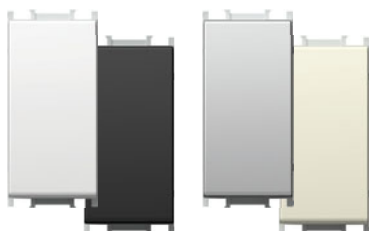

- SM70PW
- SM70SB
- SM70ES
- SM70IW

- 16AX 250V~, tip SM70
- ustreza EN 60669-1
- vijačna pritrditev vodnikov 1.5-2.5 mm²
- zamenljiva tipka

SWITCH INTERMEDIATE 16AX 250V~ 1M

- 16AX 250V~, type SM70
- in accordance with EN 60669-1
- screw contacts 1.5-2.5 mm²
- replaceable button



1M = 22,5 x 45
2M = 45 x 45

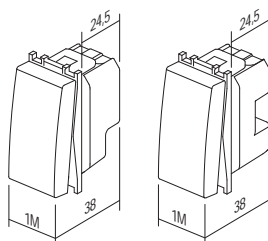

B U T T O N S T M

tip <i>type</i>	naziv <i>description</i>	velikost <i>size</i>	barva <i>colour</i>	opcijski opis 1 <i>optional data 1</i>	opcijski opis 2 <i>optional data 2</i>
TM11	TIPKA <i>BUTTON</i>	1M	<input type="checkbox"/> PW bela-sijaj <i>polar white</i> <input type="checkbox"/> SB črna-mat <i>soft touch black</i> <input type="checkbox"/> ES srebrna-mat <i>elox silver</i> <input type="checkbox"/> IW bež-sijaj <i>ivory white</i>	<input type="checkbox"/> NT nevtral <i>neutral</i> <input type="checkbox"/> IN indikator <i>indicator</i>	01 02 03 . . .
TM12	TIPKA <i>BUTTON</i>	2M			
TM21	POLNILO <i>BLANK</i>	1M			
.
.

TIPKA 1M

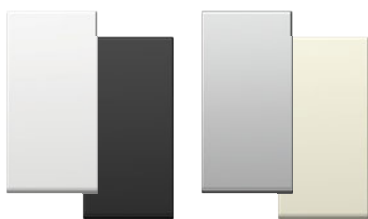

- TM11PW
- TM11SB
- TM11ES
- TM11IW

- zamenljiva tipka velikosti 1M
- ustreza EN 60669-1

BUTTON 1M

- replaceable button 1M
- in accordance with EN 60669-1



TIPKA 1M INDIKATOR



- TM11PWIN
- TM11SBIN
- TM11ESIN
- TM11IWIN

- zamenljiva tipka velikosti 1M
- ustreza EN 60669-1

BUTTON 1M INDICATOR

- replaceable button 1M
- in accordance with EN 60669-1



TIPKA 2M

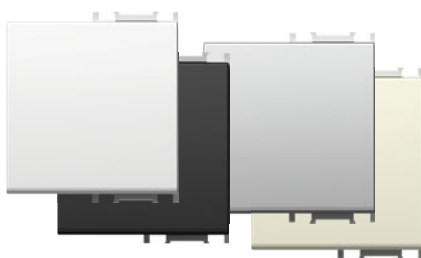

- TM12PW
- TM12SB
- TM12ES
- TM12IW

- zamenljiva tipka velikost 2M z nosilcem tipke
- uporablja se pri nadgradnji stikala ali tipkala
velikosti 1M v velikost 2M
- ustreza EN 60669-1

BUTTON 2M

- replaceable button 2M with button carrier
- to upgrade switch or push button
from size 1M to size 2M
- in accordance with EN 60669-1



TIPKA 2M INDIKATOR

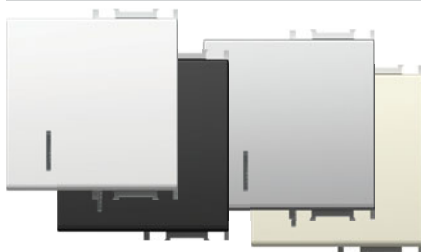

- TM12PWIN
- TM12SBIN
- TM12ESIN
- TM12IWIN

- zamenljiva tipka velikost 2M z nosilcem tipke
- uporablja se pri nadgradnji stikala ali tipkala
velikosti 1M v velikost 2M
- ustreza EN 60669-1

BUTTON 2M INDICATOR

- replaceable button 2M with button carrier
- to upgrade switch or push button
from size 1M to size 2M
- in accordance with EN 60669-1



TIPKA 2M Z NAPISNO PLOŠČICO

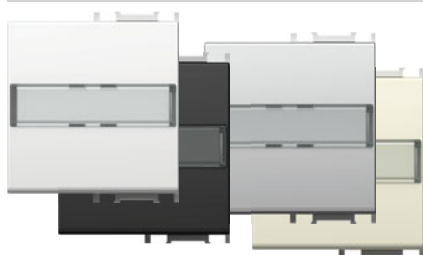

- TM13PWIL
- TM13SBIL
- TM13ESIL
- TM13IWIL

- zamenljiva tipka velikost 2M z nosilcem tipke
 - uporablja se pri nadgradnji stikala ali tipkala velikosti 1M v velikost 2M
 - ustreza EN 60669-1

BUTTON 2M WITH INSCRIPTION PLATE

- replaceable button 2M with button carrier
 - to upgrade switch or push button from size 1M to size 2M
 - in accordance with EN 60669-1



TIPKA 1M DVOPOLNA

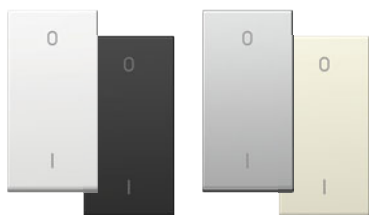

- TM15PW
- TM15SB
- TM15ES
- TM15IW

- zamenljiva tipka velikosti 1M
 - samo v kombinaciji z mehanizmom SM20
 - ustreza EN 60669-1

BUTTON 1M 2POLE

- replaceable button 1M
 - only in combination with mechanism SM20
 - in accordance with EN 60669-1



POLNILO 1M

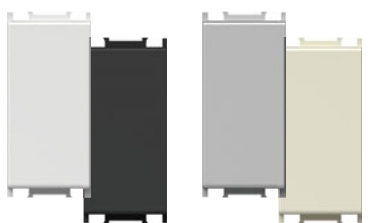

- TM21PW
- TM21SB
- TM21ES
- TM21IW

- za zapolnjevanje praznih mest
 - ustreza EN 60669-1

BLANK 1M

- blank modul to fill up empty spaces
 - in accordance with EN 60669-1



POLNILO 2M

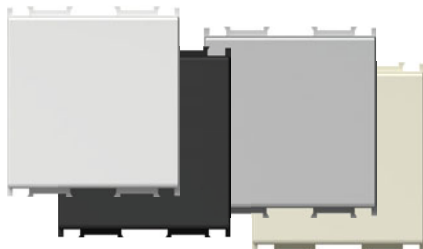

- TM22PW
- TM22SB
- TM22ES
- TM22IW

- za zapolnjevanje praznih mest
 - ustreza EN 60669-1

BLANK 2M

- blank modul to fill up empty spaces
 - in accordance with EN 60669-1



UVODNICA 1M

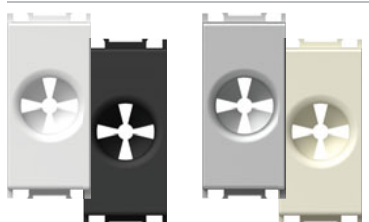

- TM31PW
- TM31SB
- TM31ES
- TM31IW

- uvodnica za kabel
 - ustreza EN-60669-1

CABLE OUTLET 1M

- outlet for cable
 - in accordance with EN-60669-1



1M = 22,5 x 45
 2M = 45 x 45

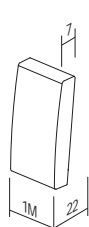

TM11
 TM15

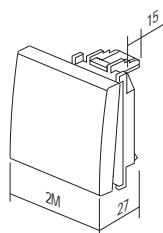

TM12
 TM13

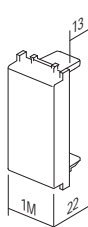

TM21

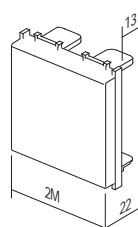

TM22

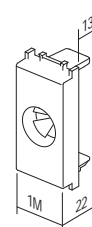

TM31

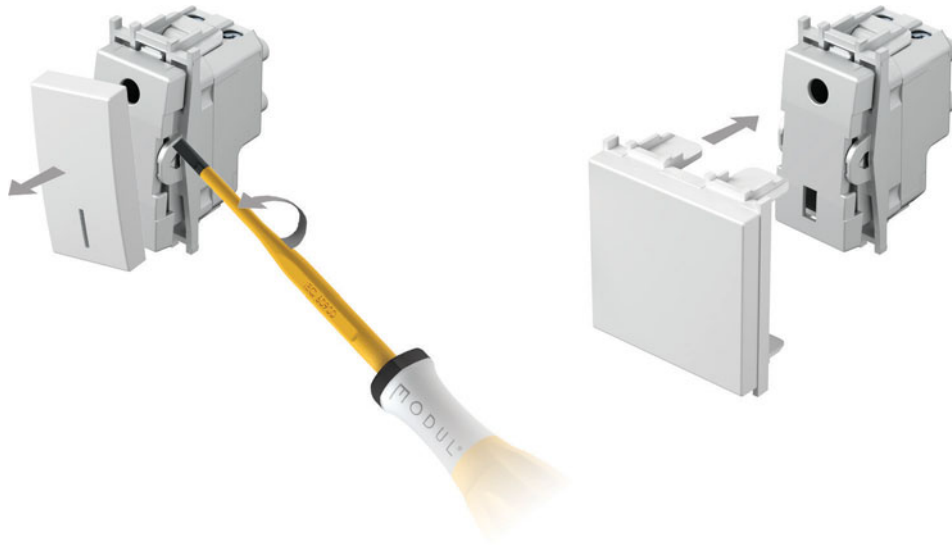

LASERSKI TISK NA TIPKE

- laserski tisk poljubne grafike na označena mesta
- standardni simboli iz zaloge, ostali po naročilu

LASER PRINT ON BUTTONS

- laser print of any graphics on marked locations
- standard symbols from stock, other on request

1M

A
B
C

2M

A	D	G
B	E	H
C	F	I



GRAFIKE
SYMBOLS

01	02	03	04	05	06	07	08	09	10	11	12	20	21	22	23
24	25	26	27	28	29	30	31	32	33	34	35	36	37	38	39
					OFF	ON					AC				
40	41	42	43	44	45	46	47	48							

STANDARDNE GRAFIKE
STANDARD SYMBOLS

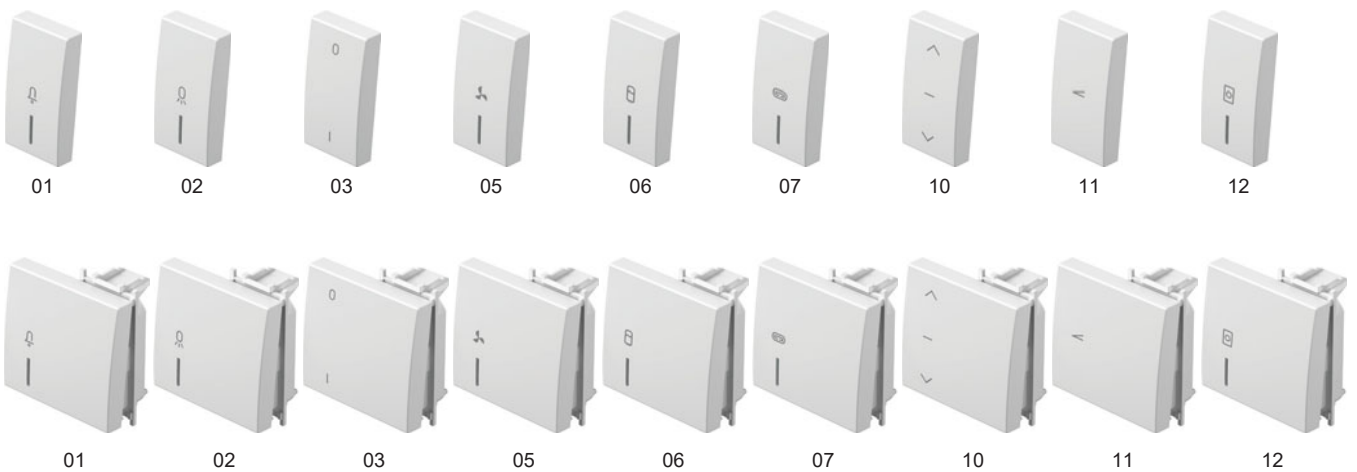

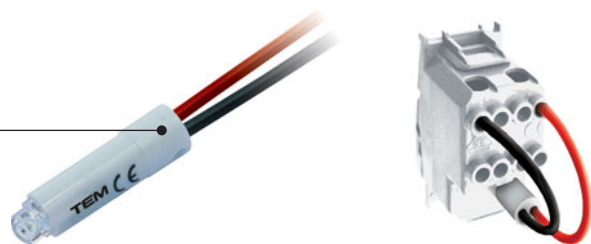

IA20

WH

tip type	naziv description	tehnični opis technical data	barva colour
IA10	TLIVKA NEON LAMP	230V~ 0,34W	<input type="checkbox"/> WH bela white
IA20	SIJALKA LED LED LAMP	230V~ 0,40W	<input checked="" type="checkbox"/> BL modra blue
IA21	SIJALKA LED LED LAMP	24V AC/DC 0,20W	<input checked="" type="checkbox"/> RD rdeča red
.	.	.	<input checked="" type="checkbox"/> GR zelena green
.	.	.	<input checked="" type="checkbox"/> OR oranžna orange

TLIVKA 230V~ 0,34W



IA10OR

- za indikacijo, osvetlitev ali stalno osvetlitev stikala
- v kombinaciji s tipko z indikatorjem

NEON LAMP 230V~ 0,34W
- for indication, illumination or constant illumination of switch
- in combination with button with indicator

SIJALKA LED 230V AC/DC 0,40W



IA20WH
 IA20GR
 IA20RD
 IA20BL

- za indikacijo, osvetlitev ali stalno osvetlitev stikala
- v kombinaciji s tipko z indikatorjem

LED LAMP 230V AC/DC 0,40W
- for indication, illumination or constant illumination of switch
- in combination with button with indicator

SIJALKA LED 24V AC/DC 0,20W



IA21WH
 IA21RD

- za indikacijo, osvetlitev ali stalno osvetlitev stikala
- v kombinaciji s tipko z indikatorjem

LED LAMP 24V AC/DC 0,20W
- for indication, illumination or constant illumination of switch
- in combination with button with indicator

SIJALKA LED 12V AC/DC 0,10W



IA22WH
 IA22RD

- za indikacijo, osvetlitev ali stalno osvetlitev stikala
- v kombinaciji s tipko z indikatorjem

LED LAMP 12V AC/DC 0,10W
- for indication, illumination or constant illumination of switch
- in combination with button with indicator

I L L U M I N A T I O N I A

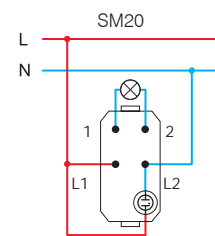
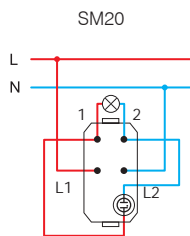
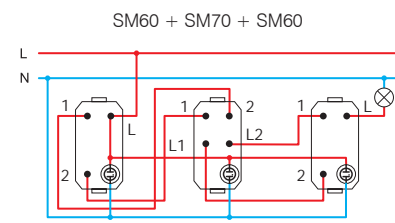
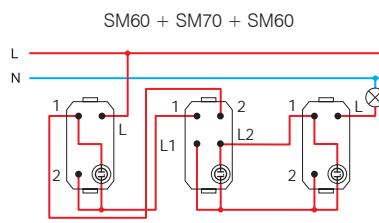
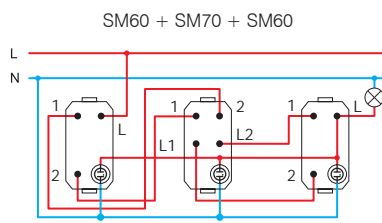
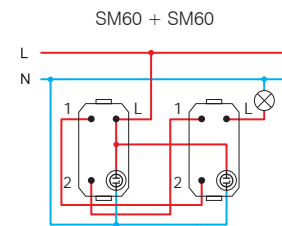
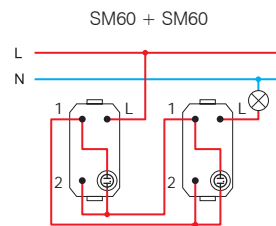
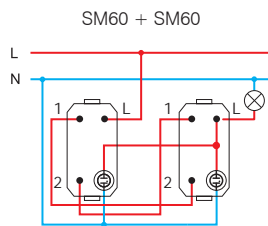
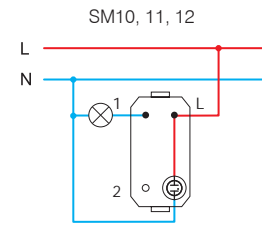
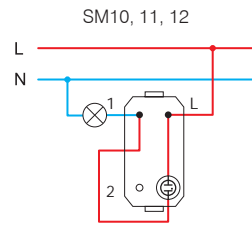
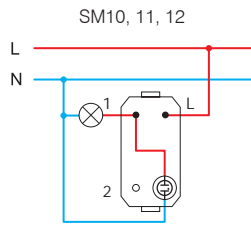
Indikacija/ *
IndicationOsvelitev/
IlluminationStalna osvetlitev/ *
Constant illumination

* vezave primerne za varčne (CFL) sijalke / wiring scheme for compact fluid lamp (CFL)

1M = 22,5 x 45
2M = 45 x 45

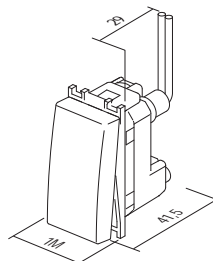

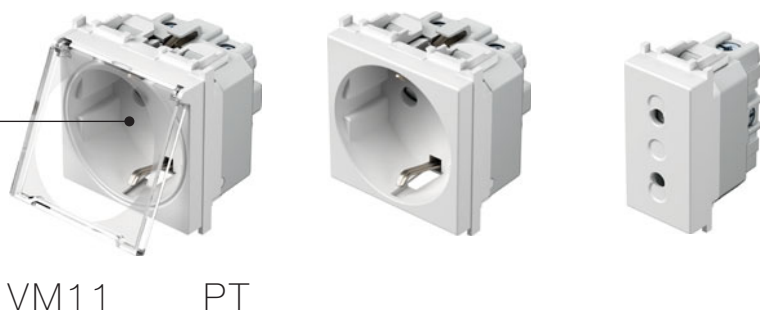

tip type	naziv description	tehnični opis technical data	velikost size	barva colour																																										
VM10	VTIČNICA SCHUKO+KS SOCKET SCHUKO+KS	2P+E 16A 250V~ 2M	2M	<table border="0"> <tr> <td><input type="checkbox"/> PW</td> <td>bela-sijaj polar white</td> <td><input checked="" type="checkbox"/> PT</td> <td>bela+prozorna white+transparent</td> <td><input type="checkbox"/> PP</td> <td>bela+bela white+white</td> </tr> <tr> <td><input checked="" type="checkbox"/> SB</td> <td>črna-mat soft touch black</td> <td><input checked="" type="checkbox"/> BT</td> <td>črna+prozorna soft touch black+transparent</td> <td><input checked="" type="checkbox"/> BB</td> <td>črna+črna soft touch black+black</td> </tr> <tr> <td><input type="checkbox"/> ES</td> <td>srebrna-mat elox silver</td> <td><input checked="" type="checkbox"/> ST</td> <td>srebrna+prozorna silver+transparent</td> <td><input type="checkbox"/> SS</td> <td>srebrna+srebrna silver+silver</td> </tr> <tr> <td><input type="checkbox"/> IW</td> <td>bež-sijaj ivory+white</td> <td><input checked="" type="checkbox"/> IT</td> <td>bež+prozorna ivory+transparent</td> <td><input type="checkbox"/> II</td> <td>bež+bež ivory+ivory</td> </tr> <tr> <td><input checked="" type="checkbox"/> RD</td> <td>rdeča red</td> <td><input checked="" type="checkbox"/> RT</td> <td>rdeča+prozorna red+transparent</td> <td><input checked="" type="checkbox"/> RR</td> <td>rdeča+rdeča red+red</td> </tr> <tr> <td><input checked="" type="checkbox"/> GR</td> <td>zelena green</td> <td><input checked="" type="checkbox"/> GT</td> <td>zelena+prozorna green+transparent</td> <td><input checked="" type="checkbox"/> GG</td> <td>zelena+zelena green+green</td> </tr> <tr> <td><input checked="" type="checkbox"/> OR</td> <td>oranžna orange</td> <td><input checked="" type="checkbox"/> OT</td> <td>oranžna+prozorna orange+transparent</td> <td><input checked="" type="checkbox"/> OO</td> <td>oranžna+oranžna orange+orange</td> </tr> </table>	<input type="checkbox"/> PW	bela-sijaj polar white	<input checked="" type="checkbox"/> PT	bela+prozorna white+transparent	<input type="checkbox"/> PP	bela+bela white+white	<input checked="" type="checkbox"/> SB	črna-mat soft touch black	<input checked="" type="checkbox"/> BT	črna+prozorna soft touch black+transparent	<input checked="" type="checkbox"/> BB	črna+črna soft touch black+black	<input type="checkbox"/> ES	srebrna-mat elox silver	<input checked="" type="checkbox"/> ST	srebrna+prozorna silver+transparent	<input type="checkbox"/> SS	srebrna+srebrna silver+silver	<input type="checkbox"/> IW	bež-sijaj ivory+white	<input checked="" type="checkbox"/> IT	bež+prozorna ivory+transparent	<input type="checkbox"/> II	bež+bež ivory+ivory	<input checked="" type="checkbox"/> RD	rdeča red	<input checked="" type="checkbox"/> RT	rdeča+prozorna red+transparent	<input checked="" type="checkbox"/> RR	rdeča+rdeča red+red	<input checked="" type="checkbox"/> GR	zelena green	<input checked="" type="checkbox"/> GT	zelena+prozorna green+transparent	<input checked="" type="checkbox"/> GG	zelena+zelena green+green	<input checked="" type="checkbox"/> OR	oranžna orange	<input checked="" type="checkbox"/> OT	oranžna+prozorna orange+transparent	<input checked="" type="checkbox"/> OO	oranžna+oranžna orange+orange
<input type="checkbox"/> PW	bela-sijaj polar white	<input checked="" type="checkbox"/> PT	bela+prozorna white+transparent	<input type="checkbox"/> PP	bela+bela white+white																																									
<input checked="" type="checkbox"/> SB	črna-mat soft touch black	<input checked="" type="checkbox"/> BT	črna+prozorna soft touch black+transparent	<input checked="" type="checkbox"/> BB	črna+črna soft touch black+black																																									
<input type="checkbox"/> ES	srebrna-mat elox silver	<input checked="" type="checkbox"/> ST	srebrna+prozorna silver+transparent	<input type="checkbox"/> SS	srebrna+srebrna silver+silver																																									
<input type="checkbox"/> IW	bež-sijaj ivory+white	<input checked="" type="checkbox"/> IT	bež+prozorna ivory+transparent	<input type="checkbox"/> II	bež+bež ivory+ivory																																									
<input checked="" type="checkbox"/> RD	rdeča red	<input checked="" type="checkbox"/> RT	rdeča+prozorna red+transparent	<input checked="" type="checkbox"/> RR	rdeča+rdeča red+red																																									
<input checked="" type="checkbox"/> GR	zelena green	<input checked="" type="checkbox"/> GT	zelena+prozorna green+transparent	<input checked="" type="checkbox"/> GG	zelena+zelena green+green																																									
<input checked="" type="checkbox"/> OR	oranžna orange	<input checked="" type="checkbox"/> OT	oranžna+prozorna orange+transparent	<input checked="" type="checkbox"/> OO	oranžna+oranžna orange+orange																																									
VM11	VTIČNICA SCHUKO+KS+POKROV SOCKET SCHUKO+KS+COVER	2P+E 16A 250V~ 2M	2M																																											
VM20	VTIČNICA EURO+KS SOCKET EURO+KS	2P 10A 250V~	1M																																											



VTIČNICA SCHUKO+KS 2P+E 16A 250V~ 2M

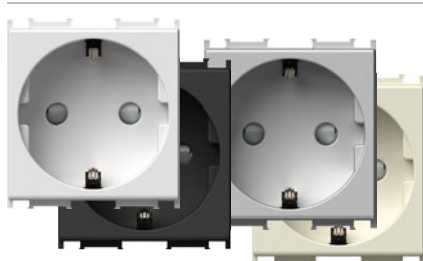

- VM10PW
- VM10SB
- VM10ES
- VM10IW

- 2P+E schuko
- 16A 250V~, tip VM10
- ustreza IEC 60884-1, CEE7
- vijačna pritrditev vodnikov 1.5-2.5 mm²
- KS vgrajena otroška zaščita pred dotikom kontaktov

SOCKET SCHUKO+KS 2P+E 16A 250V~ 2M

- 2P+E schuko
- 16A 250V~, type VM10
- in accordance with IEC 60884-1, CEE7
- screw contacts 1.5-2.5 mm²
- KS build-in child protection - shuttered live contacts



VTIČNICA SCHUKO+KS 2P+E 16A 250V~ 2M

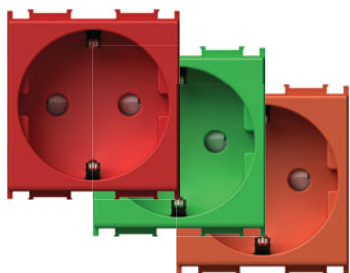

- VM10RD
- VM10GR
- VM10OR

- 2P+E schuko
- 16A 250V~, tip VM10
- ustreza IEC 60884-1, CEE7
- vijačna pritrditev vodnikov 1.5-2.5 mm²
- KS vgrajena otroška zaščita pred dotikom kontaktov

SOCKET SCHUKO+KS 2P+E 16A 250V~ 2M

- 2P+E schuko socket
- 16A 250V~, type VM10
- in accordance with IEC 60884-1, CEE7
- screw contacts 1.5-2.5 mm²
- KS build-in child protection - shuttered live contacts



VTIČNICA SCHUKO+KS+POKROV 2P+E 16A 250V~ 2M

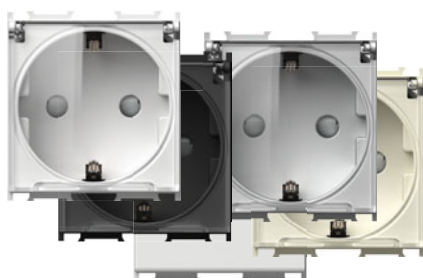

- VM11PT
- VM11BT
- VM11ST
- VM11IT
- VM11PP

- 2P+E schuko+pokrov
- 16A 250V~, tip VM11
- ustreza IEC 60884-1, CEE7
- vijačna pritrditev vodnikov 1.5-2.5 mm²
- KS vgrajena otroška zaščita pred dotikom kontaktov

SOCKET SCHUKO+KS+COVER

- 2P+E 16A 250V~ 2M
- 2P+E schuko+cover
- 16A 250V~, type VM11
- in accordance with IEC 60884-1, CEE7
- screw contacts 1.5-2.5 mm²
- KS build-in child protection - shuttered live contacts



S O C K E T S V M

VTIČNICA EURO+KS 2P 10A 250V~ 1M

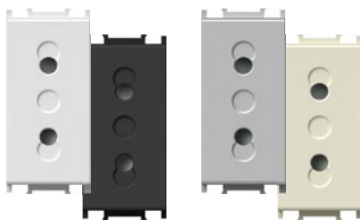

- VM20PW
- VM20SB
- VM20ES
- VM20IW

- 2P euro
- 10A 250V~, tip VM20
- ustreza IEC 60884-1, CEE7
- vijačna pritrditev vodnikov 1.5-2.5 mm²
- KS vgrajena otroška zaščita pred dotikom kontaktov

SOCKET EURO+KS 2P 10A 250V~ 1M

- 2P Euro
- 10A 250V~, type VM20
- in accordance with IEC 60884-1, CEE7
- screw contacts 1.5-2.5 mm²
- KS build-in child protection - shuttered live contacts



VTIČNICA FRANCOSKA+KS 2P+E 16A 250V~ 2M



- VM40PW
- VM40SB
- VM40ES
- VM40IW

- 2P+E francoska
- 16A 250V~, tip VM40
- ustreza IEC 60884-1, NF C 61-314, CEE7
- vijačna pritrditev vodnikov 1.5-2.5 mm²
- KS vgrajena otroška zaščita pred dotikom kontaktov

SOCKET FRENCH+KS 2P+E 16A 250V~ 2M

- 2P+E French
- 16A 250V~, type VM40
- in accordance with IEC 60884-1, NF C 61-314, CEE7
- screw contacts 1.5-2.5 mm²
- KS build-in child protection - shuttered live contacts



VTIČNICA FRANCOSKA+KS 2P+E 16A 250V~ 2M

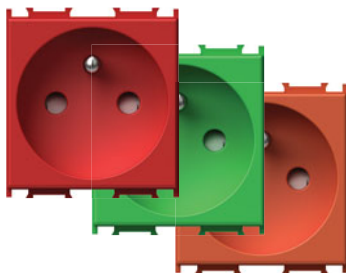

- VM40RD
- VM40GR
- VM40OR

- 2P+E francoska
- 16A 250V~, tip VM40
- ustreza IEC 60884-1, NF C 61-314, CEE7
- vijačna pritrditev vodnikov 1.5-2.5 mm²
- KS vgrajena otroška zaščita pred dotikom kontaktov

SOCKET FRENCH+KS 2P+E 16A 250V~ 2M

- 2P+E French
- 16A 250V~, type VM40
- in accordance with IEC 60884-1, NF C 61-314, CEE7
- screw contacts 1.5-2.5 mm²
- KS build-in child protection - shuttered live contacts



VTIČNICA FRANCOSKA+KS+POKROV 2P+E 16A 250V~ 2M



- VM41PT
- VM41BT
- VM41ST
- VM41IT

- 2P+E francoska+pokrov
- 16A 250V~, tip VM41
- ustreza IEC 60884-1, NF C 61-314, CEE7
- vijačna pritrditev vodnikov 1.5-2.5 mm²
- KS vgrajena otroška zaščita pred dotikom kontaktov

SOCKET FRENCH+KS+COVER

- 2P+E 16A 250V~ 2M
- 2P+E French+cover
- 16A 250V~, type VM41
- in accordance with IEC 60884-1, NF C 61-314, CEE7
- screw contacts 1.5-2.5 mm²
- KS build-in child protection - shuttered live contacts



VTIČNICA ITALIJANSKA P17/11+KS 2P+E 16A 250V~ 1M

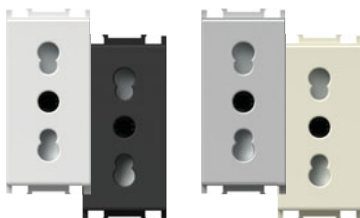

- VM30PW
- VM30SB
- VM30ES
- VM30IW

- 2P+E italijanska P17/11
- 16A 250V~, tip VM30
- ustreza IEC 60884-1, CEI 23-50
- vijačna pritrditev vodnikov 1.5-2.5 mm²
- KS vgrajena otroška zaščita pred dotikom kontaktov

SOCKET ITALIAN P17/11+KS 2P+E 16A 250V~ 1M

- 2P+E Italian P17/11
- 16A 250V~, type VM30
- in accordance with IEC 60884-1, CEI 23-50
- screw contacts 1.5-2.5 mm²
- KS build-in child protection - shuttered live contacts



VTIČNICA SCHUKO/ITA P17/11+KS 2P+E 16A 250V~ 2M

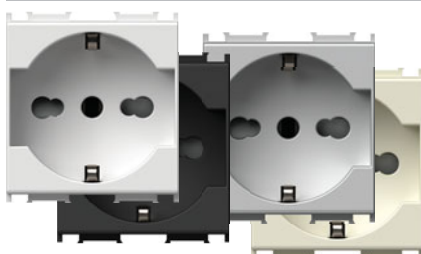

- VM31PW
- VM31SB
- VM31ES
- VM31IW

- 2P+E schuko/italijanska P17/11
- 16A 250V~, tip VM31
- ustreza IEC 60884-1, CEI 23-50
- vijačna pritrditev vodnikov 1.5-2.5 mm²
- KS vgrajena otroška zaščita pred dotikom kontaktov

SOCKET SCHUKO/ITA P17/11+KS

- 2P+E 16A 250V~ 2M
- 2P+E schuko/italian P17/11
- 16A 250V~, type VM31
- in accordance with IEC 60884-1, CEI 23-50
- screw contacts 1.5-2.5 mm²
- KS build-in child protection - shuttered live contacts



VTIČNICA SCHUKO/ITA P30+KS 2P+E 16A 250V~ 2M

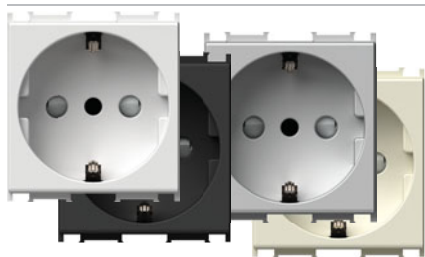

- VM32PW
- VM32SB
- VM32ES
- VM32IW

- 2P+E schuko/italijanska P30
- 16A 250V~, tip VM32
- ustreza IEC 60884-1, CEI 23-50
- vijačna pritrditev vodnikov 1.5-2.5 mm²
- KS vgrajena otroška zaščita pred dotikom kontaktov

SOCKET SCHUKO/ITA P30+KS

- 2P+E 16A 250V~ 2M*
- 2P+E schuko/italian P30
- 16A 250V~, type VM32
- in accordance with IEC 60884-1, CEI 23-50
- screw contacts 1.5-2.5 mm²
- KS build-in child protection - shuttered live contacts



VTIČNICA ITALIJANSKA P11+KS 2P+E 10A 250V~ 1M

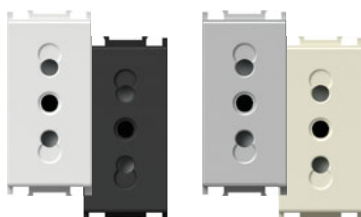

- VM33PW
- VM33SB
- VM33ES
- VM33IW

- 2P+E italijanska P11
- 10A 250V~, tip VM33
- ustreza IEC 60884-1, CEI 23-50
- vijačna pritrditev vodnikov 1.5-2.5 mm²
- KS vgrajena otroška zaščita pred dotikom kontaktov

SOCKET ITALIAN P11+KS 2P+E 10A 250V~ 1M

- 2P+E Italian P11*
- 10A 250V~, type VM33
- in accordance with IEC 60884-1, CEI 23-50
- screw contacts 1.5-2.5 mm²
- KS build-in child protection - shuttered live contacts



VTIČNICA EURO/AMERIŠKA+KS 2P 16A 250V~ 1M



- VM21PW
- VM21SB
- VM21ES
- VM21IW

- 2P euro/ameriška
- 16A 250V~, tip VM21
- vijačna pritrditev vodnikov 1.5-2.5 mm²
- KS vgrajena otroška zaščita pred dotikom kontaktov
- samo za države izven EU

SOCKET EURO/AMERICAN+KS 2P 16A 250V~ 1M

- 2P Euro/American*
- 16A 250V~, type VM21
- screw contacts 1.5-2.5 mm²
- KS build-in child protection - shuttered live contacts
- only for countries not members of EU



VTIČNICA BRITANSKA BS 546+KS 2P+E 15A 250V~ 2M

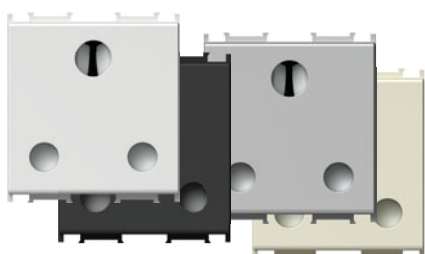

- VM51PW
- VM51SB
- VM51ES
- VM51IW

- 2P+E britanski standard BS 546
- 15A 250V~, tip VM51
- ustreza BS 546
- vijačna pritrditev vodnikov 1.5-4 mm²
- vgrajena zaščita pred dotikom kontaktov

SOCKET BRITISH BS 546+KS 2P+E 15A 250V~ 2M

- 2P+E British BS 546*
- 15A 250V~, type VM51
- in accordance with BS 546
- screw contacts 1.5-4 mm²
- KS build-in child protection - shuttered live contacts



VTIČNICA BRITANSKA BS 1363-2+KS 2P+E 13A 250V~ 2M

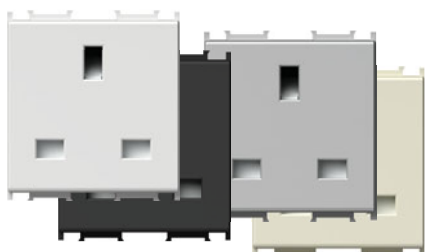

- VM52PW
- VM52SB
- VM52ES
- VM52IW

- 2P+E britanski standard BS 1363-2
- 13A/250V~, tip VM52
- ustreza BS 1363-2
- vijačna pritrditev vodnikov 1.5-4 mm²
- vgrajena zaščita pred dotikom kontaktov

SOCKET BRITISH BS 1363-2+KS 2P+E 13A 250V~ 2M

- 2P+E British BS 1363-2*
- 13A 250V~, type VM52
- in accordance with BS 1363-2
- screw contacts 1.5-4 mm²
- KS build-in child protection - shuttered live contacts



PRENAPETOSTNA ZAŠČITA MPE MINI 275V/50Hz



VM80

- vzporedna vezava s prvo vtičnico v seriji
- razred zaščite III
- $U_c=275V_{ac}$, $U_{oc}/I_{sc}=6kV/3kA$, $U_p<800V$
- ustreza IEC 61643-1
- vodniki 1.5mm², IP20
- zvočni signal ob uničenju

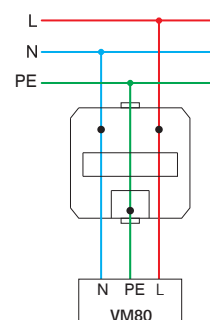

SURGE PROTECTOR MPE MINI 275V/50Hz

- parallel connection with the first socket in the row
- protection class III
- $U_c=275V_{ac}$, $U_{oc}/I_{sc}=6kV/3kA$, $U_p<800V$
- in accordance with IEC 61643-1
- wires 1.5mm², IP20
- sound signal at breakdown





S O C K E T S V M

 UJEMANJE VTIČNIC IN VTIČEV
 SOCKETS AND PLUGS MATCHING

VTIČNICA / SOCKET	VM10 VM11	VM20	VM30	VM33	VM31	VM32	VM40 VM41	VM21
STIL VTIČA / PLUG STYLE								
nemški / German 	•				•	•		
francoski / French 	•				•	•	•	
italijanski / Italian S11 			•	•	•	•		
italijanski / Italian S17 			•	•	•			
euro 	•	•	•		•	•	•	•

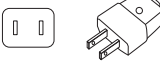
 UJEMANJE VTIČNIC IN VTIČEV
 SOCKETS AND PLUGS MATCHING

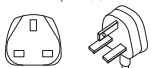
VTIČNICA / SOCKET	VM21	VM51	VM52
STIL VTIČA / PLUG STYLE			
ameriški / American 	•		
britanski / British BS 546 		•	
britanski / British BS 1363-2 			•

1M = 22,5 x 45
2M = 45 x 45

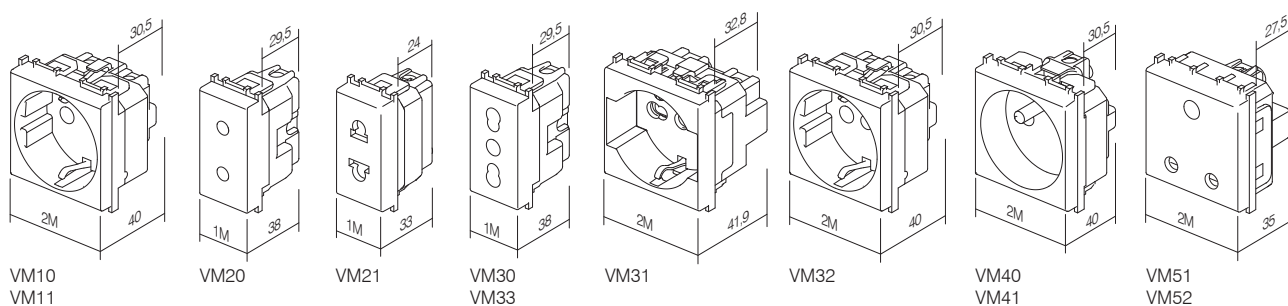



tip type	naziv description	tehnični opis technical data	velikost size	barva colour
KM10	VTIČNICA TV OSNOVNA SOCKET TV BASIC	0dB	1M	<input type="checkbox"/> PW bela-sijaj polar white
KM11	VTIČNICA TV KONČNA SOCKET TV END-LINE	1dB	1M	<input checked="" type="checkbox"/> SB črna-mat soft touch black
KM12	VTIČNICA TV PREHODNA SOCKET TV TROUGHPASS	10dB	1M	<input type="checkbox"/> ES srebrna-mat elox silver
.	.	.	.	<input type="checkbox"/> IW bež-sijaj ivory white

VTIČNICA TV OSNOVNA 0dB 1M

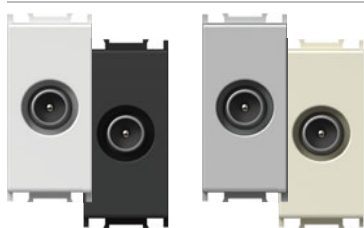

- KM10PW
- KM10SB
- KM10ES
- KM10IW

- TV osnovna
- dušenje 0dB
- konektor zadaj – F standard
SOCKET TV BASIC 0dB 1M
- TV basic
- reduction 0dB
- back connector – F standard



VTIČNICA TV OSNOVNA 0dB 2M

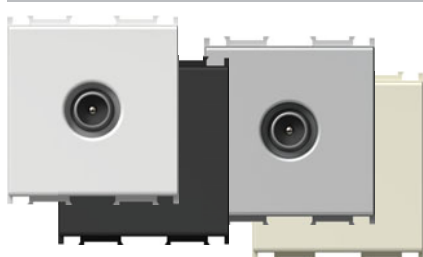

- KM20PW
- KM20SB
- KM20ES
- KM20IW

- TV osnovna
- dušenje 0dB
- konektor zadaj – F standard
SOCKET TV BASIC 0dB 2M
- TV basic
- reduction 0dB
- back connector – F standard



VTIČNICA TV KONČNA 1dB 1M

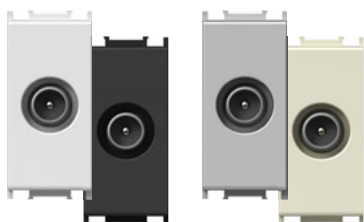

- KM11PW
- KM11SB
- KM11ES
- KM11IW

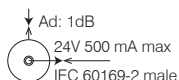

- TV končna
- frekvenčni pas 5÷2400 MHz
- dušenje < 1 dB
- ustreza EN 50083-1
- vijačna priključitev
SOCKET TV END-LINE 1dB 1M
- TV end-line
- frequency range 5÷2400 MHz
- reduction < 1 dB
- in accordance with EN 50083-1
- screw contacts



VTIČNICA TV PREHODNA 10dB 1M

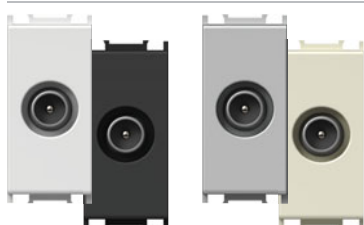

- KM12PW
- KM12SB
- KM12ES
- KM12IW

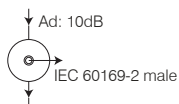

- TV prehodna
- frekvenčni pas 5÷2400 MHz
- dušenje < 10 dB
- ustreza EN 50083-1
- vijačna priključitev
SOCKET TV TROUGHPASS 10dB 1M
- TV troughpass
- frequency range 5÷2400 MHz
- reduction < 10 dB
- in accordance with EN 50083-1
- screw contacts



VTIČNICA SAT OSNOVNA 0dB 1M

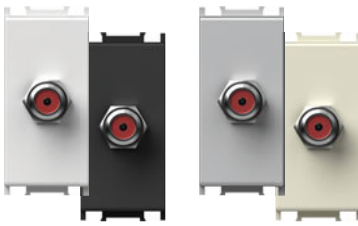

- KM15PW
- KM15SB
- KM15ES
- KM15IW

- SAT osnovna
 - dušenje 0dB
 - konektor zadaj – F standard
- SOCKET SAT BASIC 0dB 1M*
- SAT basic
 - reduction 0dB
 - back connector – F standard



VTIČNICA SAT OSNOVNA 0dB 2M

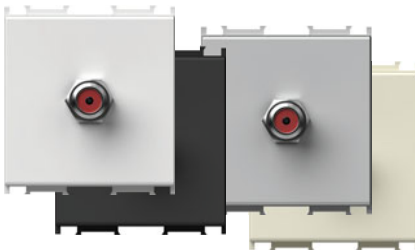

- KM24PW
- KM24SB
- KM24ES
- KM24IW

- SAT osnovna
 - dušenje 0dB
 - konektor zadaj – F standard
- SOCKET SAT BASIC 0dB 2M*
- SAT basic
 - reduction 0dB
 - back connector – F standard



VTIČNICA SAT KONČNA 1dB 1M

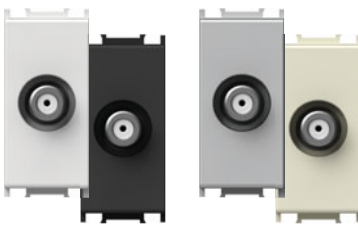

- KM16PW
- KM16SB
- KM16ES
- KM16IW

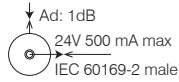

- SAT končna
 - frekvenčni pas 5÷2400 MHz
 - dušenje < 1dB
 - ustreza EN 50083-1
 - vijajčna priključitev
- SOCKET SAT END-LINE 1dB 1M*
- SAT end-line
 - frequency range 5÷2400 MHz
 - reduction < 1dB
 - in accordance with EN 50083-1
 - screw contacts



VTIČNICA R OSNOVNA 0dB 1M



- KM19PW
- KM19SB
- KM19ES
- KM19IW

- R osnovna
 - dušenje 0dB
 - konektor zadaj – F standard
- SOCKET R BASIC 0dB 1M*
- R basic
 - reduction 0dB
 - back connector – F standard



VTIČNICA R OSNOVNA 0dB 2M

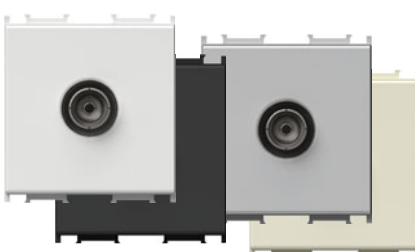

- KM29PW
- KM29SB
- KM29ES
- KM29IW

- R osnovna
 - dušenje 0dB
 - konektor zadaj – F standard
- SOCKET R BASIC 0dB 2M*
- R basic
 - reduction 0dB
 - back connector – F standard



VTIČNICA SAT-TV KONČNA 1dB 2M

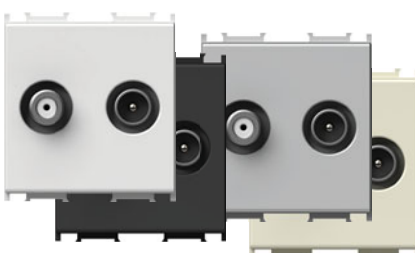

- KM25PW
- KM25SB
- KM25ES
- KM25IW

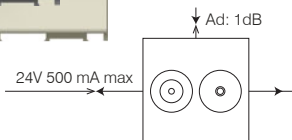

- SAT-TV končna
 - frekvenčni pas 5÷2400 MHz
 - dušenje < 1dB
 - ustreza EN 50083-1
 - vijajčna priključitev
- SOCKET SAT-TV END-LINE 1dB 2M*
- SAT-TV end-line
 - frequency range 5÷2400 MHz
 - reduction < 1dB
 - in accordance with EN 50083-1
 - screw contacts



OSNOVNE VEZALNE SCHEME
BASIC CONNECTION SAMPLES

samostojna vezava
stand alone connection

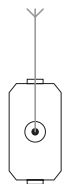

KM10
KM20
KM11
KM15
KM24
KM16
KM19
KM29
KM25

zvezda vezava
star connection

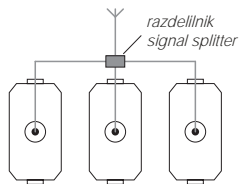

KM10
KM20
KM11
KM15
KM24
KM16
KM19
KM29
KM25

prehodna vezava
throughpass connection

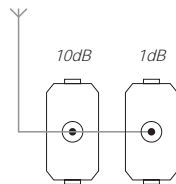

KM12 KM11



- KM22PW
- KM22SB
- KM22ES
- KM22IW

VTIČNICA AVDIO 2xRCA 1M

- avdio 2x RCA
- pritrditev vodnikov zadaj s spajkanjem

SOCKET AUDIO 2xRCA 1M

- audio 2x RCA
- soldering connection of cable at the back side



- KM23PW
- KM23SB
- KM23ES
- KM23IW

VTIČNICA AVDIO ZVOČNIŠKA 1M

- avdio 2x Ø4mm
- za priklop zvočniškega vodnika, vtiča Ø4mm ali viličastega kabel čevlja
- pritrditev vodnikov zadaj s spajkanjem

SOCKET AUDIO LOUDSPEAKERS 1M

- audio 2x Ø4mm
- to accommodate speaker wire, banana plug Ø4mm or spades
- soldering connection of cable at the back side



- KM26PW
- KM26SB
- KM26ES
- KM26IW

VTIČNICA AVDIO ZVOČNIŠKA 2M

- avdio 2x Ø4mm
- za priklop zvočniškega vodnika, vtiča Ø4mm ali viličastega kabel čevlja
- pritrditev vodnikov zadaj s spajkanjem

SOCKET AUDIO LOUDSPEAKERS 2M

- audio 2x Ø4mm
- to accommodate speaker wire, banana plug Ø4mm or spades
- soldering connection of cable at the back side



1M = 22,5 x 45
2M = 45 x 45

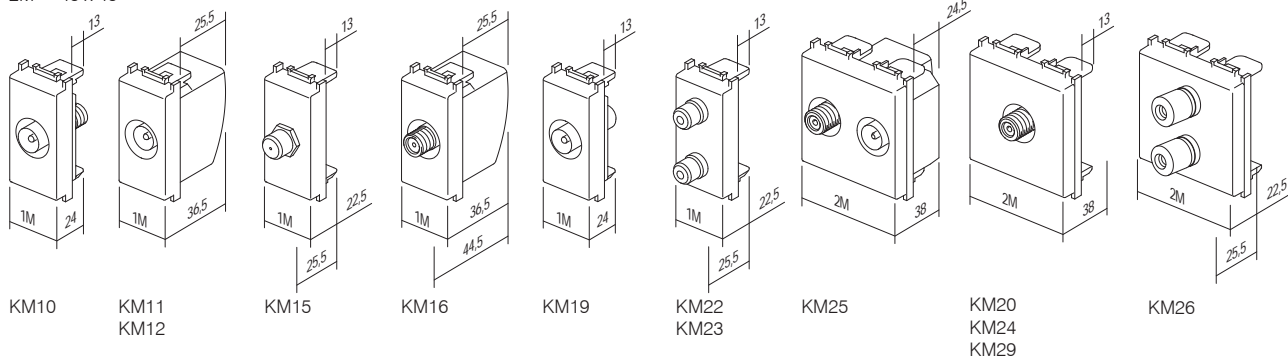

VTIČNICA TEL LT RJ11 6/4 1M

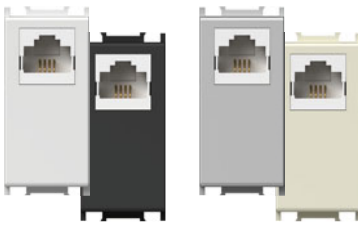

- KM30PW
- KM30SB
- KM30ES
- KM30IW

- TEL LT vijak
- RJ11 6/4
- ustreza IEC 60603-7
- vijačna pritrditev vodnikov

SOCKET TEL LT RJ11 6/4 1M

- TEL LT screw
- RJ11 6/4
- in accordance with IEC 60603-7
- screw contacts



VTIČNICA TEL BT SEC 6/6 1M

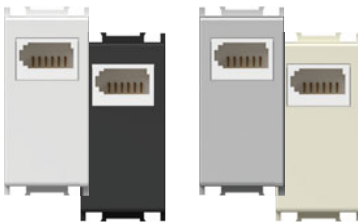

- KM31PW
- KM31SB
- KM31ES
- KM31IW

- TEL BT britanski standard
- SEC sekundarna 6/6
- ustreza BS 6312
- vijačna pritrditev vodnikov

SOCKET TEL BT SEC 6/6 1M

- TEL BT British standard
- SEC secondary 6/6
- in accordance with BS 6312
- screw contacts



VTIČNICA TEL KS RJ11 6/4 1M

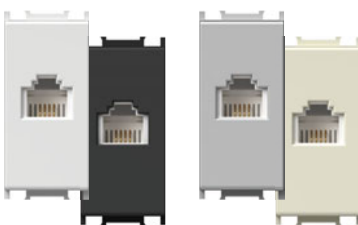

- KM36PW
- KM36SB
- KM36ES
- KM36IW

- KS keystone pritrditveni standard
- RJ11 6/4
- ustreza IEC 60603-7

SOCKET TEL KS RJ11 6/4 1M

- KS keystone fixing standard
- RJ11 6/4
- in accordance with IEC 60603-7



VTIČNICA CAT5e KS RJ45 8/8 1M

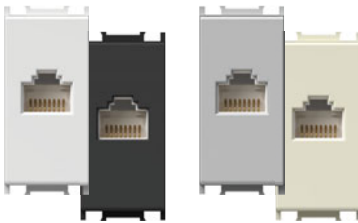

- KM37PW
- KM37SB
- KM37ES
- KM37IW

- KS keystone pritrditveni standard
- CAT5e, RJ45 8/8
- ustreza IEC 60603-7

SOCKET CAT5e KS RJ45 8/8 1M

- KS keystone fixing standard
- CAT5e, RJ45 8/8
- in accordance with IEC 60603-7



ADAPTER KS 1M

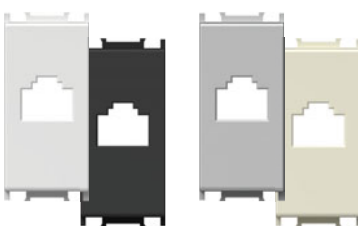

- KM35PW
- KM35SB
- KM35ES
- KM35IW

- KS keystone pritrditveni standard
- AMP, Avaya, Brandrex, FMT, Mfico, Tyco, ...
- komunikacijski modul ni vgrajen

ADAPTER KS 1M

- KS keystone fixing standard
- AMP, Avaya, Brandrex, FMT, Mfico, Tyco, ...
- communication module not included



ADAPTER KS S PRAŠNO ZAŠČITO 1M

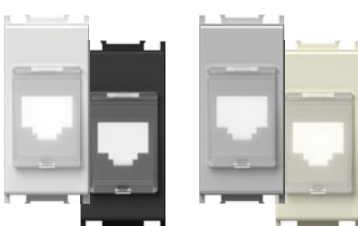

- KM38PW
- KM38SB
- KM38ES
- KM38IW

- KS keystone pritrditveni standard s protiprašnim pokrovom
- AMP, Avaya, Brandrex, FMT, Mfico, Tyco, ...
- komunikacijski modul ni vgrajen

ADAPTER KS WITH DUST PROTECTION 1M

- KS keystone fixing standard with dust protection
- AMP, Avaya, Brandrex, FMT, Mfico, Tyco, ...
- communication module not included



ADAPTER KS UNIVERZALNI 1M

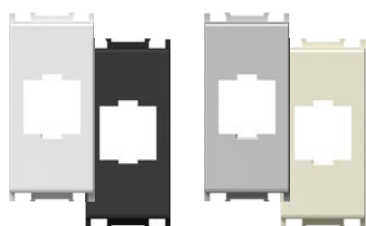

- KM50PW
- KM50SB
- KM50ES
- KM50IW

- KS keystone pritrditveni standard
 - primeren za HDMI, USB
 - komunikacijski modul ni vgrajen

ADAPTER KS UNIVERSAL 1M
 - KS keystone fixing standard
 - suitable for HDMI, USB
 - communication module not included



ADAPTER PD 1M

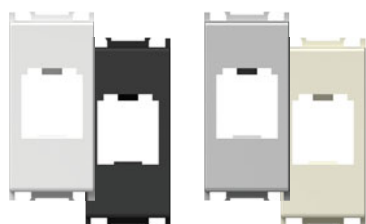

- KM40PW
- KM40SB
- KM40ES
- KM40IW

- PD Panduit Mini-COM pritrditveni standard
 - komunikacijski modul ni vgrajen

ADAPTER PD 1M
 - PD Panduit Mini-COM fixing standard
 - communication module not included



ADAPTER PD S PRAŠNO ZAŠČITO 1M



- KM43PW
- KM43SB
- KM43ES
- KM43IW

- PD Panduit Mini-COM pritrditveni standard s
 protiprašnim pokrovom
 - komunikacijski modul ni vgrajen

ADAPTER PD WITH DUST PROTECTION 1M
 - PD Panduit Mini-COM fixing standard with
 dust protection
 - communication module not included



ADAPTER R&M 1M

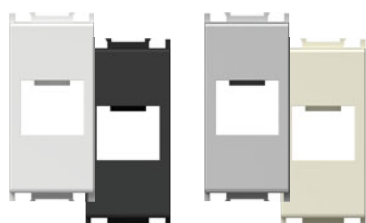

- KM46PW
- KM46SB
- KM46ES
- KM46IW

- R&M pritrditveni standard
 - komunikacijski modul ni vgrajen

ADAPTER R&M 1M
 - R&M fixing standard
 - communication module not included



ADAPTER R&M S PRAŠNO ZAŠČITO 1M



- KM47PW
- KM47SB
- KM47ES
- KM47IW

- R&M pritrditveni standard s protiprašnim pokrovom
 - komunikacijski modul ni vgrajen

ADAPTER R&M WITH DUST PROTECTION 1M
 - R&M fixing standard with dust protection
 - communication module not included



ADAPTER LK 1M

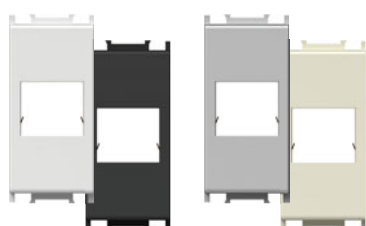

- KM45PW
- KM45SB
- KM45ES
- KM45IW

- LK LeoniKerpen eLine / BKS NewLine pritrditveni standard
 - komunikacijski modul ni vgrajen

ADAPTER LK 1M
 - LK LeoniKerpen eLine / BKS NewLine fixing standard
 - communication module not included



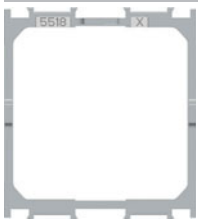

KA26

ADAPTER NEXANS (N423.540N) 2M

- adapter za pritržitev modulov Nexans LANmark velikosti 45x45mm
- primerna za tip N423.540N
- komunikacijski modul ni vgrajen

ADAPTER NEXANS (N423.540N) 2M

- fixing adapter for Nexans LANmark module 45x45mm
- suitable for type N423.540N
- communication module not included

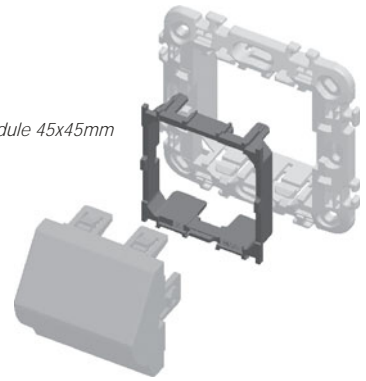

ADAPTER AT&T SYSTEMAX S PRAŠNO ZAŠČITO 1M

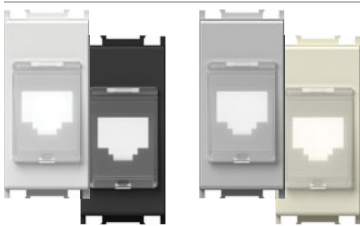

- KM48PW
- KM48SB
- KM48ES
- KM48IW

- AT&T Systemax pritržitveni standard s protiprašnim pokrovom
- komunikacijski modul ni vgrajen

ADAPTER AT&T SYSTEMAX WITH DUST PROTECTION 1M

- AT&T Systemax fixing standard with dust protection
- communication module not included



VTIČNICA USB TIP A 1M



- KM51PW
- KM51SB
- KM51ES
- KM51IW

- USB 2.0 vtičnica tip A
- vijačna pritržitev vodnikov, raster 5 mm, 1,5 mm², 1x2P + 1x3P
- ožičenje:
 - PIN 1 – VCC (+5V, rdeča žica)
 - PIN 2 – signal - (bela žica)
 - PIN 3 – signal + (zelená žica)
 - PIN 4 – GND - masa (črna žica)
 - S – oklop
- ustreza direktivi 2011/95/EU (RoHS2)



SOCKET USB TYPE A 1M

- USB 2.0 socket type A
- screw contacts, raster 5 mm, 1,5 mm², 1x2P + 1x3P
- wiring:
 - PIN 1 – VCC (+5V, red wire)
 - PIN 2 – Data - (white wire)
 - PIN 3 – Data + (green wire)
 - PIN 4 – GND - ground (black wire)
 - S – shield
- in accordance with directive 2011/95/EU (RoHS2)

1M = 22,5 x 45
2M = 45 x 45

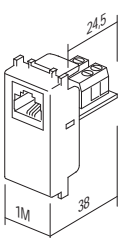

KM30

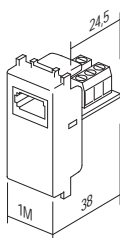

KM31

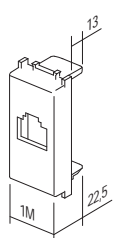

KM35
KM38
KM50
KM48

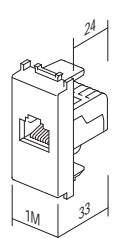

KM36
KM37

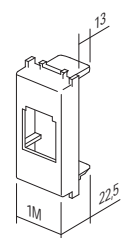

KM40
KM43

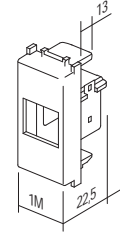

KM45

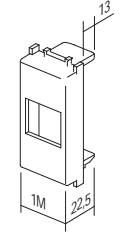

KM46
KM47
KM50

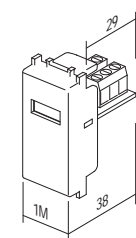

KM51

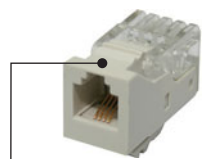

KA10

tip <i>type</i>	naziv <i>description</i>	tehnični opis <i>technical data</i>
KA10	KONEKTOR KS CAT3 <i>CONNECTOR KS CAT3</i>	RJ11 6/4
KA11	KONEKTOR KS CAT5e <i>CONNECTOR KS CAT5e</i>	RJ45 8/8
KA12	KONEKTOR KS CAT5eS <i>CONNECTOR KS CAT5eS</i>	RJ45 8/8
...

KONEKTOR KS CAT3 RJ11 6/4



KA10

- KS keystone pritrditveni standard
- CAT3, RJ11 6/4
- ustreza IEC 60603-7

CONNECTOR KS CAT3 RJ11 6/4

- KS keystone fixing standard
- CAT3, RJ11 6/4
- in accordance with IEC 60603-7

KONEKTOR KS CAT5e RJ45 8/8



KA11

- KS keystone pritrditveni standard
- CAT5e, RJ45 8/8
- ustreza IEC 60603-7

CONNECTOR KS CAT5e RJ45 8/8

- KS keystone fixing standard
- CAT5e, RJ45 8/8
- in accordance with IEC 60603-7

KONEKTOR KS CAT5eS RJ45 8/8



KA12

- KS keystone pritrditveni standard
- CAT5eS, RJ45 8/8
- ustreza IEC 60603-7

CONNECTOR KS CAT5eS RJ45 8/8

- KS keystone fixing standard
- CAT5eS, RJ45 8/8
- in accordance with IEC 60603-7

KONEKTOR KS CAT6 SCH RJ45 8/8



KA15

- KS keystone pritrditveni standard
- CAT6 UTP toolless, RJ45 8/8
- ustreza ISO/IEC 11801

CONNECTOR KS CAT6 SCH RJ45 8/8

- KS keystone fixing standard
- CAT6 UTP toolless, RJ45 8/8
- in accordance with ISO/IEC 11801

KONEKTOR KS CAT6S SCH RJ45 8/8



KA16

- KS keystone pritrditveni standard
- CAT6S STP toolless, RJ45 8/8
- ustreza ISO/IEC 11801

CONNECTOR KS CAT6S SCH RJ45 8/8

- KS keystone fixing standard
- CAT6S STP toolless, RJ45 8/8
- in accordance with ISO/IEC 11801

KONEKTOR KS CAT6a SCH RJ45 8/8



KA17

- KS keystone pritrditveni standard
- CAT6a STP toolless, RJ45 8/8
- ustreza ISO/IEC 11801

CONNECTOR KS CAT6S SCH RJ45 8/8

- KS keystone fixing standard
- CAT6a STP toolless, RJ45 8/8
- in accordance with ISO/IEC 11801



KA27

KONEKTOR KS HDMI

- KS keystone pritrditveni standard
- samo v kombinaciji z adapterjem KM50
- HDMI/HDMI

CONNECTOR KS HDMI

- KS keystone fixing standard
- only in combination with adapter KM50
- HDMI/HDMI



EM31



PW



tip type	naziv description	tehnični opis technical data	velikost size	barva colour
EM10	ZATEMNILNIK ROTACIJSKI <i>DIMMER ROTATIVE</i>	R 300W	1M	<input type="checkbox"/> PW bela-sijaj <i>polar white</i>
EM11	ZATEMNILNIK ROTACIJSKI MENJALNI <i>DIMMER ROTATIVE 2WAY</i>	RL 300W	1M	<input checked="" type="checkbox"/> SB črna-mat <i>soft touch black</i>
EM21	ZATEMNILNIK VGRADNI <i>DIMMER INBOX</i>	RLC 300W	/	<input type="checkbox"/> ES srebrna-mat <i>elox silver</i>
.	.	.	.	<input type="checkbox"/> IW bež-sijaj <i>ivory white</i>
.	.	.	.	<input type="checkbox"/> BL modra <i>blue</i>
.	.	.	.	<input type="checkbox"/> RD rdeča <i>red</i>
.	.	.	.	<input type="checkbox"/> GR zelena <i>green</i>
.	.	.	.	<input type="checkbox"/> OR oranžna <i>orange</i>
.	.	.	.	<input type="checkbox"/> RG rdeča/zelena <i>red/green</i>

ZATEMNILNIK ROTACIJSKI R 300W 1M

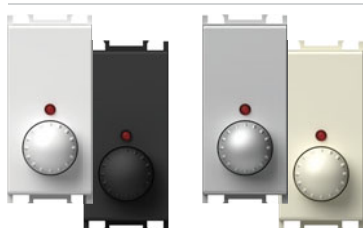

- EM10PW
- EM10SB
- EM10ES
- EM10IW

- rotacijski brez stikala
- tip RTS34.43 RVP, breme R, 40W - 300W
- napajanje 230V~ 50Hz
- vezava z menjalnim stikalom ni možna
- vezava večih zatemnilnikov ni dovoljena
- ustreza EN 60669-1
- vijčna pritrditev vodnikov 1.5-2.5 mm²
- LED indikacija

- DIMMER ROTATIVE R 300W 1M*
- rotation control without switch
 - type RTS34.43 RVP, load R, 40W - 300W
 - supply voltage 230V~ 50Hz
 - 2-way switch combination is not possible
 - more dimmers combination is not allowed
 - in accordance with EN 60669-1
 - screw contacts 1.5-2.5mm²
 - LED indication



ZATEMNILNIK ROTACIJSKI/MENJALNI RL 300W 1M

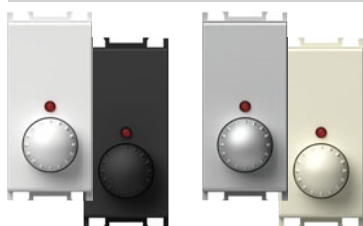

- EM11PW
- EM11SB
- EM11ES
- EM11IW

- rotacijski z menjalnim stikalom
- tip RTS34 DVP, breme RL, 40W - 300W
- napajanje 230V~ 50Hz
- možna vezava z menjalnim stikalom
- vezava večih zatemnilnikov ni dovoljena
- vgrajena spominska funkcija
- ustreza EN 60669-1
- vijčna pritrditev vodnikov 1.5-2.5 mm²
- LED indikacija

- DIMMER ROTATIVE 2WAY RL 300W 1M*
- rotation control with 2-way switch
 - type RTS34 DVP, load RL, 40W - 300W
 - supply voltage 230V~ 50Hz
 - 2-way switch combination is possible
 - more dimmers combination is not allowed
 - light intensity memory
 - in accordance with EN 60669-1
 - screw contacts 1.5-2.5mm²
 - LED indication





EM21

ZATEMNILNIK VGRADNI RLC 300W

- vgradni, za vezavo s tipkalom
- tip RHUN, breme RLC, 25W - 300W ali 25VA - 250VA
- napajanje 230V~ 50Hz
- možna vezava z več tipkali
- vezava večih zatemnilnikov ni dovoljena
- vgrajena spominska funkcija
- funkcija mehkega vklopa / izklopa
- ustreza EN 61058-1
- vodniki 1.5mm²



DIMMER INBOX RLC 300W

- inbox, controlled by external push button
- type RHUN, load RLC, 25W - 300W or 25VA - 250VA
- supply voltage 230V~ 50Hz
- several push-buttons combination is possible
- more dimmers combination is not allowed
- light intensity memory
- soft start / stop function
- in accordance with EN 61058-1
- wires 1.5mm²



EM22

ZATEMNILNIK VGRADNI R 500W

- vgradni, za vezavo s tipkalom
- tip RTL500UN, breme R, 40W - 500W
- napajanje 230V~ 50Hz
- možna vezava z več tipkali
- vezava večih zatemnilnikov ni dovoljena
- vgrajena spominska funkcija
- funkcija mehkega vklopa / izklopa
- ustreza EN 61058-1
- vijačna pritrditev vodnikov 1.5-2.5 mm²

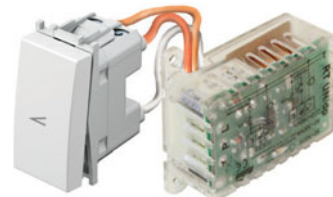

DIMMER INBOX R 500W

- inbox, controlled by external push button
- type RTL500UN, load R, 40W - 500W
- supply voltage 230V~ 50Hz
- several push-buttons combination is possible
- more dimmers combination is not allowed
- light intensity memory
- soft start / stop function
- in accordance with EN 61058-1
- screw contacts 1.5-2.5mm²

EM10 (40÷300W)
EM22 (40÷500W)

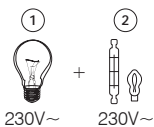

EM11 (40÷300W)

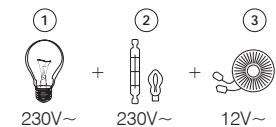

EM21 (25÷300W, 25÷250VA)

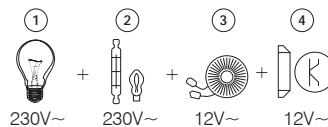

- 1 - žarnica z žarilno nitko / incandescent lamp
- 2 - halogenska žarnica / halogen lamp
- 3 - klasični transformator / classical transformer
- 4 - elektronski transformator / electronic transformer

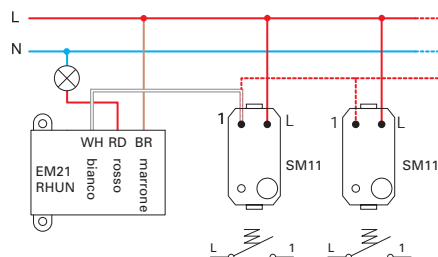
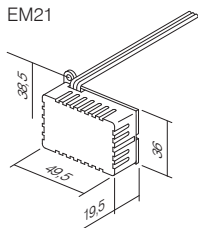
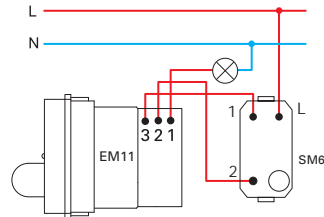
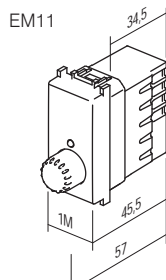
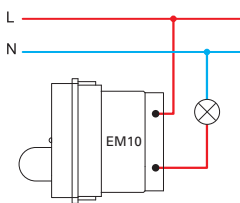
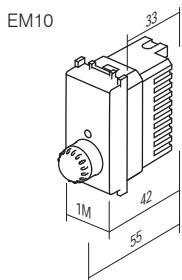

POZOR!

V primeru montaže več zatemnilnih stikal v isto dozo se za vsako dodatno zatemnilno stikalo zmanjša maksimalna skupna moč za 10%.

ATTENTION!

If more dimmers are connected in one box reduce maximum common power for 10% for each dimmer.

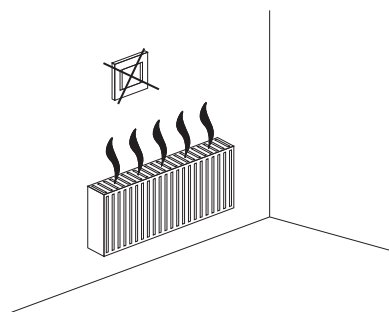
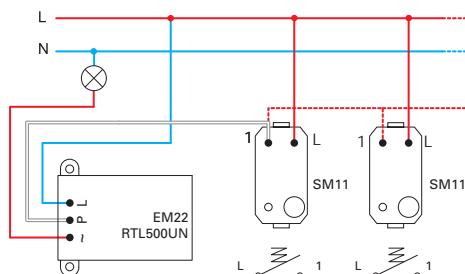
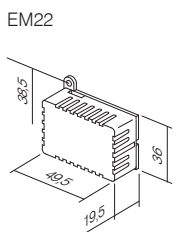

STIKALO / ZATEMNILNIK UNIVERZALNI RLC 0-300W 2M



- EM25PW
- EM25SB
- EM25ES
- EM25IW

- univerzalni elektronski zatemnilnik za vklop, izklop in zatemnjevanje vseh zatemnilnih žarnic in sijalk (klasične, halogenske, LED, CFL, ...) in nekaterih nezatemnilnih sijalk
- samodejno zazna vrsto sijalke in temu prilagodi režim delovanja
- z zatemnjevanjem se zmanjša poraba električne energije
- funkcija mehkega zagona podaljša življenjsko dobo sijalk
- upravljanje preko vgrajenih mikro-stikal
- vgrajena spominska funkcija - ob izklopu si zapomni nivo zatemnitve
- možna vezava do pet (5) dodatnih upravljalnih tipkal EM26
- vezava z menjalnimi stikali ni možna
- vgrajene zaščite pred kratkim stikom, pregrevanjem in preobremenitvijo
- napajanje 230V~ 50Hz
- vgrajena elegantna LED osvetlitev, z možnostjo nastavitve barve in jakosti
- omogoča zamenjavo klasičnega stikala – dvožična vezava⁽¹⁾
- s trožično vezavo dosežemo polno funkcionalnost zatemnilnika⁽²⁾
- ustreza EN 60669-1 in EN 60669-2-1
- vijačna pritrditev vodnikov 1.5mm² (maks. moment pritvija vijakov 0,4 Nm)



TOUCH EM25 je mikroprocesorsko voden elektronski zatemnilnik. Omogoča vklop, izklop in zatemnjevanje vseh zatemnilnih in nekaterih nezatemnilnih žarnic in sijalk. Vgrajeni mikroprocesor samodejno zazna vrsto sijalke in prilagodi režim delovanja. Ob izklopu si zapomni zadnjo nastavitve, saj ima vgrajeno spominsko funkcijo. Funkcija mehkega zagona podaljša življenjsko dobo sijalk. V tipko je vgrajena elegantna LED osvetlitev, z možnostjo izbire barve in nastavitve jakosti. Na EM25 lahko vezemo do 5 dodatnih upravljalnih tipkal EM26 (»slave«).

TOUCH EM25 is microprocessor controlled electronic light dimmer. It serves as switch and dimmer for dimmable and some of no-dimmable lamps. Integrated microprocessor automatically identifies the type of lamp and adjusts the operating mode. It remembers the level of dimming after switching off due to integrated memory function. Soft-start function extends the lamp service life. In button integrated elegant LED illumination enables many different colors and intensity levels. Optionally one can connect of up to 5 additional control tasters EM26 ("slave").

SWITCH / DIMMER UNIVERSAL RLC 0-300W 2M

- universal electronic dimmer for ON/OFF switching and dimming of all dimmable lamps (classical, halogen, LED, CFL, ...) and some no-dimmable lamps
- automatic detection of lamp type and adjustment of operating mode
- reduction of energy consumption
- soft start function extends life of lamps
- controlled by build-in micro switches
- memory function included – memorizes brightness on turn-off
- up to five (5) additional control units EM26 can be connected
- connection with 2-way switch is not possible
- build-in short-circuit, overheating and overload protection
- supply voltage 230V~ 50Hz
- elegant LED illumination, adjustable colour and brightness
- replacement of classical switch is possible at two-wire connection⁽¹⁾
- full functionality is achieved at three-wire connection⁽²⁾
- in accordance with EN 60669-1 and EN 60669-2-1
- screw contacts 1.5mm² (max. tightening torque 0.4Nm)

⁽¹⁾dvožična vezava
two-wire connection

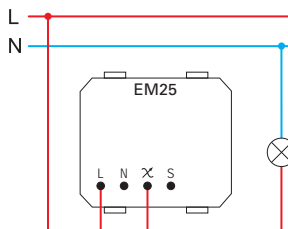

- dvožična vezava omogoča zatemnjevanje zatemnilnih žarnic in sijalk

- two-wire connection allows dimming of dimmable lamps

⁽²⁾trožična vezava
three-wire connection

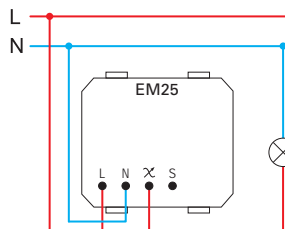

- trožična vezava omogoča zatemnjevanje zatemnilnih žarnic in sijalk in nekaterih nezatemnilnih LED in CFL sijalk

- three-wire connection allows dimming of dimmable lamps and some of no-dimmable LED and CFL lamps

	1	2	5	6	7
Min.	40 W	40 W	40 VA	40 VA	40 VA
Max.	300 W	300 W	300 VA	100 VA	100 VA
	Ⓢ	Ⓢ	Ⓢ		

- 1 - žarnica z žarilno nitko / incandescent lamp
- 2 - halogenska žarnica / halogen lamp

- 4 - elektronski transformator / electronic transformer
- 5 - klasični transformator / classical transformer

	1	2	4	6	7	8	9
Min.	0 W	0 W	0 VA	0 VA	0 VA	0 VA	0 VA
Max.	300 W	300 W	120 VA	120 VA	120 VA	120 VA	120 VA
	Ⓢ	Ⓢ	Ⓢ			Ⓢ	Ⓢ

- 6 - zatemnilna varčna CFL sijalka / dimmable energy saving CFL lamp

- 7 - zatemnilna LED sijalka / dimmable LED lamp

- 8 - nezatemnilna varčna CFL sijalka / no-dimmable energy saving CFL lamp

- 9 - nezatemnilna LED sijalka / no-dimmable LED lamp

opombe / remarks

- Ⓢ filter EM27
- priporočamo uporabo filtra EM27 / it is recommended to use filter EM27
- vse krmiljene žarnice in sijalke morajo biti enake / all controlled lamps must be the same
- tabela bremen velja za sijalke s faktorjem PF>0.5 / table of loads is valid for lamps with power factor PF>0.5

vklop in izklop ter zatemnjevanje luči /
on / off swithcing and dimming of lamp

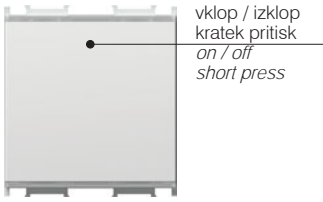

vklop / izklop
kratek pritisk
on / off
short press



osvetljevanje
daljši pritisk
dimming up
long press

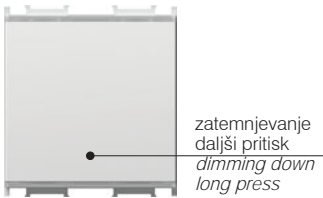

zatemnjevanje
daljši pritisk
dimming down
long press

izbira barve in nastavev jakosti LED osvetlitve /
LED colour selection and intensity level adjustment



izklop luči
kratek pritisk
lamp off
short press



hkratni pritisk ~3s
vgrajena lučka 3x utripne
simultaneous press ~3s
integrated LED blinks 3 times



izbira barve
kratek pritisk
colour selection
short press



osvetljevanje vgrajene LED
daljši pritisk
integrated LED dimming up
long press

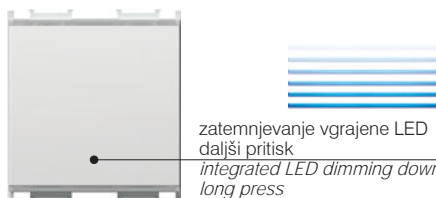

zatemnjevanje vgrajene LED
daljši pritisk
integrated LED dimming down
long press



shranitev nastavev - hkratni kratek pritisk
vgrajena lučka 3x utripne
settings saving - simultaneous short press
integrated LED blinks 3 times

funkcija "RESET" / "RESET" function *



izklop luči
kratek pritisk
lamp off
short press



hkratni pritisk ~3s
vgrajena lučka 3x utripne
simultaneous press ~3s
integrated LED blinks 3 times



ponovni hkratni pritisk ~5s
vgrajena lučka 5x utripne
re-simultaneous press ~5s
integrated LED blinks 5 times

- * - priporočamo ob vgraditvi zatemnilnika in menjavi žarnic ali sijalk
- obvezno ob uporabi nezatemnilnih sijalk
- funkcija "RESET" pri uporabi dvožične vezave ne deluje
- možno samo pri EM25
- it is recommended at dimmer installation and lamp replacement
- mandatory when using no-dimmable lamps
- "RESET" function is not possible when using two-wire connection
- only possible on EM25

opozorila za vgradnjo / installation precautions

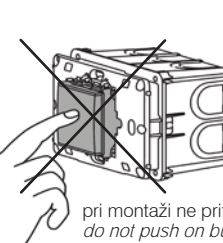
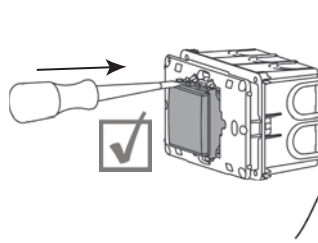
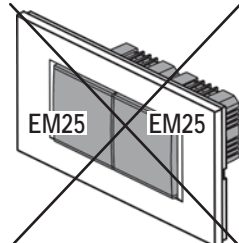
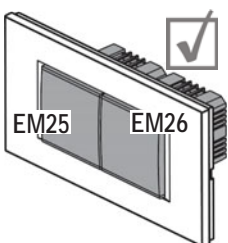

pri montaži ne pritiskaj na tipko /
do not push on button during mounting

TIPKALO UPRAVLJALNO 2M

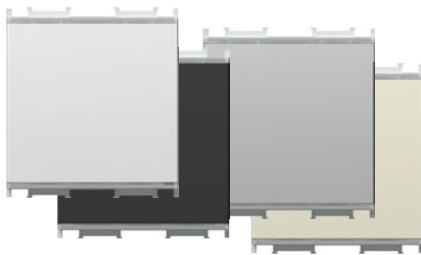

- EM26PW
- EM26SB
- EM26ES
- EM26IW

- v povezavi z univerzalnim zatemnilnikom EM25 omogoča upravljanje luči z več (do pet) lokacij z enako funkcionalnostjo kot EM25
- napajanje 230V ~ 50Hz
- ustreza EN 60669-1 in EN 60669-2-1
- vijajčna pritrditev vodnikov 1.5mm² (maks. moment pritvitja vijakov 0,4 Nm)



PUSH-BUTTON CONTROL UNIT 2M

- connected to universal dimmer EM25 allows controlling of lamps with same functionality as EM25
- supply voltage 230V ~ 50Hz
- in accordance with EN 60669-1 and EN 60669-2-1
- screw contacts 1.5mm² (max. tightening torque 0.4Nm)

(1) dvožična vezava
two-wire connection

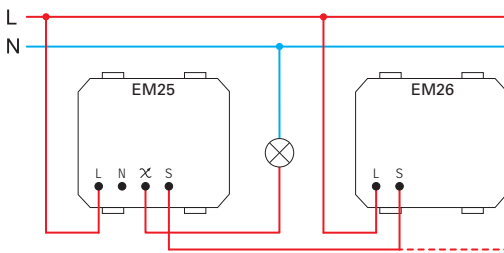

- dvožična vezava omogoča zatemnjevanje zatemnilnih žarnic in sijalk
- pri dvožični vezavi uporaba vsakega dodatnega upravljalnega tipkala poveča minimalno moč bremena za 25W
- two-wire connection allows dimming of dimmable lamps
- in a two-wire connection each additional control unit increases the minimum load by 25W

(2) trožična vezava
three-wire connection

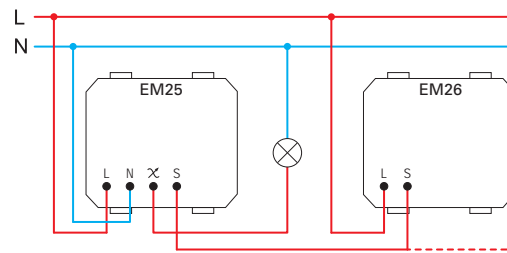

- trožična vezava omogoča zatemnjevanje zatemnilnih žarnic in sijalk in nekaterih nezatemnilnih LED in CFL sijalk
- three-wire connection allows dimming of dimmable lamps and some of non-dimmable LED and CFL lamps

FILTER OMREŽNIH MOTENJ



- EM27

- filter frekvenčnih motenj za EM25
- slika je simbolična
- FREQUENCY FILTER**
- frequency filter for EM25
- image is symbolic

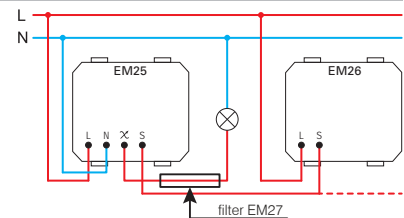

SET STIKALO / ZATEMNILNIK UNIVERZALNI RLC 0-300W 2M PP OL20



- EM25PPOL20

- set vsebuje zatemnilnik EM25, nosilec 2M in okvir LINE 2M PW
- za tehnični opis glej EM25
- SET SWITCH / DIMMER UNIVERSAL RLC 0-300W 2M PP OL20**
- set includes dimmer EM25, mounting frame 2M and cover plate LINE 2M PW
- for technical details see EM25



2M = 45 x 45

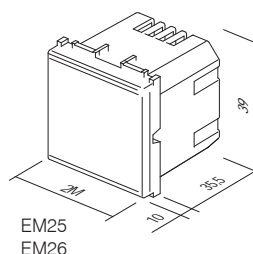

EM25
EM26



- EM31PW
- EM31SB
- EM31ES
- EM31IW

IR STIKALO 5A 250V~ 1M

- IR infrardeče stikalo
- napajanje: 230V~ ± 10 % 50Hz
- rele: 5A / 250V~ izhod za omejen tok z visokim uporom za zero crossing
- stopnja varnosti: IP40
- presek žic pri stičniku: 0,75 - 2,5 mm²
- kot zaznavanja: do 110° pri 20°C
- območje zaznavanja: približno 8 m pri 20°C
- nastavljivost časovnega trajanja: od približno 5 s do 12 min
- nastavljivost osvetlitve: od približno 5 do 200 LUX
- temperatura delovanja: od 0°C do +40°C
- ni primeren za vgradnjo v doze, globine 45 mm in ohišja CUBO IP20
- samo za notranjo uporabo



IR SWITCH 5A 250V~ 1M

- IR infrared switch
- supply voltage: 230V~ ± 10 % 50Hz
- relay: 5A / 250V~ output for limited current with high resistance for zero crossing
- protection rating: IP40
- cross-section of wires at the contact terminal: 0.75 - 2.5 mm²
- detection angle: up to 110° at 20°C
- detection area: approx. 8 m at 20°C
- adjustability of duration: from approx. 5 s to 12 min
- adjustability of brightness: from approx. 5 to 200 LUX
- operating temperature: from 0°C to +40°C
- not suitable for installation in 45 mm deep boxes and surface mount box CUBO IP20
- only for indoor usage



- EM32PW
- EM32SB
- EM32ES
- EM231W

IR STIKALO 5A 250V~ 2M

- IR infrardeče stikalo
- napajanje: 230V~ ± 10 % 50Hz
- rele: 5A / 250V~ izhod za omejen tok z visokim uporom za zero crossing
- stopnja varnosti: IP40
- presek žic pri stičniku: 0,75 - 2,5 mm²
- kot zaznavanja: do 110° pri 20°C
- območje zaznavanja: približno 8 m pri 20°C
- nastavljivost časovnega trajanja: od približno 5 s do 12 min
- nastavljivost osvetlitve: od približno 5 do 200 LUX
- temperatura delovanja: od 0°C do +40°C
- ni primeren za vgradnjo v doze, globine 45 mm in ohišja CUBO IP20
- samo za notranjo uporabo



IR SWITCH 5A 250V~ 2M

- IR infrared switch
- supply voltage: 230V~ ± 10 % 50Hz
- relay: 5A / 250V~ output for limited current with high resistance for zero crossing
- protection rating: IP40
- cross-section of wires at the contact terminal: 0.75 - 2.5 mm²
- detection angle: up to 110° at 20°C
- detection area: approx. 8 m at 20°C
- adjustability of duration: from approx. 5 s to 12 min
- adjustability of brightness: from approx. 5 to 200 LUX
- operating temperature: from 0°C to +40°C
- not suitable for installation in 45 mm deep boxes and surface mount box CUBO IP20
- only for indoor usage

območje zaznavanja / detection range

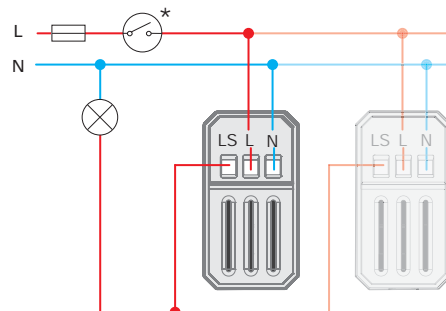
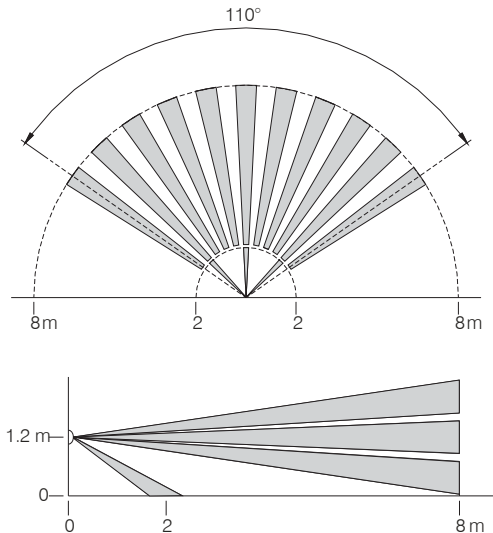

nastavitev občutljivosti in časa osvetlitve / *time and twilight adjustment*

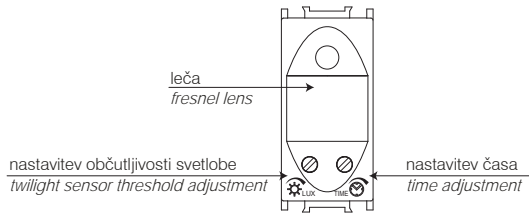

5 LUX	200 LUX	
	~5 s	~12 min

bremena / *loads*

	1	2	3	4	5	6	7	8
Min. Max.	1 W 800 W	1 W 800 W	5A	1 VA 6x20 VA	1 W 6x36 W	1 W 4x36 W (20µF)	1 VA 6x23 VA	1 VA 6x20 VA

- 1 - žarnica z žarilno nitko / *incandescent lamp*
- 2 - halogenska žarnica / *halogen lamp*
- 3 - uporovno grelna telo / *resistive heating element*
- 4 - elektronski transformator / *electronic transformer*
- 5 - fluorescentna cev (izvedba 1) / *fluorescent tube (version 1)*
- 6 - fluorescentna cev (izvedba 2) / *fluorescent tube (version 2)*
- 7 - varčna CFL sijalka / *energy saving CFL lamp*
- 8 - LED sijalka / *LED lamp*

opozorila / *attention*

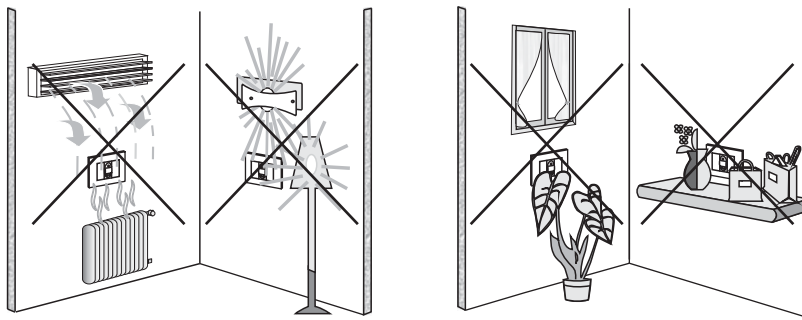

1M = 22,5 x 45

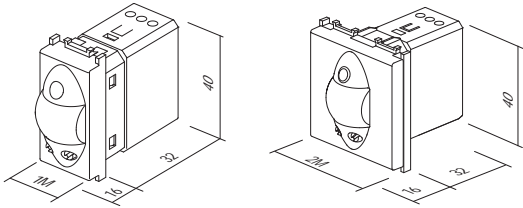



- EM37PW
- EM37SB
- EM37ES
- EM37IW

TERMOSTAT OSNOVNI 6A 230V~ 2M

- termostat elektronski osnovni
- način delovanja: ogrevanje / hlajenje / izklop
- napajanje: 230 VAC, 50 Hz
- izhod: 6(2) A, 230 VAC, preklopni rele
- območje regulacije: +10 °C do +30 °C
- histereza: ±0,5 °C, ED = 20min
- zaščita proti zmrzovanju (način ogrevanja): +6 °C
- zaščita proti pregrevanju (način hlajenje): +32 °C
- funkcija ECO za znižanje temperature za 3 °C za 6 ur v načinu ogrevanje in povečanje temperature za 3 °C za 6 ur v načinu hlajenje
- funkcija adaptivni ECO, avtomatsko vsak dan ob istem času zniža temperaturo za 3 °C za 6 ur v načinu ogrevanje in poveča temperaturo za 3 °C za 6 ur v načinu hlajenje
- možnost vklopa ECO režima delovanja z zunanjim proženjem preko ločenega vhoda
- LED indikacija delovanja
- ni primeren za električno talno ogrevanje
- vijčna pritrditev vodnikov max. 2,5 mm²
- ustreza LV Direktivi, EMC direktivi, standardi EN60730-1 in EN60730-2-9
- za pravilno delovanje, priporočamo vgradnjo v samostojno dozo, ločeno od naprav, ki generirajo toploto
- temperatura uporabe: 5 ÷ 35 °C
- temperatura skladiščenja: -20 ÷ 50 °C



Termostat je namenjen reguliranju temperature v prostoru. Termostat omogoča dva načina delovanja – ogrevanje ali hlajenje. Vgrajene ima varovalne funkcije zaščito proti zmrzovanju (način ogrevanja) in zaščito proti pregrevanju (način hlajenja). Delovanje se signalizira s pomočjo LED lučk. Nastavljanje termostata se vrši s pomočjo rotacijskega gumba za nastavitve temperature in kapacitivnih tipk na dotik.

The thermostat is intended for regulating temperature in a room. A thermostat enables two modes of operation – heating or cooling. It has safety functions installed for protection against freezing (heating mode) and protection against overheating (cooling mode). The operation is indicated via LED lights. Thermostat setup is performed with the help of a rotary button for setting the temperature and with other capacitive touch buttons.

THERMOSTAT BASIC 6A 230 V ~ 2M

- electronic thermostat, basic
- operation mode: heating/cooling/turn off
- power supply: 230 VAC, 50 Hz
- output: 6(2) A, 230 VAC, relay switch
- regulation range: +10 °C to +30 °C
- hysteresis: ±0.5 °C, ED = 20min
- anti-freeze protection (heating mode): +6 °C
- overheating protection (cooling mode): +32 °C
- ECO function for lowering the temperature by 3 °C for 6 hours in the heating mode and raising temperature by 3 °C for 6 hours in the cooling mode
- adaptive ECO function, automatically every day at the same time lowers the temperature by 3 °C for 6 hours in the heating mode and raises temperature by 3 °C for 6 hours in the cooling mode
- option to turn on the ECO operating mode by external trigger via a separate input
- LED indication of operation
- not suitable for electrical floor heating
- screw contacts max. 2.5 mm²
- in accordance with the LV Directive, the EMC Directive, standards EN60730-1 and EN60730-2-9
- for correct operation, we recommend installing in an independent single box, separate from devices that generate heat
- operating temperature: 5 ÷ 35 °C
- storage temperature: -20 ÷ 50 °C

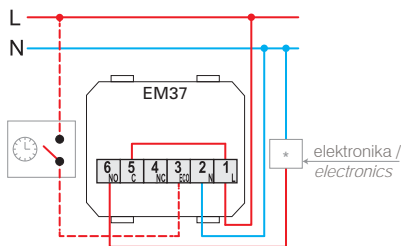

obtočna črpalka, gorilnik (direktna priključitev), termoelektrični pogon / circulation pump, burner (direct connection) thermoelectric drive

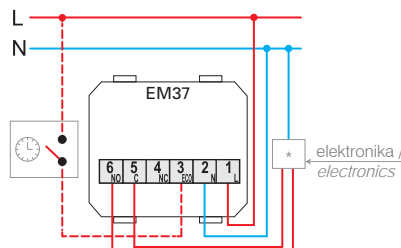

kotel, toplotna črpalka, gorilnik (krmilni vhod T1/T2) / boiler, heat pump, burner (control input T1/T2)

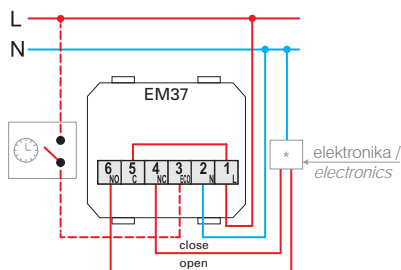

motorni pogon (omejena uporaba pri talnem ogrevanju) / motor drive (limited use with underfloor heating)

nastavitev delovanja in temperature / function and temperature adjustment

tipka za izbiro delovanja in LED indikator stanja:
 rdeča: ogrevanje
 modra: hlajenje
 ne sveti: izklopljeno

function selection button and LED status indicator:
 red: heating
 blue: air conditioning
 no light: switched off

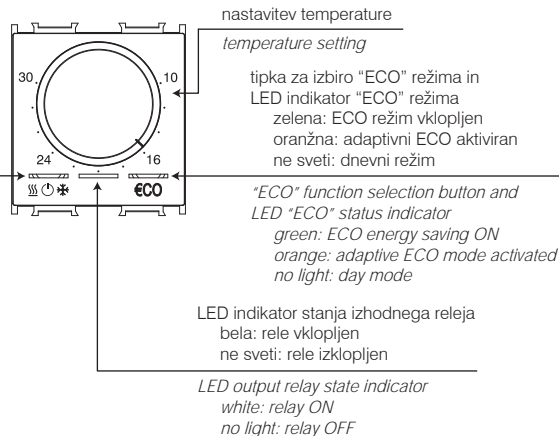

opozorila / attention

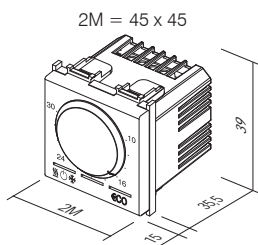
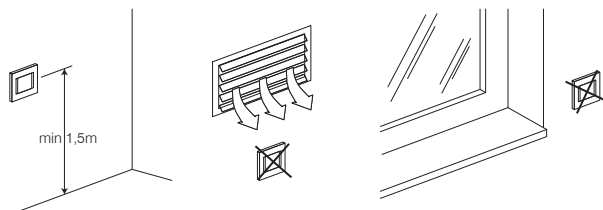

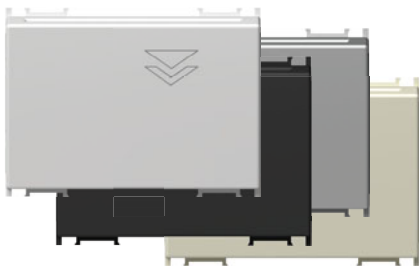

- EM40PW
- EM40SB
- EM40ES
- EM40IW

KARTIČNO STIKALO ZA VARČEVANJE Z ENERGIJO 3A 250V~ 3M

- kartično stikalo osnovno, poljubna ISO kartica
- napajanje 230V~ 50Hz
- izhod 3A 250V~ za vklop zunanjega kontaktorja *
- zakasnitev izklopa 15-20s
- ustreza EN 61000-6-1
- kartica ni priložena
- ni namenjeno kontroli pristopa



ENERGY SAVER CARD SWITCH 3A 250V~ 3M

- card switch basic, any ISO card
- supply voltage 230V~ 50Hz
- output 3A 250V~ for switching contactor *
- switch off delay 15-20s
- in accordance with EN 61000-6-1
- card is not included
- not for access control

3M = 67,5 x 45

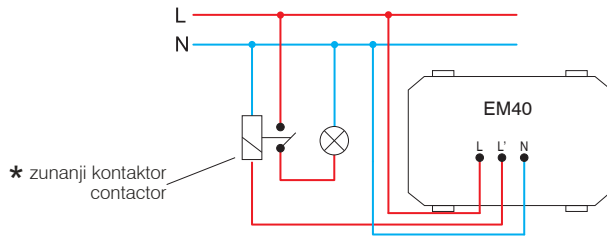
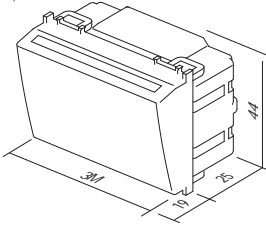

* zunanji kontaktor
contactor

KARTICA ISO

EM47

- ISO kartica
- za uporabo s kartičnim stikalom EM40
- velikost: 85x54 mm

CARD ISO

- ISO card
- for combination with card switch EM40
- size: 85x54 mm





EM44BK

KARTIČNO STIKALO ZA VARČEVANJE Z ENERGIJO RF HF 13,56MHz 3M

- kartično stikalo elektronsko na RFID ISO kartico
- napajanje iz rele enote EM49 preko kabla s konektorji RJ12
- izhod za povezavo za rele enoto EM49
- zakasnitev izklopa "main power" ob izvlečenju kartice 15-20 s
- zakasnitev izklopa "HVAC" ob izvlečenju kartice pri odprtih balkonskih vratih ali oknu - 1 min
- ustreza EN 61000-6-1
- kartica ni priložena
- ni namenjeno kontroli pristopa

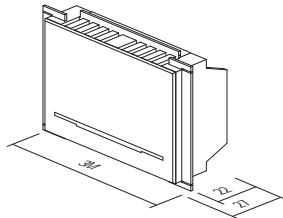

ENERGY SAVER CARD SWITCH RF HF 13,56MHz 3M

- electronic card switch for RFID ISO card
- supply from relay unit EM49 through cable connectors RJ12
- output to be connected to relay output unit EM49
- 15-20s "main power" switch off delay with card withdrawal
- 1 min "HVAC" switch off delay with card withdrawal when balcony doors or windows opened
- in accordance with EN 61000-6-1
- card is not included
- not for access control



EM49

RELE ENOTA ZA KARTIČNO STIKALO 2X16A 250V~

- rele enota za kartična stikala EM44
- napajanje 230V~ 50 Hz
- ustreza EN 61000-6-1
- montaža na DIN letev 35mm, 3MU
- vhodi in izhodi glede na vgradnjo: enosobno ali dvosobno

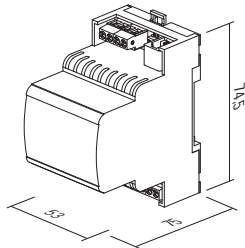

ENERGY SAVER CONTROL UNIT 2x16A 250V~

- relay unit for card switches EM44
- supply voltage 230V~ 50Hz
- in accordance with EN 61000-6-1
- mounting on DIN rail 35mm, 3MU
- input and output depending on implementation: single or double room



EM45

RAZDELILNIK SPL-1

- za povezavo dveh kartičnih stikal EM44 z rele enoto EM49
- komunikacijski konektor RJ12
- velikost: 37 x 30 x 27 mm

SPLITTER SPL-1

- used to connect two peripheral modules EM44 to relay unit EM49
- communication connector RJ12
- size: 37 x 30 x 27 mm

vezalna shema za enosobno delovanje / wiring diagram for single room implementation

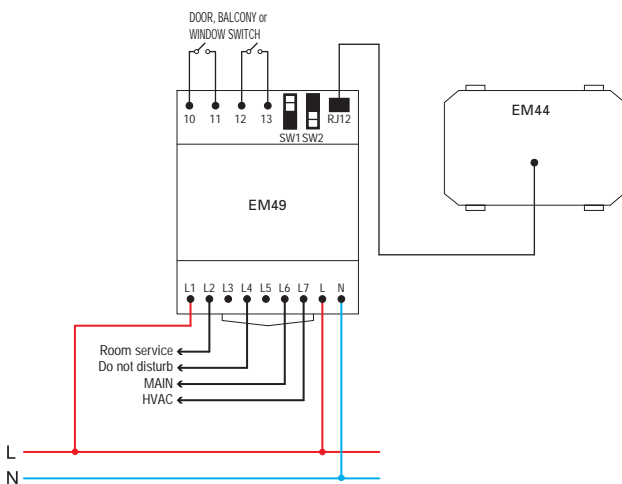

vezalna shema za dvosobno delovanje / wiring diagram for double room implementation

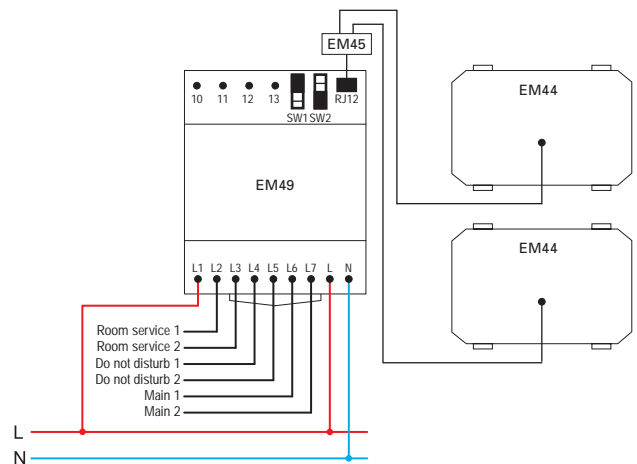

povezovalni kabel RJ12 med EM44 in EM49 / connection cable RJ12 between EM44 and EM49

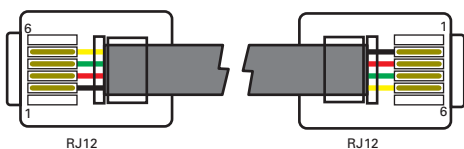



- EM60PW
- EM60SB
- EM60ES
- EM60IW

VTIČNICA ZA BRIVNIK 230V~/125V~ 3M

- vtičnica za brivnik z ločilnim transformatorjem 20VA
- vhod: 230V~ 50-60Hz
- izhod:
- 230V~ za 2P 2.5A EURO vtič ali
- 125V~ za 2P 15A ameriški vtič
- razred zaščite II
- ustreza EN 61558-2-5



SOCKET SHAVER 230V~/125V~ 3M

- shaver supply unit with isolating transformer 20VA
- supply: 230V~ 50-60Hz
- output:
- 230V~ for 2P 2.5A Europlug or
- 125V~ for 2P 15A American plug
- Class II
- in accordance with EN 61558-2-5

3M = 67,5 x 45

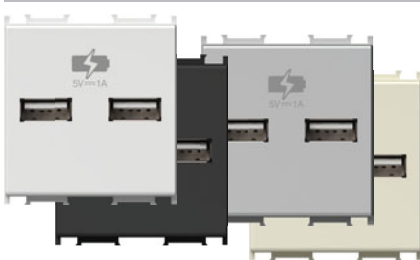
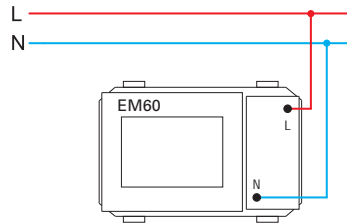
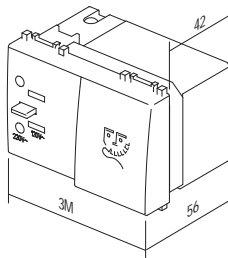

- EM65PW
- EM65SB
- EM65ES
- EM65IW

POLNILNIK USB 5V 1A 2M

- za polnjenje elektronskih naprav preko standardnega USB priključka (kompatibilno tudi z Apple napravami)
- omogoča hkratno polnjenje dveh naprav
- napajanje: 230V~ 50Hz
- poraba v mirovanju: 50 mW pri 230V~
- izhodna napetost: 5 VDC (±5%) SELV
- nihanje izhodne napetosti: 150 mV
- nominalni izhodni tok: 1 A (1 x 1.000 mA ali 2 x 500 mA) (±10%)
- učinkovitost: več kot 67%
- IP zaščitni razred: IP20, samo za notranjo uporabo
- vijačna pritrditev vodnikov max. 2.5 mm²
- ustreza standardom EN 60950-1 in EMC direktivi
- polnilnik mora biti varovan z ustreznim zunanjim odklopnikom



2M = 45 x 45

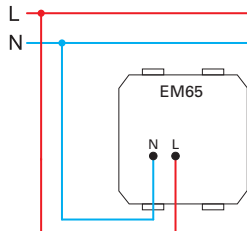
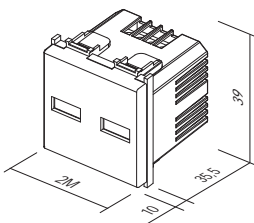

POWER SUPPLY UNIT USB 5V 1A 2M

- for charging of electronic devices via a standard USB port (also compatible with Apple devices)
- enables charging of two devices simultaneously
- power supply: 230V~ 50Hz
- stand-by power consumption: 50 mW pri 230V~
- nominal output voltage: 5 VDC (±5%) SELV
- output ripple voltage: 150 mV
- nominal output current: 1 A (1 x 1.000 mA or 2 x 500 mA) (±10%)
- efficiency: greater than 67%
- IP protection class: IP20, indoor use only
- screw contacts: max. 2.5 mm²
- in accordance with EN 60950-1 and EMC directive
- an appropriate external disconnect device needs to be considered as part of installation



- EM55

LED ZASILNA SVETILKA 250V~ 1.5W, NiMh 6h 7M

- zasilna LED svetilka
- napajanje 230V~ 50Hz 3x0.5W LED sijalke E10, zamenljive
- NiMh akumulator 1150 mAh, zamenljiv
- avtonomija 6h, polnjenje 4h
- razred zaščite II
- ustreza EN 60598-1, EN 60598-2-2, EN 60598-2-22
- svetilnost 76lx / 0,9m²



LED EMERGENCY LIGHT 250V~ 1.5W, Ni-Mh 6h 7M

- emergency LED lamp
- supply voltage 230V~ 50Hz 3x0.5W LED lamps E10, replaceable
- NiMh accumulator 1150 mAh, replaceable
- autonomy 6h, charging 4h
- Class II
- in accordance with EN 60598-1, EN 60598-2-2, EN 60598-2-22
- illumination 76lx / 0,9m²

7M = 151,5 x 45

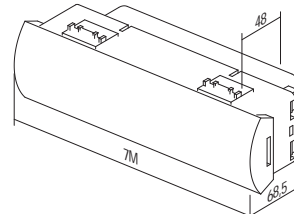
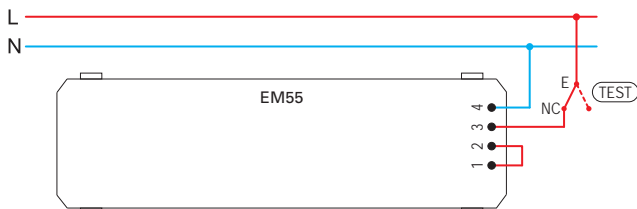

SVETILKA LED ENOBARVNA 250V~ 0,8W 2M

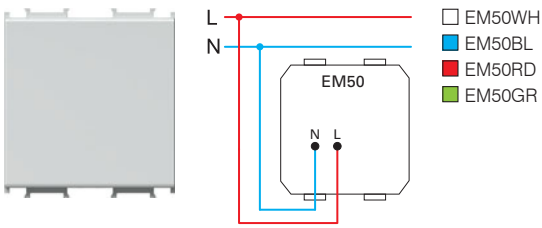

- LED svetilka za osvetlitev stopnišč ali hodnikov
- napajanje 230V~ 50Hz 0,8W
- razred zaščite II
- ustreza EN 60598-1
- uporaba tudi za usmerjanje ali signalizacijo z možnostjo laserskega tiska poljubne grafike

LED LAMP MONOCOLOR 250V~ 0,8W 2M

- step marker LED lamp
- supply voltage 230V~ 50Hz 0,8W
- Class II
- in accordance with EN 60598-1
- optional usage for directional or signal illumination with customized laser printing on diffuser



SVETILKA LED DVOBARVNA 250V~ 2x0,4W 2M

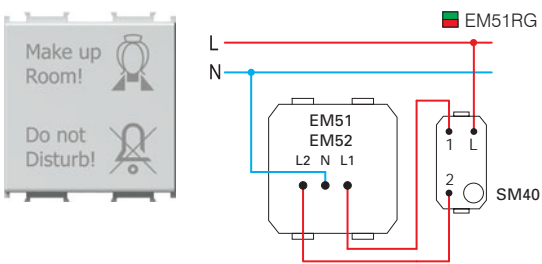

- LED dvoobarvna svetilka (rdeča/zelena) za signalizacijo
- napajanje 230V~ 50Hz 2x0,4W
- razred zaščite II
- ustreza EN 60598-1
- vsebuje grafiko kot na sliki
- možnost laserskega tiska poljubne grafike

LED LAMP DUAL COLOR 250V~ 2x0,4W 2M

- signalling dual color (red/green) LED lamp
- supply voltage 230V~ 50Hz 2x0,4W
- Class II
- in accordance with EN 60598-1
- diffuser includes graphics as shown
- possible customized laser printing on diffuser



SVETILKA LED 3D DVOBARVNA 250V~ 2x0,4W 2M

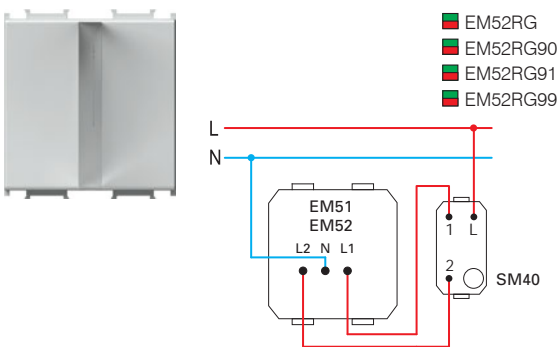

- LED dvoobarvna svetilka (rdeče/zelena) s 3D simbolom, za signalizacijo
- napajanje 230V~ 50Hz 2x0,4 W
- razred zaščite II
- ustreza EN 60598-1
- možnost tiska različnih grafik po naročilu
- 90 moški simbol, 91 ženski simbol, 99 simbol po naročilu

LED LAMP 3D DUAL COLOR 250V~ 2x0,4W 2M

- signalling LED lamp, dual color (red/green) with 3D symbol
- supply voltage 230V~ 50Hz 2x0,4W
- class II
- in accordance with EN 60598-1
- possible customized graphics on request
- 90 male symbol, 91 female symbol, 99 symbol on request

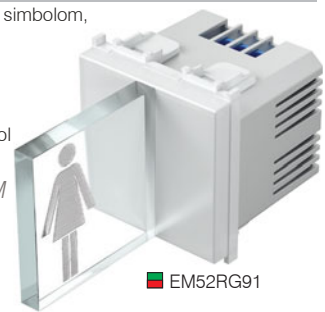

2M = 45 x 45

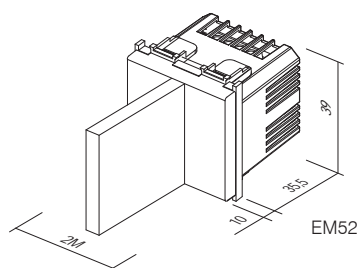
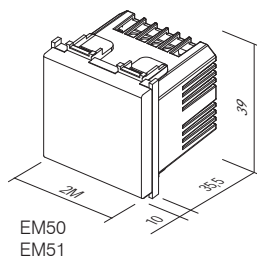

STIKALO NA PRSTNI ODTIS ARX ONE 2M



- EM70PW
- EM70SB
- EM70ES
- EM70IW

- stikalo na prstni odtis v kompletu z notranjo rele enoto
- za odklepanje električnih ključavnic
- kapaciteta 1000 odtisov
- enostavno programiranje z dvema tipkama
- termalni biometrični senzor
- napajanje notranje rele enote 110-230V~ 50-60Hz
- izhodni rele 2x3A 12V DC
- 256-bitna enkripcija povezave med stikalom in notranjo rele enoto
- ustreza EN 61000-6-1



FINGERPRINT SWITCH ARX ONE 2M

- fingerprint switch with included internal relay unit
- for unlocking electrical locks
- capacity 1000 fingerprints
- easy programming with two buttons
- thermal biometric sensor
- internal relay unit supply 110-230V~ 50-60Hz
- output relay 2x3A 12V DC
- 256-bit encrypted link between switch and internal relay unit
- in accordance with EN 61000-6-1

VNOS UPRAVNIKA

1. Prvi trije odtisi imajo upravniske pravice.
2. Postopek vnosa je enak kot pri dodajanju uporabnika, le brez drugega koraka.

ADMINISTRATOR ENROLMENT

1. The first three fingerprints enrolled are assigned administrative rights.
2. Administrator enrolment procedure is same as user enrolment without second step.

DODAJANJE UPORABNIKA

1. Na zunanji enoti držimo levo tipko 3 sekunde. Oranžna dioda začne počasi utripati.
2. Upravnik s prstom enkrat potegne po senzorju. Oranžna dioda začne hitro utripati.
3. Pritisnemo levo tipko. Za potrditev se prižge zelena dioda in pisk za 1 s.
4. Oranžna in zelena dioda izmenično utripata. Sedaj prst po senzorju štirikrat potegne uporabnik. Vsak vnos spremlja pisk.
5. Ko je uporabniški odtis uspešno vnešen, zasveti zelena dioda, zasliši se pisk.

USER ENROLMENT

1. The left button on the exterior unit is pressed for 3 seconds. The orange LED starts flashing slow.
2. An administrator swipes his finger over the sensor once. When he/she is identified, the orange LED will start flashing fast.
3. Press left button. The green LED confirms.
4. The orange and green LED will flash alternately. At this point the user swipes his/her finger over the sensor four times. Each successful entry is indicated by a buzz.
5. When the user is correctly enrolled, the green LED will flash and the buzzer will buzz at the same time.

BRISANJE UPORABNIKA

1. Na zunanji enoti držimo desno tipko 5 sekund. Oranžna dioda začne počasi utripati.
2. Upravnik s prstom enkrat potegne po senzorju. Uspešna identifikacija je potrjena, ko zasveti zelena dioda in se zasliši pisk.
3. Rdeča in zelena dioda izmenično utripata. Prst po senzorju enkrat potegne uporabnik, ki ga želimo zbrisati. Ko je pozitivno identificiran, zasveti zelena dioda in pisk za 1 s. Uporabnik je uspešno izbrisan.

DELETING A USER

1. The right button on the exterior unit should be pressed for 5 seconds whereupon the orange LED will start flashing slow.
2. An administrator swipes his finger over the sensor once. When he/she is identified, the green LED will flash and the buzzer will buzz at the same time.
3. The red and green LED will flash alternately. Then the user swipes his finger over the sensor once. When the user is identified, the green LED flash and the buzzer will buzz once. The user has been successfully deleted from the system.

BRISANJE VSEH ODTISOV

1. Na zunanji enoti držimo obe tipki skupaj 10 sekund. Oranžna in rdeča dioda začneta izmenično utripati.
2. Upravnik s prstom enkrat potegne po senzorju. Uspešna identifikacija je potrjena, ko zasveti zelena dioda in se zasliši pisk.
3. Oranžna in rdeča dioda zopet izmenično utripata. Upravnik ponovi 2. korak.
4. Po kratkem premoru rdeča in oranžna dioda skupaj petkrat zasvetita, naprava pa petkrat zapiska v enakem intervalu. Vsi odtisi so bili uspešno zbrisani iz baze podatkov.

DELETING ALL FINGERPRINTS

1. Press the left and right button on the exterior unit together for a period of 10 seconds whereupon the orange and red LED will flash alternately.
2. The administrator then swipes his/her finger once. Identification is confirmed when the green LED flashes and the buzzer buzzes at the same time.
3. The orange and red LED will flash alternately again. The administrator repeats second step.
4. The red and orange LED will flash and the buzzer will buzz five times simultaneously. All fingerprint templates will then have been deleted.

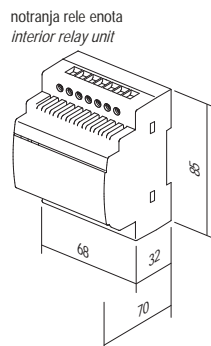
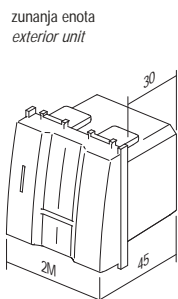
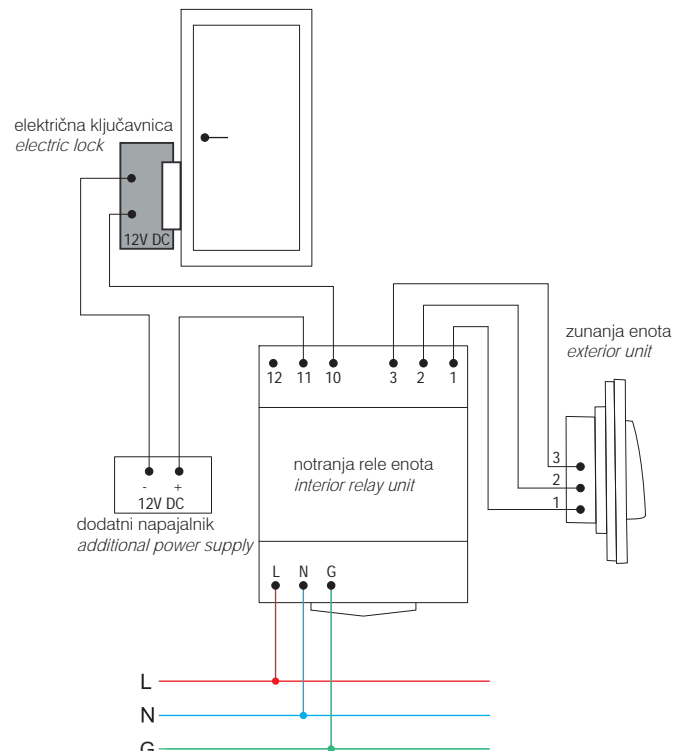
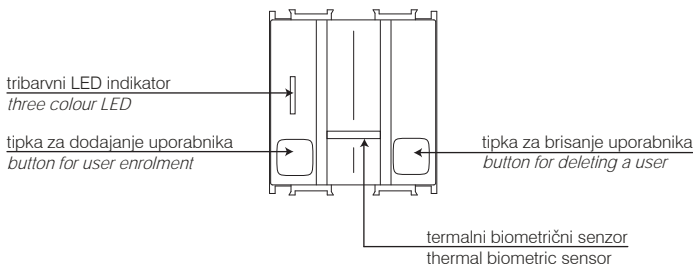
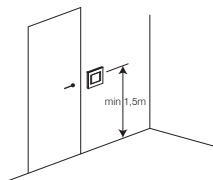

STIKALO BREZDOTIČNO 10A 240V~



□ EM80GW

- stikalo brezdotično za vklop in izklop ("master")
- napajanje: 240 V~ 50 Hz
- izhodni rele 10A / 250V~ (2400W pri 240V~)
- nastavljiv domet od 2 do 10 cm
- namenjeno za montažo v standardne okrogle doze Ø60 mm
- za priklop je nujen ničelni vodnik (N)
- vezava z menjalnimi stikali ni možna
- možna vezava do 5 upravljalnih stikal EM81
- enostavna montaža dekorativnih okvirjev s pomočjo magnetov
- vijačna pritrditev vodnikov do 2,5 mm² (maks. moment privitja vijakov 0,4 Nm)
- ustreza EN 60669-1 in EN 60669-2-1
- samo za notranjo uporabo



SWITCH, TOUCHLESS 10A 240V~

- touchless switch for turning on/off ("master")
- power supply: 240 V~ 50 Hz
- output relay 10A / 250V~ (2400W at 240V~)
- adjustable range from 2 to 10 cm
- intended for installation into a standard round Ø60 mm box
- a neutral lead (N) is required for connection
- connection with toggle switches is not possible
- connection with up to 5 EM81 control switches is possible
- simple installation of decorative covers with the help of magnets
- screw fastening of leads up to 2.5 mm² (max. screw tightening torque is 0.4 Nm)
- in accordance with EN 60669-1 and EN 60669-2-1
- only for indoor use

STIKALO BREZDOTIČNO UPRAVLJALNO



□ EM81GW

- stikalo upravljalno («slave»)
- deluje samo v povezavi s stikalom EM80 ("master")
- enostavna montaža dekorativnih okvirjev s pomočjo magnetov
- vijačna pritrditev vodnikov do 2,5 mm² (maks. moment privitja vijakov 0,4 Nm)
- ustreza EN 60669-1 in EN 60669-2-1
- samo za notranjo uporabo



SWITCH, TOUCHLESS, CONTROL UNIT

- control switch ("slave")
- works only when connected with the EM80 switch ("master")
- simple installation of decorative covers with the help of magnets
- screw fastening of leads up to 2.5 mm² (max. screw tightening torque is 0.4 Nm)
- in accordance with EN 60669-1 and EN 60669-2-1
- only for indoor use

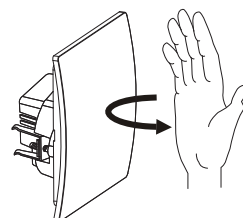
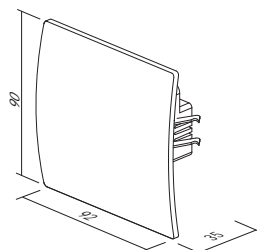
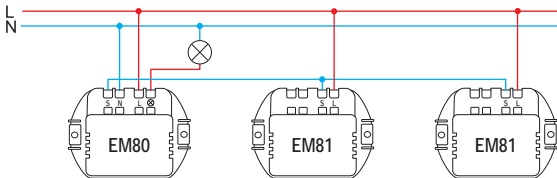
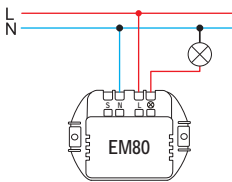

BRENČAČ 8VA 230V~ 1M

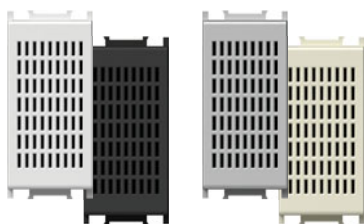

- EM90PW
- EM90SB
- EM90ES
- EM90IW

- signalni brenčač
- dolžina zvoka je enaka dolžini pritiska na tipko
- napajanje 230V~ 50Hz 8VA

BUZZER 8VA 230V~ 1M

- signal buzzer
- the sound emission has the same lasting time as the control operation
- supply voltage 230V~ 50Hz 8VA



BRENČAČ 8VA 12V~ 1M

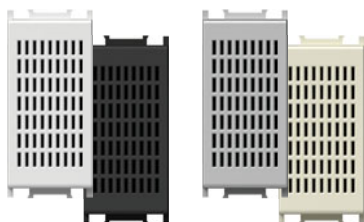

- EM91PW
- EM91SB
- EM91ES
- EM91IW

- signalni brenčač
- dolžina zvoka je enaka dolžini pritiska na tipko
- napajanje 12V~ 50Hz 8VA

BUZZER 8VA 12V~ 1M

- signal buzzer
- the sound emission has the same lasting time as the control operation
- supply voltage 12V~ 50Hz 8VA



ZVONEC 8VA 230V~ 1M

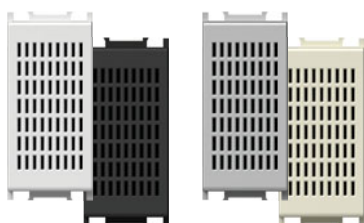

- EM92PW
- EM92SB
- EM92ES
- EM92IW

- signalni zvonec
- dolžina zvoka je enaka dolžini pritiska na tipko
- napajanje 230V~ 50Hz 8VA

BELL 8VA 230V~ 1M

- signal bell
- the sound emission has the same lasting time as the control operation
- supply voltage 230V~ 50Hz 8VA



ZVONEC 8VA 12V~ 1M

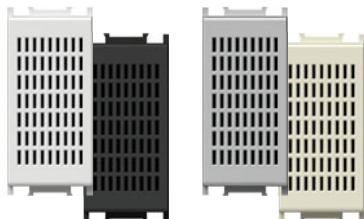

- EM93PW
- EM93SB
- EM93ES
- EM93IW

- signalni zvonec
- dolžina zvoka je enaka dolžini pritiska na tipko
- napajanje 12V~ 50Hz 8VA

BELL 8VA 12V~ 1M

- signal bell
- the sound emission has the same lasting time as the control operation
- supply voltage 12V~ 50Hz 8VA

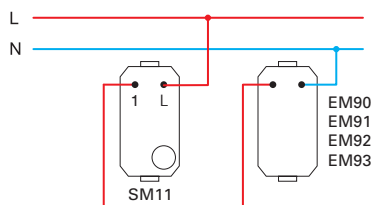
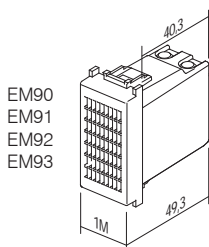

REGULATOR GLASNOSTI ZA 100V AVDIO LINIJO 35W 2M



- EM95PW
- EM95SB
- EM95ES
- EM95IW

- regulator glasnosti (atenuator) za 100V avdio sisteme
- nazivna moč 35W (max. 45W), 6 stopenjska nastavev glasnosti
- primeren za vgradnjo v globoke doze (min. 60 mm)
- ni primeren za vgradnjo v doze globine 45 mm in ohišja CUBO IP20
- samo za notranjo uporabo

VOLUME CONTROL 100V AUDIO LINE 35W 2M

- volume control (attenuator) for 100V audio systems
- power rating 35W (max. 45W), 6 steps volume control
- suitable for boxes min. 60 mm deep
- not suitable for installation in 45 mm deep boxes and surface mount boxes CUBO IP20
- for indoor use only

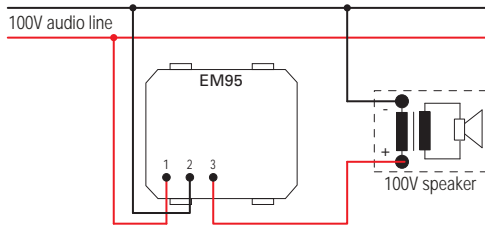

REGULATOR GLASNOSTI NIZKOOHMSKI 4-8 Ω 35W 2M



- EM96PW
- EM96SB
- EM96ES
- EM96IW

- regulator glasnosti za nizkonapetostne izhode 4-8 Ω 35W
- za priklon na HI-Fi naprave
- nazivna moč 35W, 6 stopenjska nastavev glasnosti
- primeren za vgradnjo v globoke doze (min. 60 mm)
- ni primeren za vgradnjo v doze globine 45 mm in ohišja CUBO IP20
- samo za notranjo uporabo

VOLUME CONTROL 4-8Ω 35W 2M

- volume control (attenuator) for low voltage outputs 4-8 Ω, 35W
- power rating 35W, 6 steps volume control
- suitable for boxes min. 60 mm deep
- not suitable for installation in 45 mm deep boxes and surface mount boxes CUBO IP20
- for indoor use only

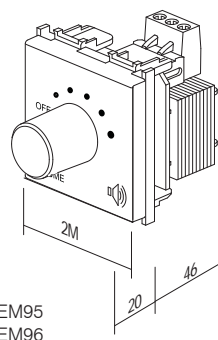
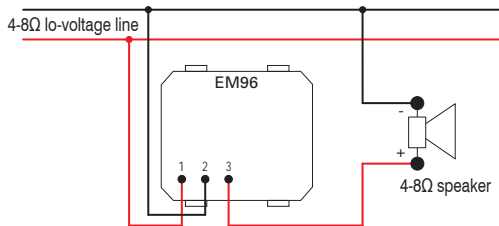

EM95
EM96



tip type	naziv description	tehnični opis technical data	velikost size	barva colour	opcijski opis 1 optional data 1
CM10	SET VTIČNIC 2x SCHUKO SOCKET SET 2x SCHUKO	2P+E 16A 250V~	4M	<input type="checkbox"/> PW bela-sijaj polar white	<input type="checkbox"/> OL okvir LINE cover plate LINE
CM11	SET VTIČNIC 3x SCHUKO SOCKET SET 3x SCHUKO	2P+E 16A 250V~	7M	<input type="checkbox"/> SB črna-mat soft touch black	<input type="checkbox"/> OS okvir SOFT cover plate SOFT
CM15	SET VEZNIKOV BARVNI LINK WIRE SET	3x1.5mm ²	1M	<input type="checkbox"/> ES srebrna-mat elox silver	
.	.	.	.	<input type="checkbox"/> IW bež-sijaj ivory white	

SET VTIČNIC 2x SCHUKO 2P+E 16A 250V~ 4M

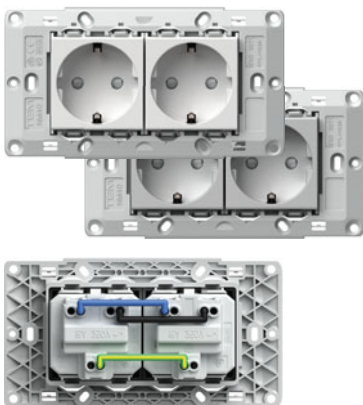

- CM10PW
- CM10ES

- set vtičnic 2x schuko VM10 2P+E 16A 250V~
- vtičnici povezani z vezniki CM16
- z nosilcem 4M brez vijakov
- za pritrnitev nosilcev uporabiti vijake CM17, CM18 ali CM19
- vijačna pritrnitev vodnikov 1.5-2.5 mm²
- ustreza IEC 60884-1, CEE7

SOCKETS SET 2x SCHUKO 2P+E 16A 250V~ 4M

- socket set 2x schuko VM10 2P+E 16A 250V~
- prewired with link wires CM16
- with mounting frame 4M without screws
- for mounting frame fixing use screws CM17, CM18 or CM19
- screw contacts 1.5-2.5 mm²
- in accordance with IEC-60884-1, CEE7

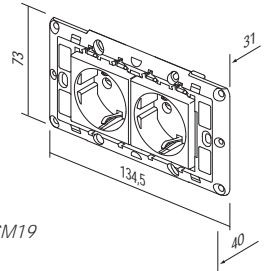

SET VTIČNIC 3x SCHUKO 2P+E 16A 250V~ 7M

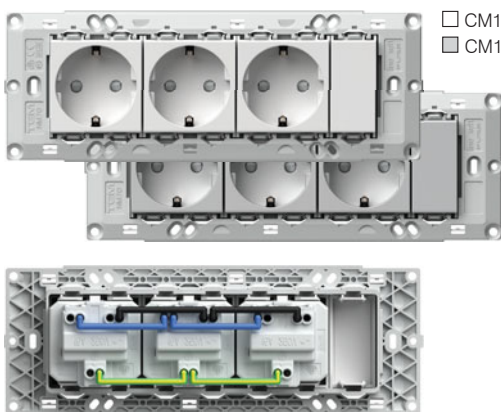

- CM11PW
- CM11ES

- set vtičnic 3x schuko VM10 2P+E 16A 250V~
- vtičnice povezane z vezniki CM16
- z nosilcem 7M brez vijakov
- za pritrnitev nosilcev uporabiti vijake CM17, CM18 ali CM19
- vijačna pritrnitev vodnikov 1.5-2.5 mm²
- ustreza IEC 60884-1, CEE7

SOCKETS SET 3x SCHUKO 2P+E 16A 250V~ 7M

- socket set 3x schuko VM10 2P+E 16A 250V~
- prewired with link wires CM16
- with mounting frame 7M without screws
- for mounting frame fixing use screws CM17, CM18 or CM19
- screw contacts 1.5-2.5 mm²
- in accordance with IEC-60884-1, CEE7

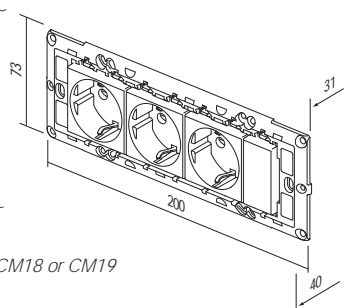

SET VEZNIKOV BARVNI 3x1.5mm² 1M

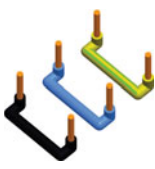

CM15

- set veznikov za povezavo dveh elementov velikosti 1M
- vsebuje 10 črnih, 10 modrih in 10 rumeno-zelenih veznikov

LINK WIRE SET 3x1.5mm² 1M

- link wire set to connect two elements size 1M
- includes 10 black, 10 blue and 10 yellow/green wires

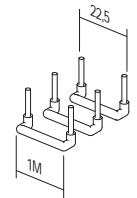

SET VEZNIKOV BARVNI 3x2.5mm² 2M

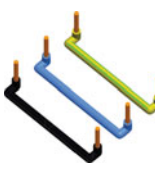

CM16

- set veznikov za povezavo dveh elementov velikosti 2M
- vsebuje 10 črnih, 10 modrih in 10 rumeno-zelenih veznikov

LINK WIRE SET 3x2.5mm² 2M

- link wire set to connect two elements size 2M
- includes 10 black, 10 blue and 10 yellow/green wires

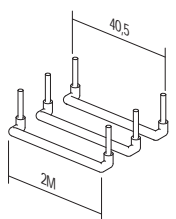

SET VIJAKOV 3,5



CM17
CM18
CM19

- set vijakov za pritrnitev nosilcev setov NM30, NM32, NM40, NM41, NM70
- CM17 - l=20mm, 100kos
- CM18 - l=35mm, 50kos
- CM19 - l=50mm, 50kos

SCREW SET 3,5

- screw set for fixing mounting frames NM30, NM32, NM40, NM41, NM70
- CM17 - l=20mm, 100pcs
- CM18 - l=35mm, 50pcs
- CM19 - l=50mm, 50pcs



SET ZA STIKALA IP44 2M



□ CM22PW

- za vgradnjo v vlažne prostore
- IP44 zaščito zagotavlja za vsa stikala Modul
- stikala in tipke niso sestavni del seta
- okvir SOFT 2M z napisno ploščico
- ustreza IEC 60669-1

SET SWITCHES IP44 2M

- for usage in humid areas
- IP44 protection provides for all Modul switches
- switches and buttons are not part of the set
- SOFT 2M cover plate with inscription plate
- in accordance with IEC 60669-1



SET ZA VTIČNICE IP44 2M



□ CM23PW

- za vgradnjo v vlažne prostore
- IP44 zaščito zagotavlja le v kombinaciji z vtičnico s pokrovom (VM11, VM41)
- vtičnice niso sestavni del seta
- okvir SOFT 2M z napisno ploščico
- ustreza IEC 60884-1

SET SOCKETS IP44 2M

- for usage in humid areas
- IP44 protection can be achieved only in combination with covered socket (VM11, VM41)
- sockets are not part of the set
- SOFT 2M cover plate with inscription plate
- in accordance with IEC 60884-1



KOPALNIŠKI SET 3x20AX 250V~ 4M



□ CM25PWOL
■ CM25IWOL
□ CM25PWOS
■ CM25IWOS

- set stikal 3xSM12 20AX 250V~ z nosilcem in okvirjem
- vijačna pritrnitev vodnikov 1.5-2.5mm²
- ustreza EN 60669-1
- možnost pritrditve na že vgrajene doze pritrditvenih mer od 108 do 135mm ali na doze velikosti 4M
- višina okvirja 90mm

SWITCH SET FOR BATHROOM 3x20AX 250V~ 4M

- switch set 3xSM12 20AX 250V~ with mounting frame and cover plate
- screw contacts 1.5-2.5mm²
- in accordance with EN 60669-1
- universal solution for renovation on boxes with fixing dimensions 108-135mm or boxes 4M size
- cover plate height 90mm



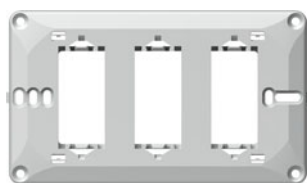

NM41

NOSILEC KOPALNIŠKI SET 4M

- nosilec kopalniški set univerzalni z vijaki
- možnost pritrditve na že vgrajene pravokotne doze pritrditvenih mer od 108 do 135mm ali na doze velikosti 4M
- ustreza EN 60669-1

MOUNTING FRAME BATHROOM SET 4M

- universal mounting frame for bathroom set with screws
- universal solution for mounting on rectangular boxes with fixing dimensions 108-135mm or boxes 4M size
- in accordance with EN 60669-1

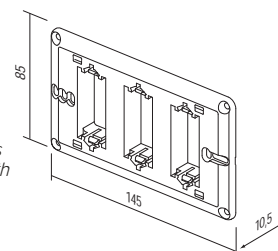

- OL41PW
- OL41NB
- OL41IW
- OL41ES
- OL41SG
- OL41IB
- OL41MG

OKVIR LINE KOPALNIŠKI SET

- dekorativni okvir kopalniški set LINE
- višina 90mm
- ustreza EN 60669-1

COVER PLATE LINE BATHROOM SET

- decorative cover plate bathroom set LINE
- height 90mm
- in accordance with EN 60669-1

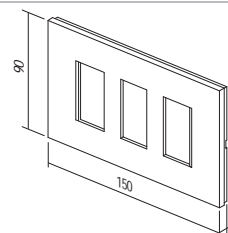

- OS41PW
- OS41NB
- OS41IW
- OS41ES
- OS41SG
- OS41SB
- OS41WE

OKVIR SOFT KOPALNIŠKI SET

- dekorativni okvir kopalniški set SOFT
- višina 90mm
- ustreza EN 60669-1

COVER PLATE SOFT BATHROOM SET

- decorative cover plate bathroom set SOFT
- height 90mm
- in accordance with EN 60669-1

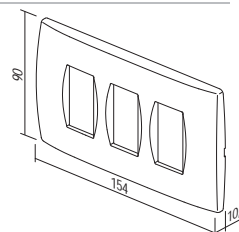



tip <i>type</i>	naziv <i>description</i>	velikost <i>size</i>	barva <i>colour</i>	opcijski opis 1 <i>optional data 1</i>
TM11	TIPKA <i>BUTTON</i>	1M	<input type="checkbox"/> AW antibakterijsko bela <i>antibacterial white</i>	 NT nevtral <i>neutral</i>
TM21	POLNILO <i>BLANK</i>	1M		 IN indikator <i>indicator</i>
VM10	VTIČNICA <i>SOCKET</i>	2M		
.	.	.		
.	.	.		
.	.	.		

ANTIBAKTERIJSKI PROGRAM MODUL

- stikala in vtičnice so vsakodnevno izpostavljene dotiku večjega števila ljudi, zato so to pogosta mesta za razvoj in širjenje bakterij
- zahvaljujoč svojim naravnim antibakterijskim lastnostim je srebro že 3 tisočletja v uporabi kot varno in učinkovito dezinfekcijsko sredstvo, saj je popolnoma naravno ter zdravju in okolju prijazno
- poseben antibakterijski dodatek srebrvih ionov zagotavlja dolgoročno, zanesljivo in učinkovito zaščito pred razvojem in širjenjem različnih bakterij, virusov, mikrobov in glivic
- antibakterijska zaščita pomeni večjo higieničnost, čistočo in zdravje ljudi
- antibakterijski program MODUL je primeren za uporabo povsod, kjer veljajo strogi higienski pogoji (bolnišnice, zdravstveni domovi, farmacevtski objekti, domovi za starejše, negovalni domovi, laboratoriji, restavracije, hoteli, letališča, avtobusne in železniške postaje, poslovni in trgovski prostori, javne institucije ...)
- laboratorijska testiranja so bila opravljena v neodvisni instituciji na podlagi najvišjih japonskih standardov JIS Z 2801
- nizki stroški za zagotavljanje zdravja ljudi
- oblika in funkcionalnost antibakterijskega programa MODUL omogočata enostavno čiščenje in vzdrževanje
- antibakterijski program MODUL kombiniramo z antibakterijskimi tipkami, okvirji in vtičnicami skupaj s klasičnimi nosilci in stikali
- vsak izdelek je zaradi lažje identifikacije na zadnji strani označen z AW (antibacterial white)

ANTIBACTERIAL PROGRAM MODUL

- switches and sockets are daily touched by many people, so this is a common place for development and spread of bacteria
- thanks to its natural antibacterial characteristics silver has been used for three millennia as a safe and effective disinfectant, since it is completely natural, healthy and environmentally friendly
- special antibacterial silver ions additive provides long-term, reliable and effective protection against the development and spread of bacteria, viruses, microbes and fungi
- antibacterial protection ensures hygiene, cleanliness and health for people
- perfectly suitable for use in environments with strict hygiene conditions (hospitals, health centers, pharmaceutical facilities, homes for elderly, nursing homes, laboratories, restaurants, hotels, airports, bus and railway stations, business and shopping areas, public institutions ...)
- independent laboratory testings have been carried out in accordance with highest Japanese standards JIS Z 2801
- low cost for providing human health
- design and functionality of antibacterial program MODUL allow easy cleaning and maintenance
- antibacterial buttons, cover plates and sockets are combined with classic mounting frames and switches
- products are labelled on the back with AW (antibacterial white)

A N T I B A C T E R I A L P R O G R A M M O D U L

TIPKA 1M



□ TM11AW

- zamenljiva tipka velikosti 1M
- ustreza EN 60669-1
- antibakterijska zaščita skladna z JIS Z 2801

BUTTON 1M

- replaceable button 1M
- in accordance with EN 60669-1
- antibacterial protection in accordance with JIS Z 2801



TIPKA 1M INDIKATOR



□ TM11AWIN

- zamenljiva tipka velikosti 1M
- ustreza EN 60669-1
- antibakterijska zaščita skladna z JIS Z 2801

BUTTON 1M INDICATOR

- replaceable button 1M
- in accordance with EN 60669-1
- antibacterial protection in accordance with JIS Z 2801



TIPKA 2M



□ TM12AW

- zamenljiva tipka velikost 2M z nosilcem tipke
- uporablja se pri nadgradnji stikala ali tipkala velikosti 1M v velikost 2M
- ustreza EN 60669-1
- antibakterijska zaščita skladna z JIS Z 2801

BUTTON 2M

- replaceable button 2M with button carrier
- to upgrade switch or push button from size 1M to size 2M
- in accordance with EN 60669-1
- antibacterial protection in accordance with JIS Z 2801



TIPKA 2M INDIKATOR



□ TM12AWIN

- zamenljiva tipka velikost 2M z nosilcem tipke
- uporablja se pri nadgradnji stikala ali tipkala velikosti 1M v velikost 2M
- ustreza EN 60669-1
- antibakterijska zaščita skladna z JIS Z 2801

BUTTON 2M INDICATOR

- replaceable button 2M with button carrier
- to upgrade switch or push button from size 1M to size 2M
- in accordance with EN 60669-1
- antibacterial protection in accordance with JIS Z 2801



POLNILO 1M



□ TM21AW

- za zapolnjevanje praznih mest
- ustreza EN 60669-1
- antibakterijska zaščita skladna z JIS Z 2801

BLANK 1M

- blank modul to fill up empty spaces
- in accordance with EN 60669-1
- antibacterial protection in accordance with JIS Z 2801



POLNILO 2M



□ TM22AW

- za zapolnjevanje praznih mest
- ustreza EN 60669-1
- antibakterijska zaščita skladna z JIS Z 2801

BLANK 2M

- blank modul to fill up empty spaces
- in accordance with EN 60669-1
- antibacterial protection in accordance with JIS Z 2801





□ VM10AW

VTIČNICA SCHUKO+KS 2P+E 16A 250V~ 2M

- 2P+E schuko
- 16A 250V~, tip VM10
- ustreza IEC 60884-1, CEE7
- vijačna pritrditev vodnikov 1.5-2.5 mm²
- KS vgrajena otroška zaščita pred dotikom kontaktov
- antibakterijska zaščita skladna z JIS Z 2801

SOCKET SCHUKO+KS 2P+E 16A 250V~ 2M

- 2P+E schuko
- 16A 250V~, type VM10
- in accordance with IEC 60884-1, CEE7
- screw contacts 1.5-2.5 mm²
- KS build-in child protection - shuttered live contacts
- antibacterial protection in accordance with JIS Z 2801



□ VM11AW

VTIČNICA SCHUKO+KS+POKROV 2P+E 16A 250V~ 2M

- 2P+E schuko+pokrov
- 16A 250V~, tip VM11
- ustreza IEC 60884-1, CEE7
- vijačna pritrditev vodnikov 1.5-2.5 mm²
- KS vgrajena otroška zaščita pred dotikom kontaktov
- antibakterijska zaščita skladna z JIS Z 2801

SOCKET SCHUKO+KS+COVER

- 2P+E 16A 250V~ 2M
- 2P+E schuko+cover
- 16A 250V~, type VM11
- in accordance with IEC 60884-1, CEE7
- screw contacts 1.5-2.5 mm²
- KS build-in child protection - shuttered live contacts
- antibacterial protection in accordance with JIS Z 2801



□ VM20AW

VTIČNICA EURO+KS 2P 10A 250V~ 1M

- 2P euro
- 10A 250V~, tip VM20
- ustreza IEC 60884-1, CEE7
- vijačna pritrditev vodnikov 1.5-2.5 mm²
- KS vgrajena otroška zaščita pred dotikom kontaktov
- antibakterijska zaščita skladna z JIS Z 2801

SOCKET EURO+KS 2P 10A 250V~ 1M

- 2P Euro
- 10A 250V~, type VM20
- in accordance with IEC 60884-1, CEE7
- screw contacts 1.5-2.5 mm²
- KS build-in child protection - shuttered live contacts
- antibacterial protection in accordance with JIS Z 2801



□ KM11AW

VTIČNICA TV KONČNA 1dB 1M

- TV končna
- frekvenčni pas 5÷2400 MHz
- dušenje < 1 dB
- ustreza EN 50083-1
- vijačna priključitev
- antibakterijska zaščita skladna z JIS Z 2801

SOCKET TV END-LINE 1dB 1M

- TV end-line
- frequency range 5÷2400 MHz
- reduction < 1 dB
- in accordance with EN 50083-1
- screw contacts
- antibacterial protection in accordance with JIS Z 2801

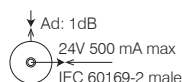

□ KM35AW

ADAPTER KS 1M

- KS keystone pritrditveni standard
- AMP, Avaya, Brandrex, FMT, Mfico, Tyco, ...
- komunikacijski modul ni vgrajen
- antibakterijska zaščita skladna z JIS Z 2801

ADAPTER KS 1M

- KS keystone fixing standard
- AMP, Avaya, Brandrex, FMT, Mfico, Tyco, ...
- communication module not included
- antibacterial protection in accordance with JIS Z 2801



A N T I B A C T E R I A L P R O G R A M M O D U L



OS20AW

OKVIR SOFT 2M

- dekorativni okvir SOFT 2M
- ustreza EN 60669-1
- antibakterijska zaščita skladna z JIS Z 2801

COVER PLATE SOFT 2M

- decorative cover plate SOFT 2M
- in accordance with EN 60669-1
- antibacterial protection in accordance with JIS Z 2801



OS24AW

OKVIR SOFT 2x2M

- dekorativni okvir SOFT 2x2M
- horizontalna ali vertikalna vgradnja
- ustreza EN 60669-1
- antibakterijska zaščita skladna z JIS Z 2801

COVER PLATE SOFT 2x2M

- decorative cover plate SOFT 2x2M
- horizontal or vertical mounting
- in accordance with EN 60669-1
- antibacterial protection in accordance with JIS Z 2801



OS26AW

OKVIR SOFT 3x2M

- dekorativni okvir SOFT 3x2M
- horizontalna ali vertikalna vgradnja
- ustreza EN 60669-1
- antibakterijska zaščita skladna z JIS Z 2801

COVER PLATE SOFT 3x2M

- decorative cover plate SOFT 3x2M
- horizontal or vertical mounting
- in accordance with EN 60669-1
- antibacterial protection in accordance with JIS Z 2801



OS30AW

OKVIR SOFT 3M

- dekorativni okvir SOFT 3M
- ustreza EN 60669-1
- antibakterijska zaščita skladna z JIS Z 2801

COVER PLATE SOFT 3M

- decorative cover plate SOFT 3M
- antibacterial protection in accordance with JIS Z 2801
- in accordance with EN 60669-1



OS40AW

OKVIR SOFT 4M

- dekorativni okvir SOFT 4M
- ustreza EN 60669-1
- antibakterijska zaščita skladna z JIS Z 2801

COVER PLATE SOFT 4M

- decorative cover plate SOFT 4M
- in accordance with EN 60669-1
- antibacterial protection in accordance with JIS Z 2801

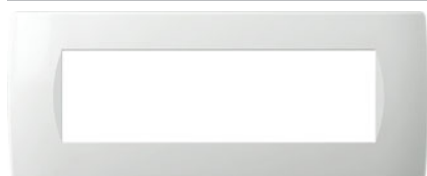

OS70AW

OKVIR SOFT 7M

- dekorativni okvir SOFT 7M
- ustreza EN 60669-1
- antibakterijska zaščita skladna z JIS Z 2801

COVER PLATE SOFT 7M

- decorative cover plate SOFT 7M
- in accordance with EN 60669-1
- antibacterial protection in accordance with JIS Z 2801

kovina
metal

MH kovano jeklo
hammered steel



ME zarjavelo železo
etched iron

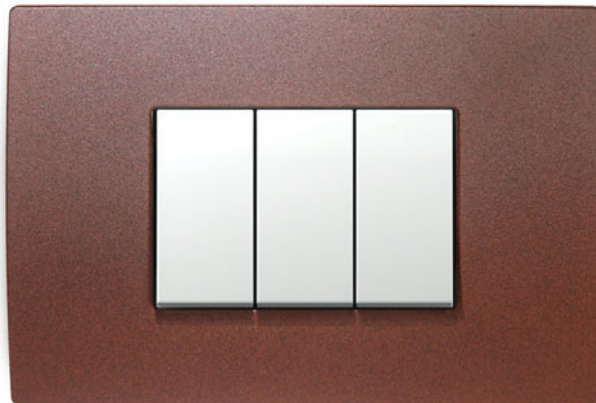

MS satinirano srebro
satín silver

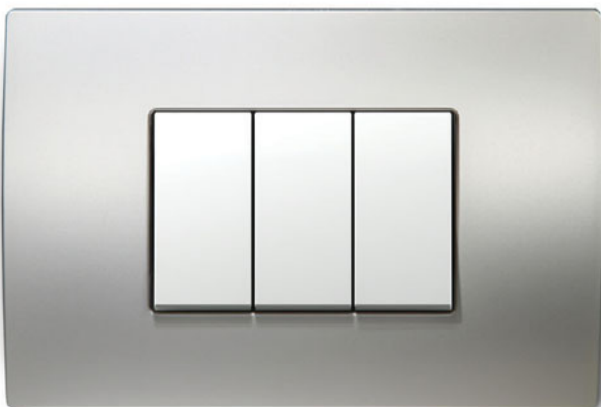

MN satiniran nikelj
satín nickel



COVER PLATES PURE OP

les
wood

WB bambus
bamboo



WW oreh
walnut

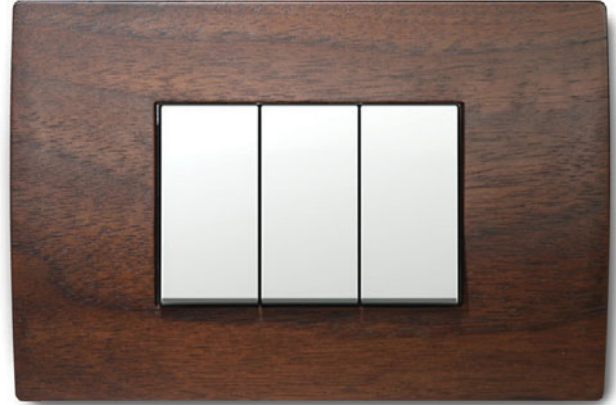

WM javor
maple

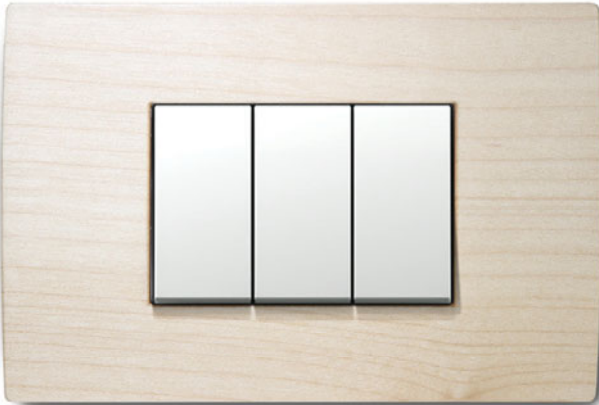

WE wenge
wenge

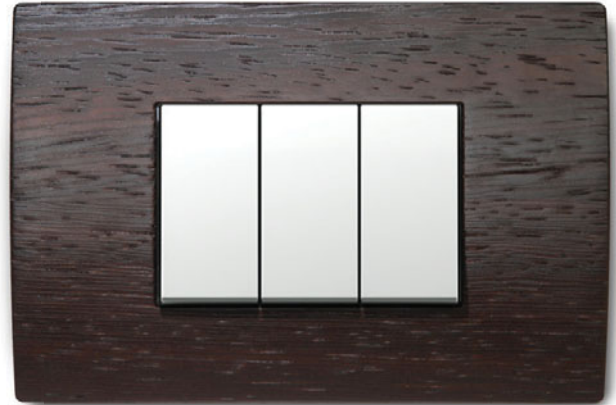

steklo
glass

GW ledeno bela
ice white

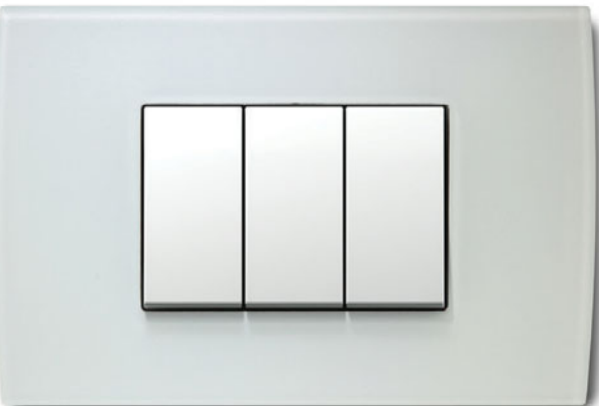

GG ledeno zelena
ice green

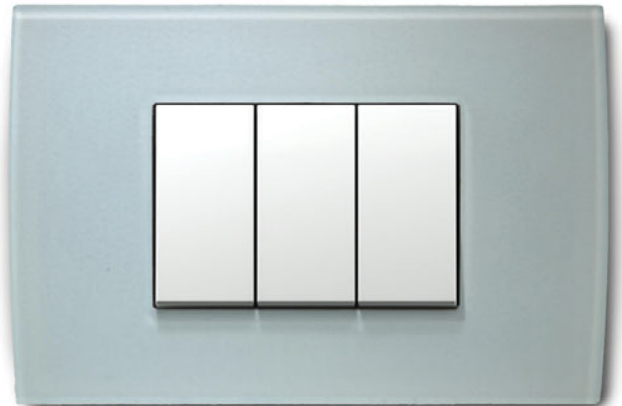

GY ledeno sive
ice grey



GB ledeno modra
ice blue

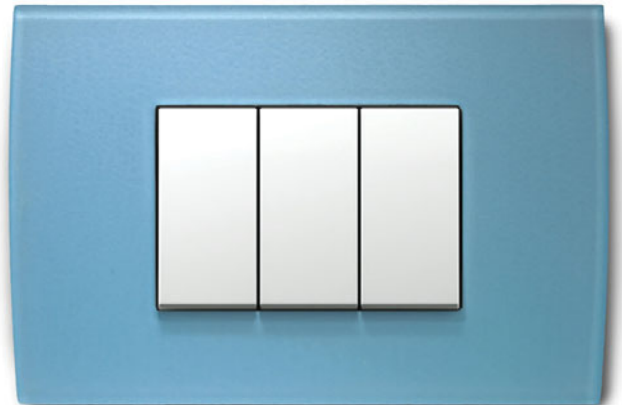



OP30

WB

tip type	naziv description	velikost size	barva colour	
OP13	OKVIR PURE COVER PLATE PURE	1/3M	MH kovano jeklo <i>hammered steel</i>	WB bambus <i>bamboo</i>
OP20	OKVIR PURE COVER PLATE PURE	2M	ME zarjavelo železo <i>etched iron</i>	WW oreh <i>walnut</i>
OP23	OKVIR PURE COVER PLATE PURE	2/3M	MS satinirano srebro <i>satın silver</i>	WM javor <i>maple</i>
·	·	·	MN satiniran nikelj <i>satın nickel</i>	WE wenge <i>wenge</i>
·	·	·		GW ledeno bela <i>ice white</i>
·	·	·		GG ledeno zelena <i>ice green</i>
·	·	·		GY ledeno siva <i>ice grey</i>
·	·	·		GB ledeno modra <i>ice blue</i>



OP20MH	OP20WB
OP20ME	OP20WW
OP20MS	OP20WM
OP20MN	OP20WE
	OP20GW
	OP20GG
	OP20GY
	OP20GB

OKVIR PURE 2M

- dekorativni okvir PURE 2M
- ustreza EN 60669-1
- samo v kombinaciji z nosilcem NM24 ali NM25

COVER PLATE PURE 2M
- decorative cover plate PURE 2M
- in accordance with EN 60669-1
- only in combination with mounting frame NM24 or NM25

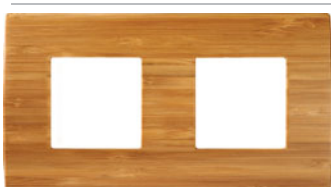

OP24MH	OP24WB
OP24ME	OP24WW
OP24MS	OP24WM
OP24MN	OP24WE
	OP24GW
	OP24GG
	OP24GY
	OP24GB

OKVIR PURE 2x2M

- dekorativni okvir PURE 2x2M
- horizontalna ali vertikalna vgradnja
- ustreza EN 60669-1
- samo v kombinaciji z nosilcema NM24 ali NM25

COVER PLATE PURE 2x2M
- decorative cover plate PURE 2x2M
- horizontal or vertical mounting
- in accordance with EN 60669-1
- only in combination with mounting frames NM24 or NM25



OP26MH	OP26WB
OP26ME	OP26WW
OP26MS	OP26WM
OP26MN	OP26WE
	OP26GW
	OP26GG
	OP26GY
	OP26GB

OKVIR PURE 3x2M

- dekorativni okvir PURE 3x2M
- horizontalna ali vertikalna vgradnja
- ustreza EN 60669-1
- samo v kombinaciji z nosilci NM24 ali NM25

COVER PLATE PURE 3x2M
- decorative cover plate PURE 3x2M
- horizontal or vertical mounting
- in accordance with EN 60669-1
- only in combination with mounting frames NM24 or NM25

COVER PLATES PURE OP



OP30MH
OP30ME
OP30MS
OP30MN

OP30WB
OP30WW
OP30WM
OP30WE
OP30GW
OP30GG
OP30GY
OP30GB

OKVIR PURE 3M

- dekorativni okvir PURE 3M
- ustreza EN 60669-1

COVER PLATE PURE 3M

- decorative cover plate PURE 3M
- in accordance with EN 60669-1



OP40MH
OP40ME
OP40MS
OP40MN

OP40WB
OP40WW
OP40WM
OP40WE
OP40GW
OP40GG
OP40GY
OP40GB

OKVIR PURE 4M

- dekorativni okvir PURE 4M
- ustreza EN 60669-1

COVER PLATE PURE 4M

- decorative cover plate PURE 4M
- in accordance with EN 60669-1



OP70MH
OP70ME
OP70MS
OP70MN

OP70WB
OP70WW
OP70WM
OP70WE
OP70GW
OP70GG
OP70GY
OP70GB

OKVIR PURE 7M

- dekorativni okvir PURE 7M
- ustreza EN 60669-1

COVER PLATE PURE 7M

- decorative cover plate PURE 7M
- in accordance with EN 60669-1

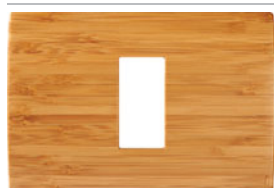

OP13MH
OP13ME
OP13MS
OP13MN

OP13WB
OP13WW
OP13WM
OP13WE
OP13GW
OP13GG
OP13GY
OP13GB

OKVIR PURE 1/3M

- dekorativni okvir PURE 1/3M
- ustreza EN 60669-1

COVER PLATE PURE 1/3M

- decorative cover plate PURE 1/3M
- in accordance with EN 60669-1

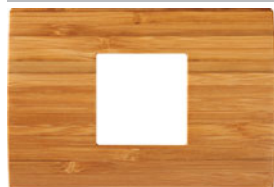

OP23MH
OP23ME
OP23MS
OP23MN

OP23WB
OP23WW
OP23WM
OP23WE
OP23GW
OP23GG
OP23GY
OP23GB

OKVIR PURE 2/3M

- dekorativni okvir PURE 2/3M
- ustreza EN 60669-1

COVER PLATE PURE 2/3M

- decorative cover plate PURE 2/3M
- in accordance with EN 60669-1

basic
basic

PW bela-sijaj
polar white



IW bež-sijaj
ivory white

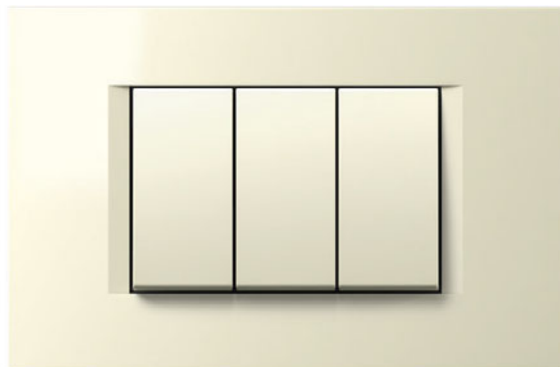

ES srebrna-mat
elox silver



SB črna-mat
soft touch black

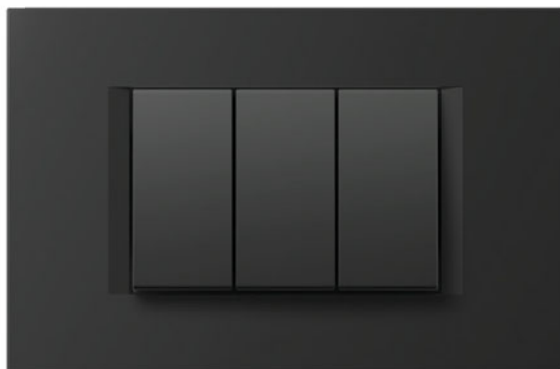

COVER PLATES LINE OL

dekor
decor

SG zlata-mat
sand gold

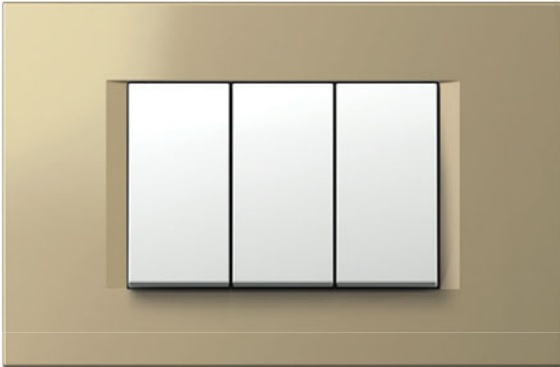

NB črna-sijaj
night black

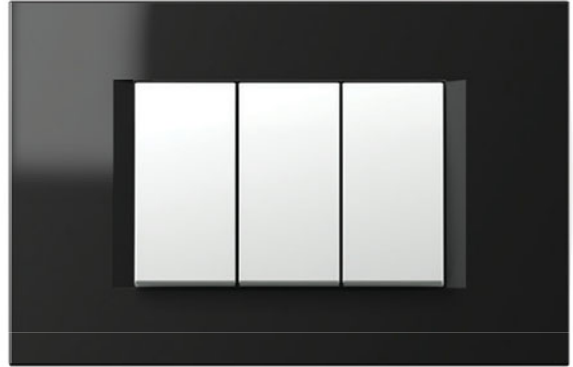

IB modra-mat
impulse blue

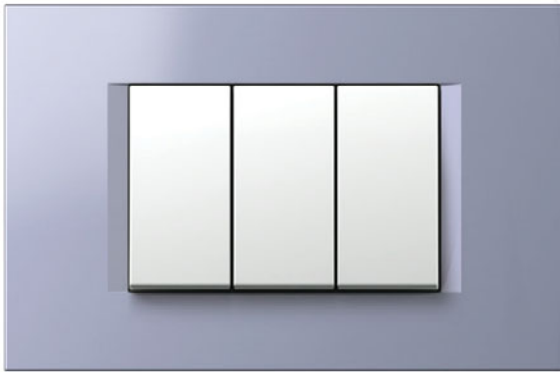

MG zelena-mat
mint green

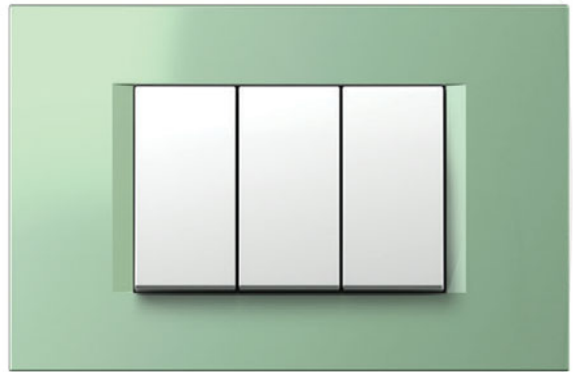

SE kamen emerald
stone emerald



SW kamen beli
stone white





OL30

PW

tip type	naziv description	velikost size	barva colour																								
OL10	OKVIR LINE COVER PLATE LINE	1/2M	<table border="0"> <tr> <td></td> <td>PW bela-sijaj polar white</td> <td></td> <td>SG zlata-mat sand gold</td> <td></td> <td>SE kamen emerald stone emerald</td> </tr> <tr> <td></td> <td>IW bež-sijaj ivory white</td> <td></td> <td>NB črna-sijaj night black</td> <td></td> <td>SW kamen beli stone white</td> </tr> <tr> <td></td> <td>ES srebrna-mat elox silver</td> <td></td> <td>IB modra-mat impulse blue</td> <td></td> <td></td> </tr> <tr> <td></td> <td>SB črna-mat soft touch black</td> <td></td> <td>MG zelena-mat mint green</td> <td></td> <td></td> </tr> </table>		PW bela-sijaj polar white		SG zlata-mat sand gold		SE kamen emerald stone emerald		IW bež-sijaj ivory white		NB črna-sijaj night black		SW kamen beli stone white		ES srebrna-mat elox silver		IB modra-mat impulse blue				SB črna-mat soft touch black		MG zelena-mat mint green		
	PW bela-sijaj polar white		SG zlata-mat sand gold		SE kamen emerald stone emerald																						
	IW bež-sijaj ivory white		NB črna-sijaj night black		SW kamen beli stone white																						
	ES srebrna-mat elox silver		IB modra-mat impulse blue																								
	SB črna-mat soft touch black		MG zelena-mat mint green																								
OL13	OKVIR LINE COVER PLATE LINE	1/3M																									
OL20	OKVIR LINE COVER PLATE LINE	2M																									
.	.	.	.																								
.	.	.	.																								



	OL20PW		OL20SG
	OL20IW		OL20NB
	OL20ES		OL20IB
	OL20SB		OL20MG
			OL20SE
			OL20SW

OKVIR LINE 2M

- dekorativni okvir LINE 2M
- ustreza EN 60669-1

COVER PLATE LINE 2M

- decorative cover plate LINE 2M
- in accordance with EN 60669-1



	OL24PW		OL24SG
	OL24IW		OL24NB
	OL24ES		OL24IB
	OL24SB		OL24MG
			OL24SE
			OL24SW

OKVIR LINE 2x2M

- dekorativni okvir LINE 2x2M
- horizontalna ali vertikalna vgradnja
- ustreza EN 60669-1

COVER PLATE LINE 2x2M

- decorative cover plate LINE 2x2M
- horizontal or vertical mounting
- in accordance with EN 60669-1

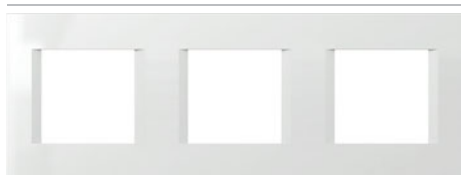

	OL26PW		OL26SG
	OL26IW		OL26NB
	OL26ES		OL26IB
	OL26SB		OL26MG
			OL26SE
			OL26SW

OKVIR LINE 3x2M

- dekorativni okvir LINE 3x2M
- horizontalna ali vertikalna vgradnja
- ustreza EN 60669-1

COVER PLATE LINE 3x2M

- decorative cover plate LINE 3x2M
- horizontal or vertical mounting
- in accordance with EN 60669-1



	OL28PW		OL28SG
	OL28IW		OL28NB
	OL28ES		OL28IB
	OL28SB		OL28MG
			OL28SE
			OL28SW

OKVIR LINE 4x2M

- dekorativni okvir LINE 4x2M
- horizontalna ali vertikalna vgradnja
- ustreza EN 60669-1

COVER PLATE LINE 4x2M

- decorative cover plate LINE 4x2M
- horizontal or vertical mounting
- in accordance with EN 60669-1

COVER PLATES LINE OL



	OL30PW		OL30SG
	OL30IW		OL30NB
	OL30ES		OL30IB
	OL30SB		OL30MG
			OL30SE
			OL30SW

OKVIR LINE 3M

- dekorativni okvir LINE 3M
- ustreza EN 60669-1

COVER PLATE LINE 3M

- decorative cover plate LINE 3M
- in accordance with EN 60669-1



	OL40PW		OL40SG
	OL40IW		OL40NB
	OL40ES		OL40IB
	OL40SB		OL40MG
			OL40SE
			OL40SW

OKVIR LINE 4M

- dekorativni okvir LINE 4M
- ustreza EN 60669-1

COVER PLATE LINE 4M

- decorative cover plate LINE 4M
- in accordance with EN 60669-1

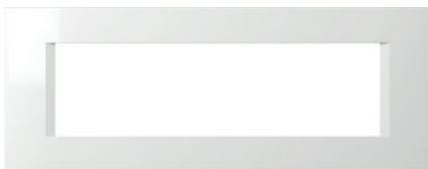

	OL70PW		OL70SG
	OL70IW		OL70NB
	OL70ES		OL70IB
	OL70SB		OL70MG
			OL70SE
			OL70SW

OKVIR LINE 7M

- dekorativni okvir LINE 7M
- ustreza EN 60669-1

COVER PLATE LINE 7M

- decorative cover plate LINE 7M
- in accordance with EN 60669-1



	OL10PW		OL10SG
	OL10IW		OL10NB
	OL10ES		OL10IB
	OL10SB		OL10MG
			OL10SE
			OL10SW

OKVIR LINE 1/2M

- dekorativni okvir LINE 1/2M
- ustreza EN 60669-1

COVER PLATE LINE 1/2M

- decorative cover plate LINE 1/2M
- in accordance with EN 60669-1



	OL13PW		OL13SG
	OL13IW		OL13NB
	OL13ES		OL13IB
	OL13SB		OL13MG
			OL13SE
			OL13SW

OKVIR LINE 1/3M

- dekorativni okvir LINE 1/3M
- ustreza EN 60669-1

COVER PLATE LINE 1/3M

- decorative cover plate LINE 1/3M
- in accordance with EN 60669-1



	OL23PW		OL23SG
	OL23IW		OL23NB
	OL23ES		OL23IB
	OL23SB		OL23MG
			OL23SE
			OL23SW

OKVIR LINE 2/3M

- dekorativni okvir LINE 2/3M
- ustreza EN 60669-1

COVER PLATE LINE 2/3M

- decorative cover plate LINE 2/3M
- in accordance with EN 60669-1

basic
basic

PW bela-sijaj
polar white

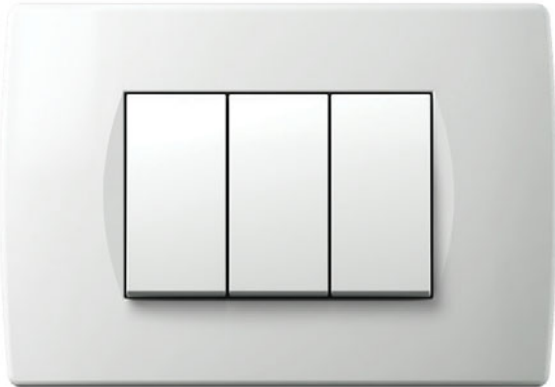

IW bež-sijaj
ivory white

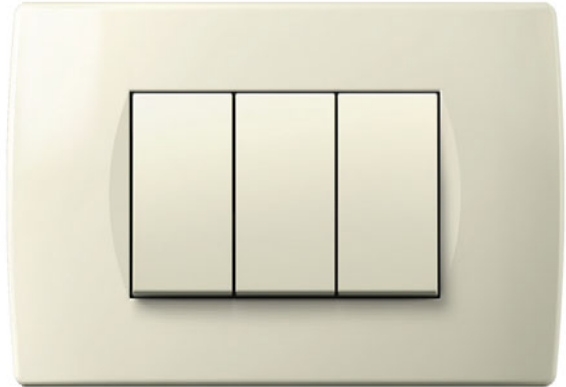

ES srebrna-mat
elox silver

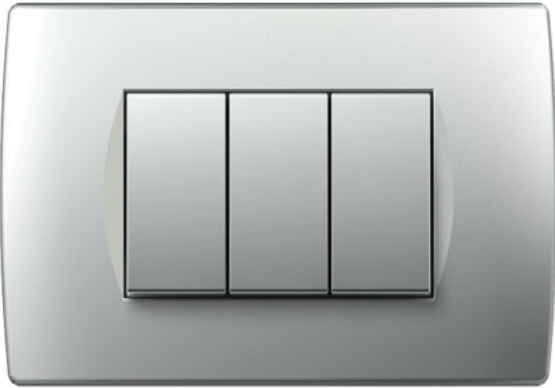

SB črna-mat
soft touch black

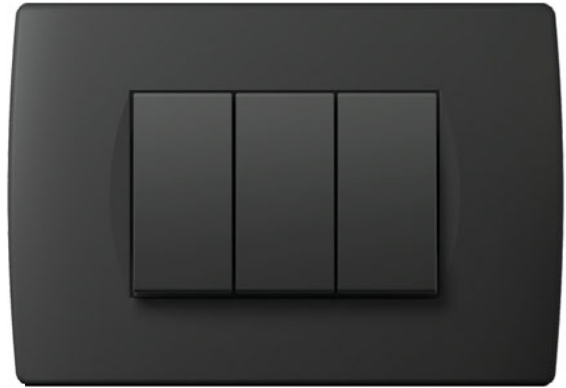

C O V E R P L A T E S S O F T O S

dekor
decor

SG zlata-mat
sand gola

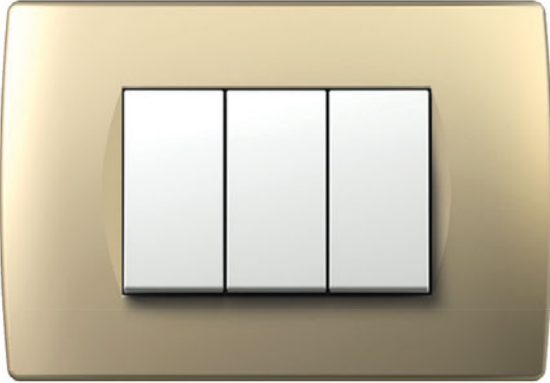

NB črna-sijaj
night black

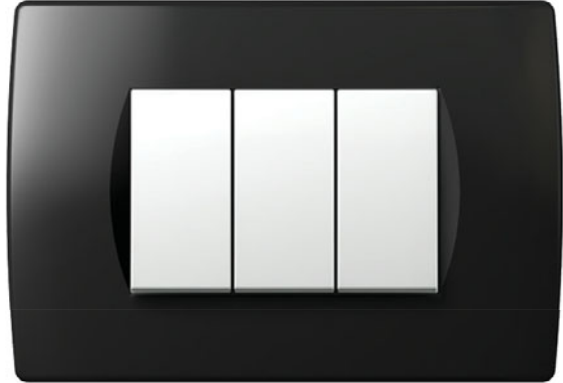

WP smreka
spruce



WW oreh
walnut



WE wenge
wenge





OS30

PW

tip type	naziv description	velikost size	barva colour								
OS10	OKVIR SOFT COVER PLATE SOFT	1/2M	<table border="0"> <tr> <td></td> <td>PW bela-sijaj polar white</td> <td></td> <td>SG zlata-mat sand gold</td> <td></td> <td>WP smreka spruce</td> </tr> </table>		PW bela-sijaj polar white		SG zlata-mat sand gold		WP smreka spruce		
	PW bela-sijaj polar white		SG zlata-mat sand gold		WP smreka spruce						
OS13	OKVIR SOFT COVER PLATE SOFT	1/3M	<table border="0"> <tr> <td></td> <td>IW bež-sijaj ivory white</td> <td></td> <td>NB črna-sijaj night black</td> <td></td> <td>WW oreh walnut</td> </tr> </table>		IW bež-sijaj ivory white		NB črna-sijaj night black		WW oreh walnut		
	IW bež-sijaj ivory white		NB črna-sijaj night black		WW oreh walnut						
OS20	OKVIR SOFT COVER PLATE SOFT	2M	<table border="0"> <tr> <td></td> <td>ES srebrna-mat elox silver</td> <td></td> <td>WE wenge wenge</td> </tr> <tr> <td></td> <td>SB črna-mat soft touch black</td> <td></td> <td></td> </tr> </table>		ES srebrna-mat elox silver		WE wenge wenge		SB črna-mat soft touch black		
	ES srebrna-mat elox silver		WE wenge wenge								
	SB črna-mat soft touch black										



	OS20PW		OS20SG
	OS20IW		OS20NB
	OS20ES		OS20WP
	OS20SB		OS20WW
			OS20WE

OKVIR SOFT 2M

- dekorativni okvir SOFT 2M
- ustreza EN 60669-1

COVER PLATE SOFT 2M

- decorative cover plate SOFT 2M
- in accordance with EN 60669-1



	OS24PW		OS24SG
	OS24IW		OS24NB
	OS24ES		OS24WP
	OS24SB		OS24WW
			OS24WE

OKVIR SOFT 2x2M

- dekorativni okvir SOFT 2x2M
- horizontalna ali vertikalna vgradnja
- ustreza EN 60669-1

COVER PLATE SOFT 2x2M

- decorative cover plate SOFT 2x2M
- horizontal or vertical mounting
- in accordance with EN 60669-1



	OS26PW		OS26SG
	OS26IW		OS26NB
	OS26ES		OS26WP
	OS26SB		OS26WW
			OS26WE

OKVIR SOFT 3x2M

- dekorativni okvir SOFT 3x2M
- horizontalna ali vertikalna vgradnja
- ustreza EN 60669-1

COVER PLATE SOFT 3x2M

- decorative cover plate SOFT 3x2M
- horizontal or vertical mounting
- in accordance with EN 60669-1



	OS28PW		OS28SG
	OS28IW		OS28NB
	OS28ES		OS28WP
	OS28SB		OS28WW
			OS28WE

OKVIR SOFT 4x2M

- dekorativni okvir SOFT 4x2M
- horizontalna ali vertikalna vgradnja
- ustreza EN 60669-1

COVER PLATE SOFT 4x2M

- decorative cover plate SOFT 4x2M
- horizontal or vertical mounting
- in accordance with EN 60669-1

COVER PLATES SOFT OS



 OS30PW	 OS30SG
 OS30IW	 OS30NB
 OS30ES	 OS30WP
 OS30SB	 OS30WW
	 OS30WE

OKVIR SOFT 3M

- dekorativni okvir SOFT 3M
- ustreza EN 60669-1

COVER PLATE SOFT 3M

- decorative cover plate SOFT 3M
- in accordance with EN 60669-1



 OS40PW	 OS40SG
 OS40IW	 OS40NB
 OS40ES	 OS40WP
 OS40SB	 OS40WW
	 OS40WE

OKVIR SOFT 4M

- dekorativni okvir SOFT 4M
- ustreza EN 60669-1

COVER PLATE SOFT 4M

- decorative cover plate SOFT 4M
- in accordance with EN 60669-1

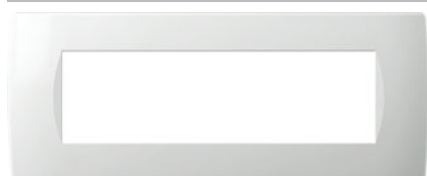

 OS70PW	 OS70SG
 OS70IW	 OS70NB
 OS70ES	 OS70WP
 OS70SB	 OS70WW
	 OS70WE





OKVIR SOFT 7M

- dekorativni okvir SOFT 7M
- ustreza EN 60669-1

COVER PLATE SOFT 7M

- decorative cover plate SOFT 7M
- in accordance with EN 60669-1



 OS72PW	 OS72IW
 OS72ES	 OS72SB

OKVIR SOFT 2x7M

- dekorativni okvir SOFT 2x7M z
napisno ploščico
- ustreza EN 60669-1

COVER PLATE SOFT 2x7M

- decorative cover plate SOFT 2x7M with
inscription plate
- in accordance with EN 60669-1



 OS10PW	 OS10SG
 OS10IW	 OS10NB
 OS10ES	 OS10WP
 OS10SB	 OS10WW
	 OS10WE

OKVIR SOFT 1/2M

- dekorativni okvir SOFT 1/2M
- ustreza EN 60669-1

COVER PLATE SOFT 1/2M

- decorative cover plate SOFT 1/2M
- in accordance with EN 60669-1



 OS13PW	 OS13SG
 OS13IW	 OS13NB
 OS13ES	 OS13WP
 OS13SB	 OS13WW
	 OS13WE

OKVIR SOFT 1/3M

- dekorativni okvir SOFT 1/3M
- ustreza EN 60669-1

COVER PLATE SOFT 1/3M

- decorative cover plate SOFT 1/3M
- in accordance with EN 60669-1



 OS23PW	 OS23SG
 OS23IW	 OS23NB
 OS23ES	 OS23WP
 OS23SB	 OS23WW
	 OS23WE

OKVIR SOFT 2/3M

- dekorativni okvir SOFT 2/3M
- ustreza EN 60669-1

COVER PLATE SOFT 2/3M

- decorative cover plate SOFT 2/3M
- in accordance with EN 60669-1

LASERSKI TISK NA OKVIRJE



- laserski tisk poljubne grafike
- izdelava po naročilu
- primerno za okvirje OL, OS

LASER PRINT ON COVER PLATES

- laser print of any graphics
- made on request
- suitable for cover plates OL, OS

DEKORACIJE OKVIRJEV









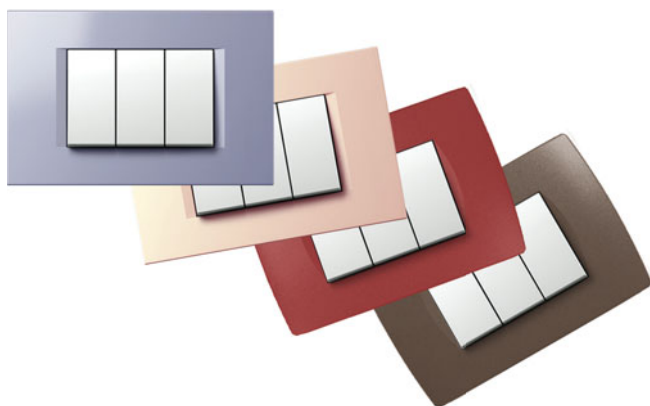

- vzorci in barve po izbiri
- izdelava po naročilu
- primerno za okvirje OL, OS

COVER PLATES DECORATIONS

- customised textures and colours
- made on request
- suitable for cover plates OL, OS

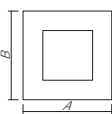
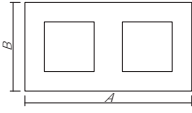
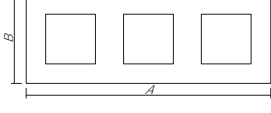
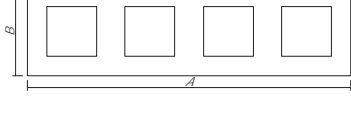

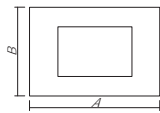
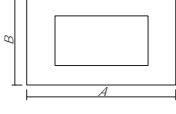
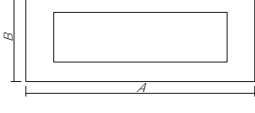
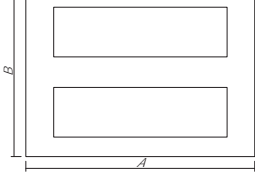
O K V I R J I

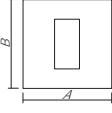
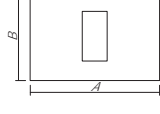
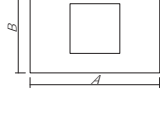
		 line A x B	 soft A x B	 PURE A x B
				
2M		80 x 80 mm	84 x 84 mm	93 x 90 mm
2x2M		151 x 80 mm	155 x 84 mm	164 x 90 mm
3x2M		222 x 80 mm	226 x 84 mm	235 x 90 mm
4x2M		293 x 80 mm	297 x 84 mm	
				
3M		122 x 80 mm	122 x 84 mm	134 x 90 mm
4M		149 x 80 mm	144 x 84 mm	157 x 90 mm
7M		207 x 80 mm	212 x 84 mm	224 x 90 mm
2x7M			212 x 158 mm	
				
1/2M		80 x 80 mm	84 x 84 mm	
1/3M		122 x 80 mm	122 x 84 mm	134 x 90 mm
2/3M		122 x 80 mm	122 x 84 mm	134 x 90 mm

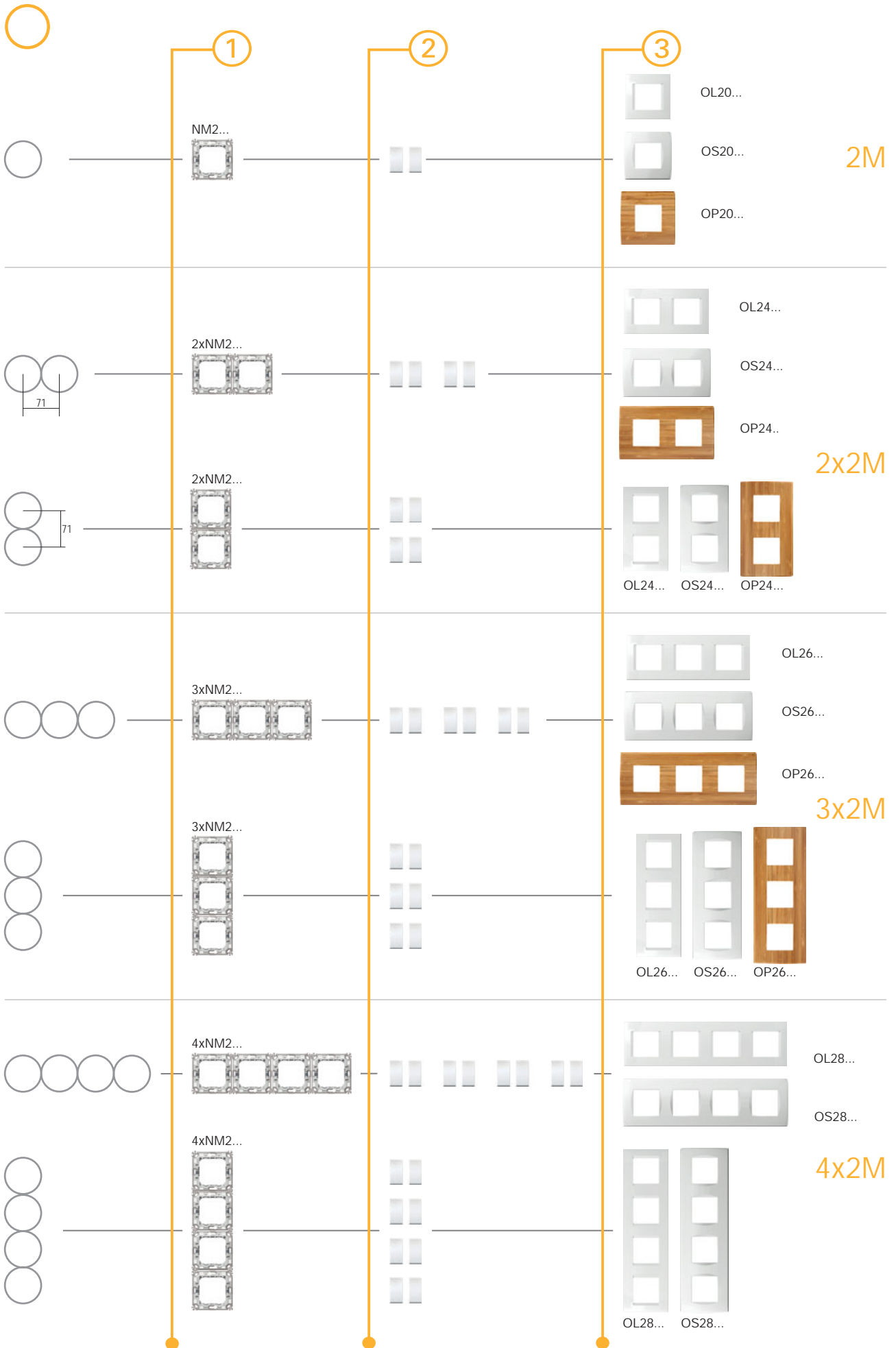

C O M B I N A T I O N S

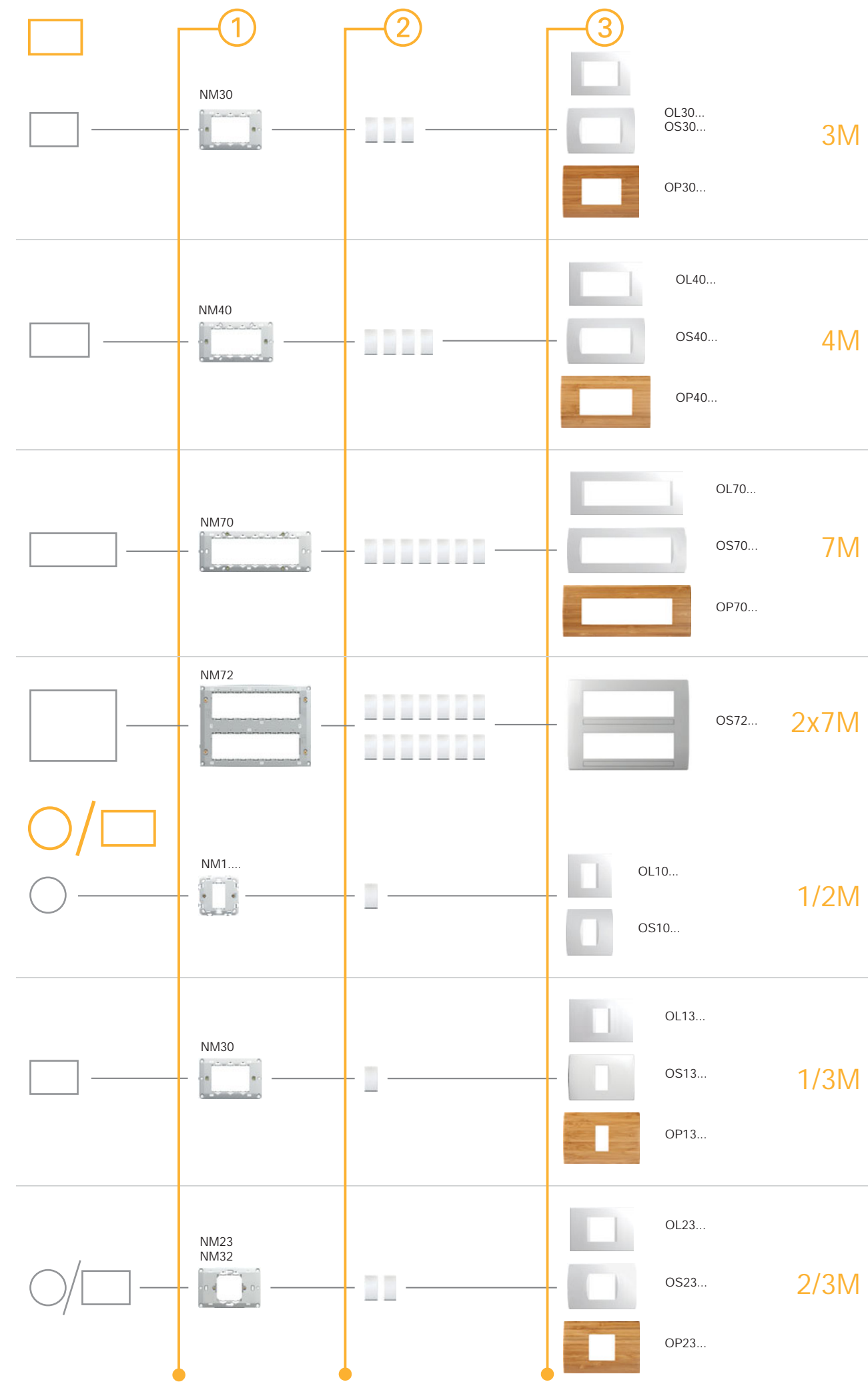



NM30

tip type	naziv description	velikost size
NM10	NOSILEC S KREPELJCI MOUNTING FRAME WITH CLAWS	1/2M
NM11	NOSILEC BREZ VIJAKOV MOUNTING FRAME WITHOUT SCREWS	1/2M
NM20	NOSILEC S KREPELJCI MOUNTING FRAME WITH CLAWS	2M
.	.	.
.	.	.



NOSILEC S KREPELJCI 2M



NM20

- nosilec 2M s krepeljci
- montaža v doze Ø60 (DE..) s krepeljci
- možno horizontalno ali vertikalno nizanje 2x2M, 3x2M in 4x2M
- primeren za sestavo z okvirji LINE in SOFT
- ustreza EN 60669-1

MOUNTING FRAME WITH CLAWS 2M

- mounting frame 2M with claws
- for mounting on boxes Ø60 (DE..) with claws
- possible horizontal or vertical combinations 2x2M, 3x2M and 4x2M
- suitable for assembling with cover plates LINE and SOFT
- in accordance with EN 60669-1

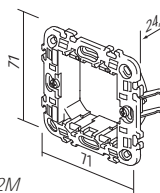

NOSILEC BREZ VIJAKOV 2M



NM21

- nosilec 2M brez vijakov in brez krepeljcev
- montaža v doze Ø60 (HE.., BE..) s vijaki
- možno horizontalno ali vertikalno nizanje 2x2M, 3x2M in 4x2M
- primeren za sestavo z okvirji LINE in SOFT
- ustreza EN 60669-1

MOUNTING FRAME WITHOUT SCREWS 2M

- mounting frame 2M without screws and without claws
- for mounting on boxes Ø60 (HE.., BE..) with screws
- possible horizontal or vertical combinations 2x2M, 3x2M and 4x2M
- suitable for assembling with cover plates LINE and SOFT
- in accordance with EN 60669-1

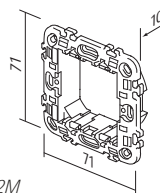

NOSILEC KOVINSKI S KREPELJCI 2M

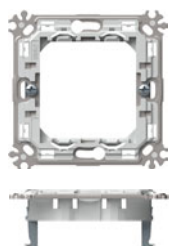

NM24

- kovinski nosilec 2M s krepeljci - toga izvedba
- montaža v doze Ø60 (DE..) s krepeljci
- možno horizontalno ali vertikalno nizanje 2x2M, 3x2M in 4x2M
- primeren za sestavo z okvirji PURE, LINE in SOFT
- ustreza EN 60669-1

MOUNTING FRAME METAL WITH CLAWS 2M

- metal mounting frame 2M with claws - stiff version
- for mounting on boxes Ø60 (DE..) with claws
- possible horizontal or vertical combinations 2x2M, 3x2M and 4x2M
- suitable for assembling with cover plates PURE, LINE and SOFT
- in accordance with EN 60669-1

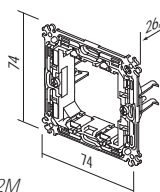

NOSILEC KOVINSKI BREZ VIJAKOV 2M



NM25

- kovinski nosilec brez vijakov in brez krepeljcev - toga izvedba
- montaža v doze Ø60 (HE.., BE..) s krepeljci
- možno horizontalno ali vertikalno nizanje 2x2M, 3x2M in 4x2M
- primeren za sestavo z okvirji PURE, LINE in SOFT
- ustreza EN 60669-1

MOUNTING FRAME METAL WITHOUT SCREWS 2M

- metal mounting frame 2M without screws and without claws - stiff version
- for mounting on boxes Ø60 (HE.., BE..) with claws
- possible horizontal or vertical combinations 2x2M, 3x2M and 4x2M
- suitable for assembling with cover plates PURE, LINE and SOFT
- in accordance with EN 60669-1

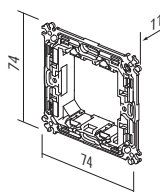

M O U N T I N G F R A M E S N M



NM30

NOSILEC Z VIJAKI 3M

- nosilec 3M z vijaki
- montaža v pravokotne doze velikosti 3M
- primeren za sestavo z okvirji PURE, LINE in SOFT
- ustreza EN 60669-1

MOUNTING FRAME WITH SCREWS 3M

- mounting frame 3M with screws
- for mounting on rectangular boxes 3M
- suitable for assembling with cover plates PURE, LINE and SOFT
- in accordance with EN 60669-1

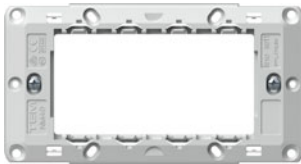
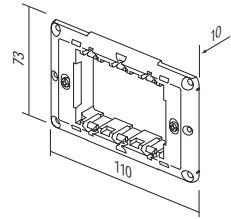

NM40

NOSILEC Z VIJAKI 4M

- nosilec 4M z vijaki
- montaža v pravokotne doze velikosti 4M
- primeren za sestavo z okvirji PURE, LINE in SOFT
- ustreza EN 60669-1

MOUNTING FRAME WITH SCREWS 4M

- mounting frame 4M with screws
- for mounting on rectangular boxes 4M
- suitable for assembling with cover plates PURE, LINE and SOFT
- in accordance with EN 60669-1

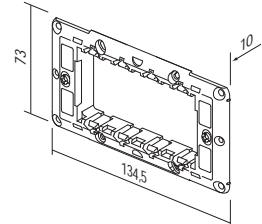

NM70

NOSILEC Z VIJAKI 7M

- nosilec 7M z vijaki
- montaža v pravokotne doze velikosti 7M
- primeren za sestavo z okvirji PURE, LINE in SOFT
- ustreza EN 60669-1

MOUNTING FRAME WITH SCREWS 7M

- mounting frame 7M with screws
- for mounting on rectangular boxes 7M
- suitable for assembling with cover plates PURE, LINE and SOFT
- in accordance with EN 60669-1

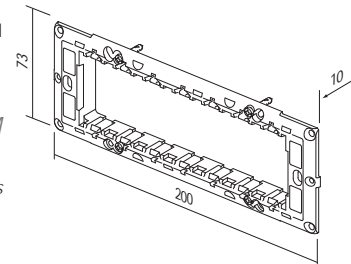

NM72

NOSILEC Z VIJAKI 2x7M

- nosilec 2x7M z vijaki
- montaža v pravokotne doze velikosti 2x7M
- primeren za sestavo z okvirjem SOFT OS72
- ustreza EN 60669-1

MOUNTING FRAME WITH SCREWS 2x7M

- mounting frame 2x7M with screws
- for mounting on rectangular boxes 2x7M
- suitable for assembling with cover plate SOFT OS72
- in accordance with EN 60669-1

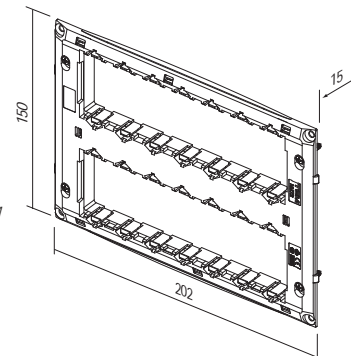



NM10

NOSILEC S KREPELJCI 1/2M

- nosilec 1/2M s krepeljci
- montaža v doze Ø60 (DE..) s krepeljci
- primeren za sestavo z okvirji LINE in SOFT
- ustreza EN 60669-1

MOUNTING FRAME WITH CLAWS 1/2M

- mounting frame 1/2M with claws
- for mounting on boxes Ø60 (DE..) with claws
- suitable for assembling with cover plates LINE and SOFT
- in accordance with EN 60669-1

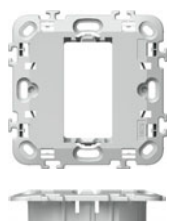
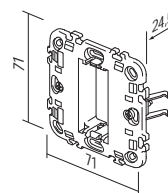

NM11

NOSILEC BREZ VIJAKOV 1/2M

- nosilec 1/2M brez vijakov in brez krepeljcev
- montaža v doze Ø60 (HE.., BE..) z vijaki
- primeren za sestavo z okvirji LINE in SOFT
- ustreza EN 60669-1

MOUNTING FRAME WITHOUT SCREWS 1/2M

- mounting frame 1/2M without screws and without claws
- for mounting on boxes Ø60 (HE.., BE..) with screws
- suitable for assembling with cover plates LINE and SOFT
- in accordance with EN 60669-1

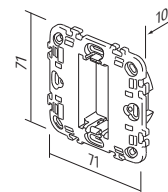

NM23

NOSILEC S KREPELJCI 2/3M

- nosilec 2/3M s krepeljci
- montaža v doze Ø60 (DE..) s krepeljci
- primeren za sestavo z okvirji PURE, LINE in SOFT
- ustreza EN 60669-1

MOUNTING FRAME WITH CLAWS 2/3M

- mounting frame 2/3M with claws
- for mounting on boxes Ø60 (DE..) with claws
- suitable for assembling with cover plates PURE, LINE and SOFT
- in accordance with EN 60669-1

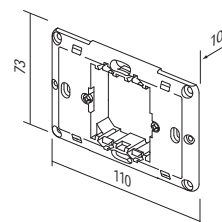

NM32

NOSILEC Z VIJAKI 2/3M

- nosilec 2/3M z vijaki
- montaža v pravokotne doze velikosti 3M
- primeren za sestavo z okvirji PURE, LINE in SOFT
- ustreza EN 60669-1

MOUNTING FRAME WITH SCREWS 2/3M

- mounting frame 2/3M with screws
- for mounting on rectangular boxes 3M
- suitable for assembling with cover plates PURE, LINE and SOFT
- in accordance with EN 60669-1

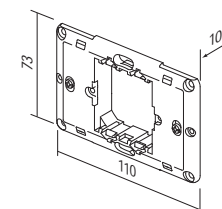

TEM

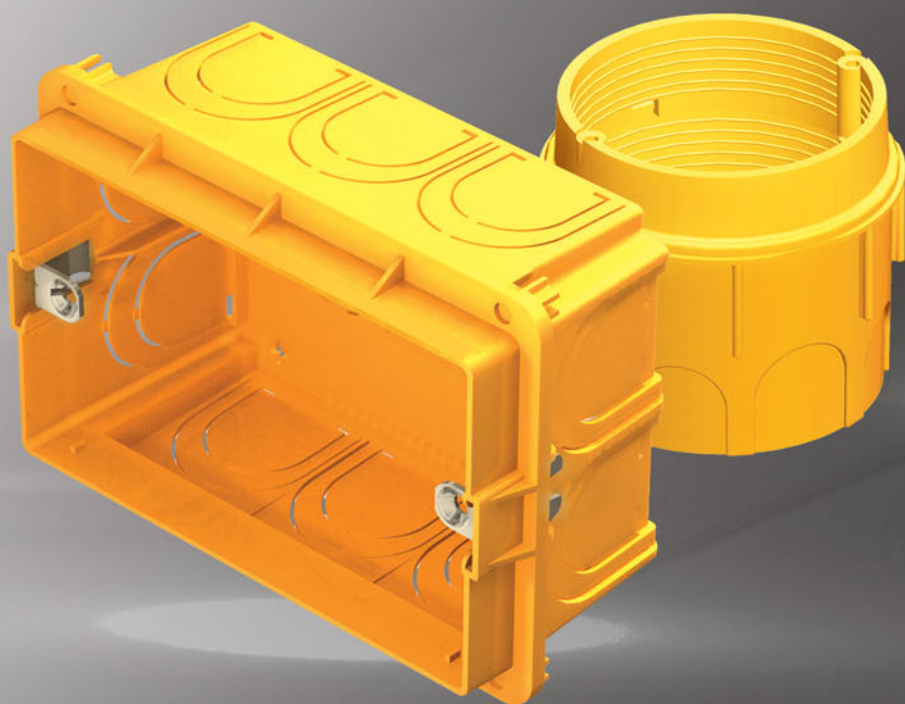



OKROGLE DOZE
ROUND BOXES



124

PRAVOKOTNE DOZE
RECTANGULAR BOXES



132

RAZVODNE DOZE
JUNCTION BOXES

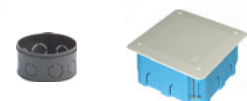

140

PRIBOR ZA OŽIČENJE
WIRING ACCESSORIES



142

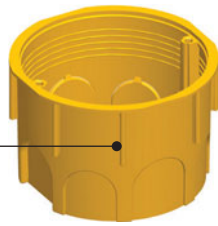

DE12



HE11

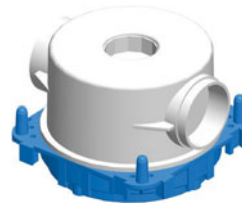

BE10

tip type	naziv description	velikost size
DE10	DOZA OKROGLA ZA ZID ROUND BOX BRICK	SM60-01
HE10	DOZA OKROGLA ZA VOTLE STENE ROUND BOX HOLLOW WALL	SM68X40
BE10	DOZA OKROGLA ZA BETON ROUND BOX CONCRETE	
.	.	.
.	.	.

DOZA OKROGLA ZA ZID SM60-01



DE10

- Ø60, globina 40mm
- 650°C, 500V~
- ustreza IEC 60670-1
- "halogen free"
ROUND BOX BRICK SM60-01
- Ø60, depth 40mm
- 650°C, 500V~
- in accordance with IEC 60670-1
- halogen free

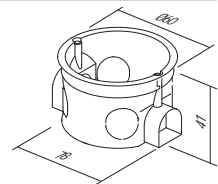

DOZA OKROGLA ZA ZID GLOBOKA SM60-06



DE11

- Ø60, globina 60mm
- 650°C, 500V~
- ustreza IEC 60670-1
- "halogen free"
ROUND BOX BRICK DEEP SM60-06
- Ø60, depth 60mm
- 650°C, 500V~
- in accordance with IEC 60670-1
- halogen free

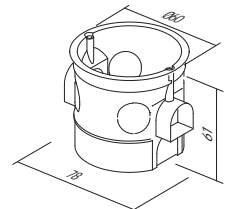

VEZNI ČLEN DOZE ZA ZID SM60-03



DE30

- za vertikalno povezavo doz SM60-06 ali SM60-01 na razdaljo 91 mm
- ustreza IEC 60670-1
- "halogen free"
COMBI-CLIP SM60-03
- for vertical fitting of boxes SM60-06 or SM60-01 on distance 91 mm
- in accordance with IEC 60670-1
- halogen free

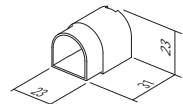

VEZNI ČLEN DOZE ZA ZID SM60-04



DE31

- za horizontalno povezavo doz SM60-06 ali SM60-01 na razdaljo 71mm
- ustreza IEC 60670-1
- "halogen free"
COMBI-CLIP SM60-04
- for horizontal fitting of boxes SM60-06 or SM60-01 on distance 71mm
- in accordance with IEC 60670-1
- halogen free

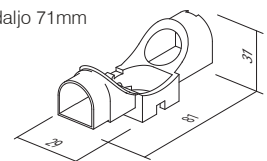

DOZA OKROGLA ZA ZID MD65-46



DE12

- Ø65, globina 46mm
- 650°C, 500V~
- ustreza IEC 60670-1

ROUND BOX BRICK MD65-46

- Ø65, depth 46mm
- 650°C, 500V~
- in accordance with IEC 60670-1

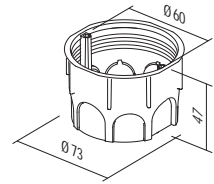

DOZA OKROGLA ZA ZID GLOBOKA MD65-60

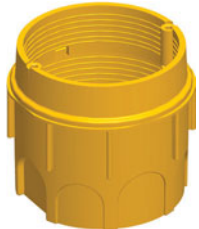

DE13

- Ø65/60, globina 62mm
- 650°C, 500V~
- ustreza IEC 60670-1

ROUND BOX BRICK DEEP MD65-60

- Ø65/60, depth 62mm
- 650°C, 500V~
- in accordance with IEC 60670-1

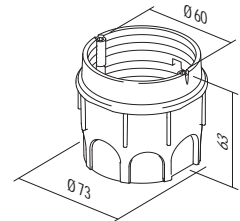

PODALJŠEK DOZE ZA ZID MD65-46

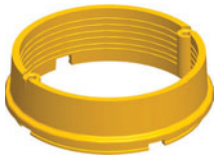

DE14

- Ø65/60, globina 17mm
- 650°C, 500V~
- ustreza IEC 60670-1

ADDITIONAL PIECE FOR MD65-46

- Ø65/60, depth 17mm
- 650°C, 500V~
- in accordance with IEC 60670-1

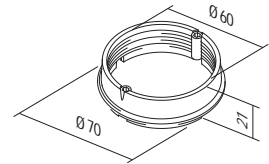

VEZNI ČLEN DOZE ZA ZID MD65-71



DE32

- za povezavo doz MD65 na razdaljo 71 mm
- ustreza IEC 60670-1

COMBI-CLIP MD65-71

- for fitting of boxes MD65 on distance 71 mm
- in accordance with IEC 60670-1

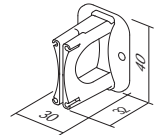

VEZNI ČLEN DOZE ZA ZID MD65-91



DE33

- za povezavo doz MD65 na razdaljo 91mm
- ustreza IEC 60670-1

COMBI-CLIP MD65-91

- for fitting of boxes MD65 on distance 91mm
- in accordance with IEC 60670-1

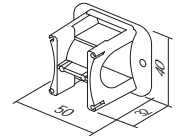

POKROV DOZE ZAŠČITNI 60



DE20

- zaščitni pokrov doze Ø60 za DE13, DE14
- ustreza IEC 60670-1
- za zaščito pri ometavanju

BOX COVER PROTECTIVE 60

- protective cover for box Ø60 for DE13, DE14
- in accordance with IEC 60670-1
- box protection during plastering

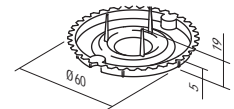

POKROV DOZE ZAŠČITNI 65



DE21

- zaščitni pokrov doze Ø65 za DE12
- ustreza IEC 60670-1
- za zaščito pri ometavanju

BOX COVER PROTECTIVE 65

- protective cover for box Ø65 for DE12
- in accordance with IEC 60670-1
- box protection during plastering

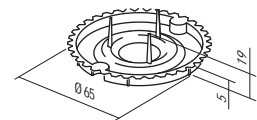

POKROV DOZE DEKORATIVNI SM60



DE22

- dekorativni pokrov doze Ø60
- ustreza IEC 60670-1
- "halogen free"

BOX COVER DECORATIVE SM60

- decorative cover for boxes Ø60
- in accordance with IEC 60670-1
- halogen free

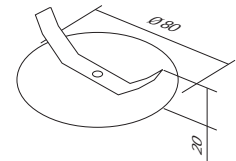



opeka / brick

navodila za montažo /
assembly instructions

razdalja med dozami / distance between boxes: 71mm

razdalja med dozami / distance between boxes: 91mm

D O Z E

DE10,11

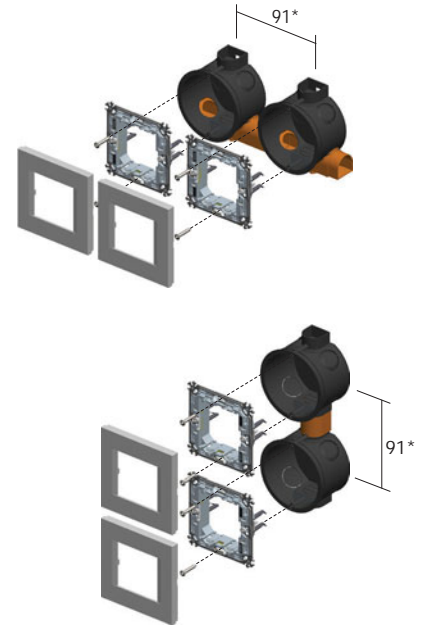
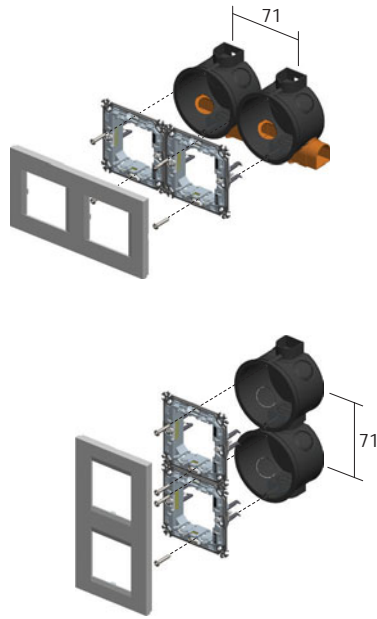
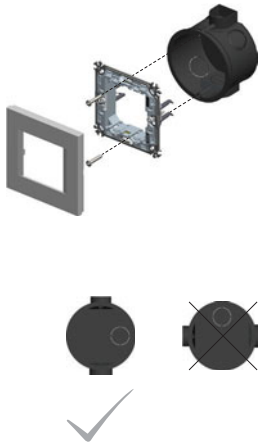

DE12,13

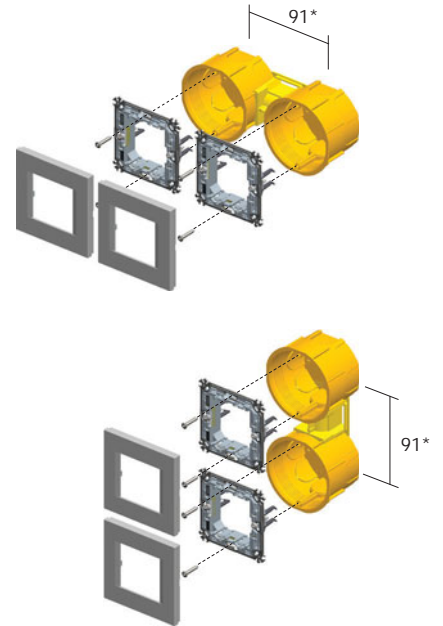
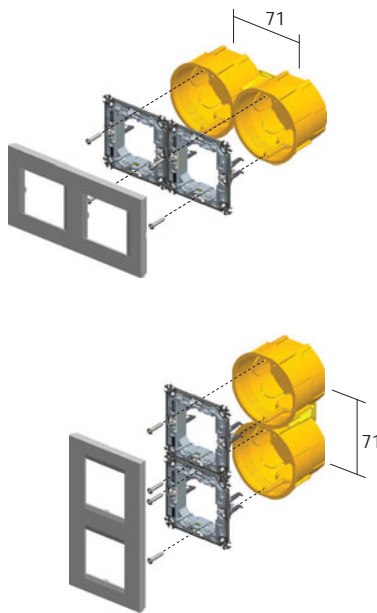
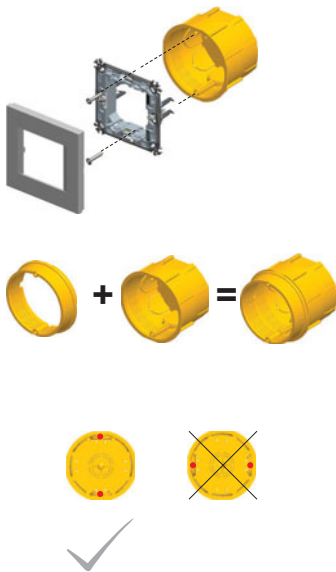

* za okvirje PURE je min. razdalja me dozami 100mm
* for PURE cover plates the minimum distance between boxes is 100mm

R O U N D B O X E S



DE10,11



NM20



DE12,13



NM24



DE10,11



NM10



DE12,13



71

2xDE10,11 + 2xDE31



2xNM20



2xDE12,13 + 1xDE32



2xNM24



DE10,11



NM23



DE12,13



2xDE10,11 2xDE12,13 + 1xDE32



2xNM20



2xNM24



3xDE10,11 + 3xDE31



3xNM20



3xDE12,13 + 2xDE32



3xNM24



3xDE10,11 3xDE12,13 + 2xDE32

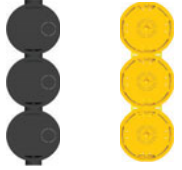

3xNM20



3xNM24



4xDE10,11 + 4xDE31



4xNM20



4xDE12,13 + 3xDE32



4xNM24



4xDE10,11 4xDE12,13 + 3xDE32

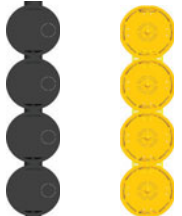

4xNM20



4xNM24



DOZA OKROGLA ZA VOTLE STENE SM68x40



HE10

- Ø60, globina 40mm
- vgradnja v izvrtino Ø68
- 850°C, 400V~
- ustreza IEC 60670-1
- montaža s krepeljci
- "halogen free"

ROUND BOX HOLLOW WALL SM68x40

- Ø60, depth 40mm
- cutting hole Ø68
- 850°C, 400V~
- in accordance with IEC 60670-1
- mounting with claws
- halogen free

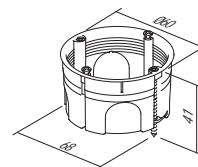

DOZA OKROGLA ZA VOTLE STENE SM68x55



HE11

- Ø60, globina 55mm
- vgradnja v izvrtino Ø68
- 850°C, 400V~
- ustreza IEC 60670-1
- montaža s krepeljci
- "halogen free"

ROUND BOX HOLLOW WALL SM68x55

- Ø60, depth 55mm
- cutting hole Ø68
- 850°C, 400V~
- in accordance with IEC 60670-1
- mounting with claws
- halogen free

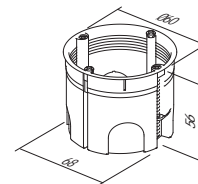

DOZA OKROGLA ZA BETON

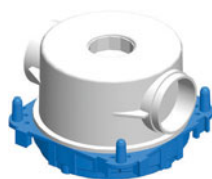

BE10

- Ø60mm, globina 49mm
- 650°C, 500V~
- ustreza IEC 60670-1

ROUND BOX CONCRETE

- Ø60mm, depth 49mm
- 650°C, 500V~
- in accordance with IEC 60670-1

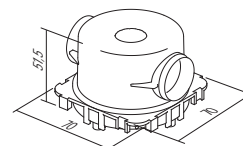

DOZA OKROGLA ZA BETON GOLOBOKA



BE11

- Ø60mm, globina 58mm
- 650°C, 500V~
- ustreza IEC 60670-1

ROUND BOX CONCRETE DEEP

- Ø60mm, depth 58mm
- 650°C, 500V~
- in accordance with IEC 60670-1

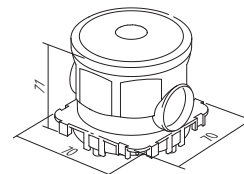

NOSILEC DOZE ZA BETON



BE20

- za utrditev doze z distančnim profilom BM82 v nasprotno steno
- ustreza IEC 60670-1

COUNTER BOX SUPPORT CONCRETE

- to support concrete boxes with distance profile BM82 for extreme loads
- in accordance with IEC 60670-1

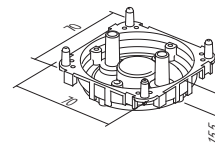

UVODNICA DOZE ZA BETON 16



BE21

- za utrditev instalacijske cevi
- ustreza IEC 60670-1

PIPE STOPPER CONCRETE BOX 16

- for firming installation pipe to box
- in accordance with IEC 60670-1

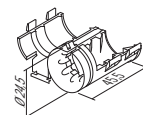

R O U N D B O X E S



 votle stene / hollow walls





 beton / concrete



navodila za montažo /
assembly instructions

razdalja med dozami / distance between boxes: 71mm

razdalja med dozami / distance between boxes: 91mm

HE10,11

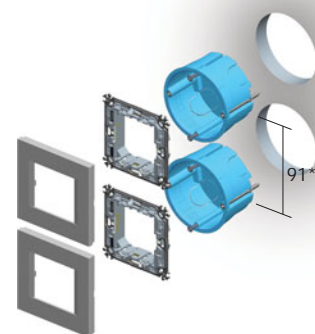
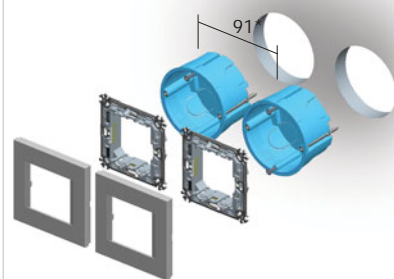
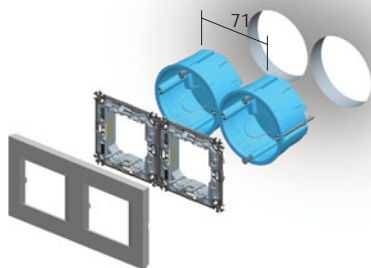
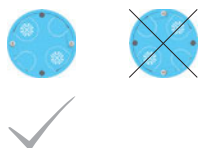
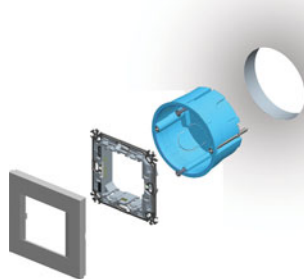

BE10

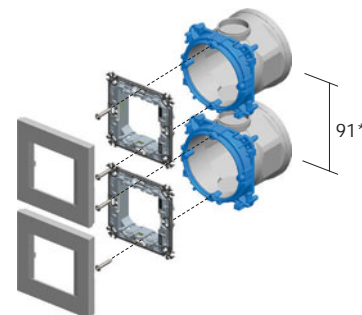
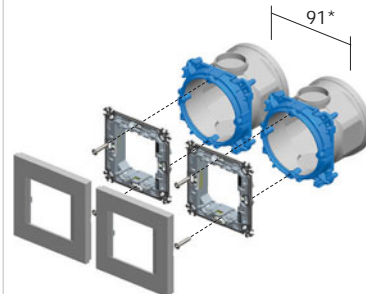
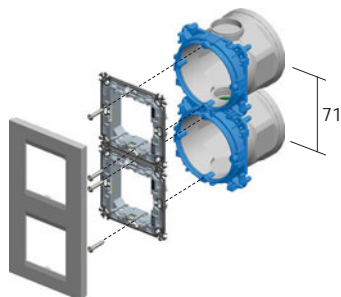
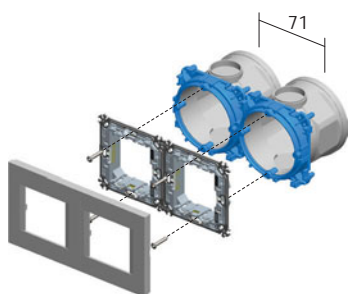
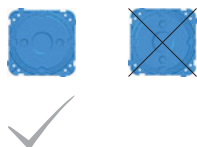
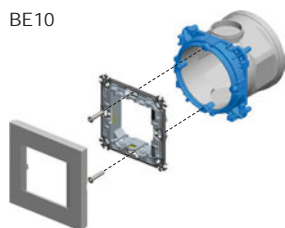

* za okvirje PURE je min. razdalja me dozami 100mm

* for PURE cover plates the minimum distance between boxes is 100mm

votle stene / hollow walls



beton / concrete

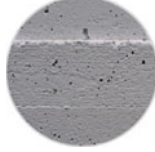

HE10,11



BE10,11



NM21



NM25



2M

HE10,11



BE10,11



NM11



1/2M

2xHE10,11



2xBE10,11



2xNM21



2xNM25



2x2M

HE10,11



BE10,11



NM32



2/3M

2xHE10,11



2xBE10,11



2xNM21



2xNM25



3xHE10,11



3xBE10,11



3xNM21



3xNM25



3x2M

3xHE10,11



3xBE10,11



3xNM21



3xNM25



4xHE10,11



4xBE10,11



4xNM21



4xNM25



4x2M

4xHE10,11



4xBE10,11



4xNM21



4xNM25



R O U N D B O X E S

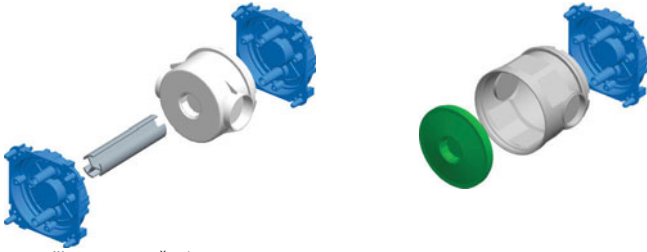

navodila za montažo /
assembly instructions

1

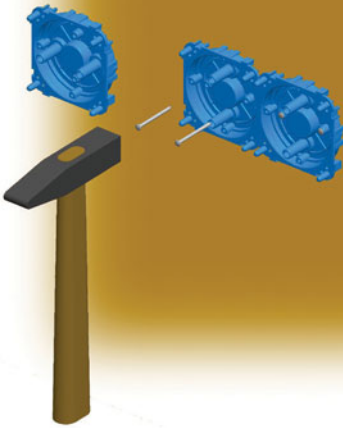

2

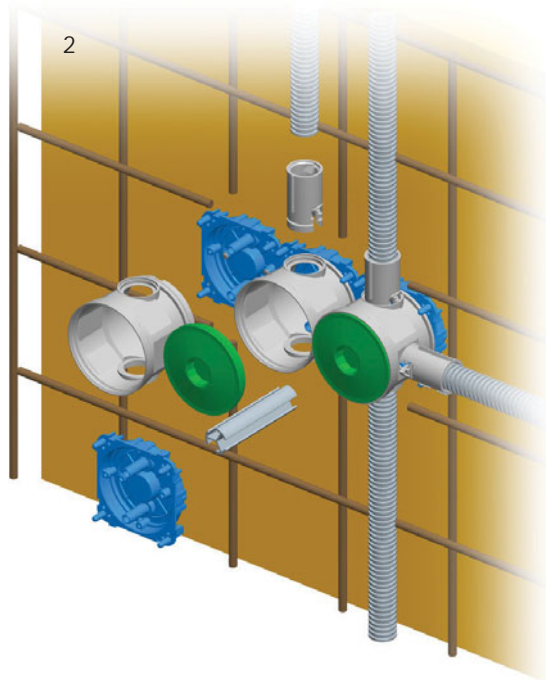

3

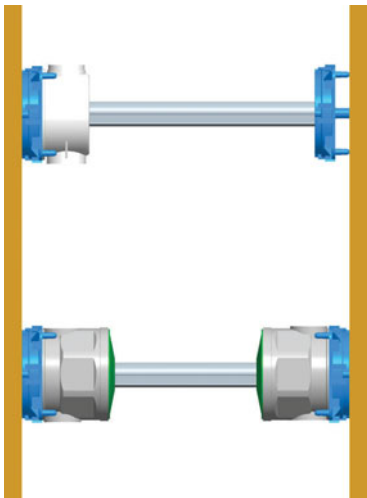

4

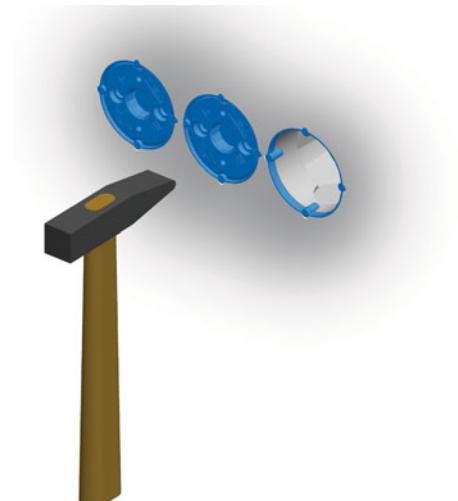

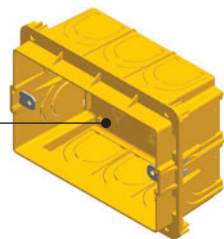

DM30



HM30

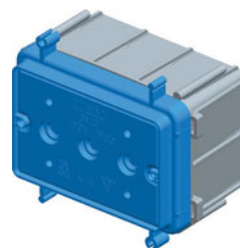

BM30

tip type	naziv description	velikost size
DM30	DOZA PRAVOKOTNA ZA ZID <i>RECTANGULAR BOX BRICK</i>	PM3
HM30	DOZA PRAVOKOTNA ZA VOTLE STENE <i>RECTANGULAR BOX HOLLOW WALL</i>	VM3
BM30	DOZA PRAVOKOTNA ZA BETON <i>RECTANGULAR BOX CONCRETE</i>	BM3
.	.	.
.	.	.

DOZA PRAVOKOTNA ZA ZID PM3



DM30

- velikost 3M, globina 49mm
- 650°C, 400V~
- ustreza IEC 60670-1
- "halogen free"

RECTANGULAR BOX BRICK PM3

- size 3M, depth 49mm
- 650°C, 400V~
- in accordance with IEC 60670-1
- halogen free

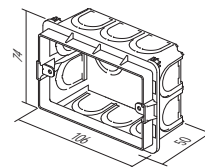

DOZA PRAVOKOTNA ZA ZID PM3-65

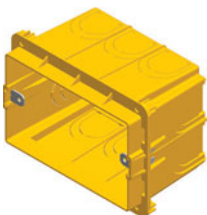

DM31

- velikost 3M, globina 65mm
- 650°C, 400V~
- ustreza IEC 60670-1
- "halogen free"

RECTANGULAR BOX BRICK PM3-65

- size 3M, depth 65mm
- 650°C, 400V~
- in accordance with IEC 60670-1
- halogen free

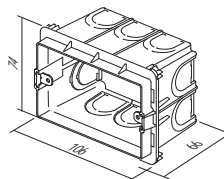

DOZA PRAVOKOTNA ZA ZID PM4



DM40

- velikosti 4M, globina 49mm
- 650°C, 400V~
- ustreza IEC 60670-1
- "halogen free"

RECTANGULAR BOX BRICK PM4

- size 4M, depth 49mm
- 650°C, 400V~
- in accordance with IEC 60670-1
- halogen free

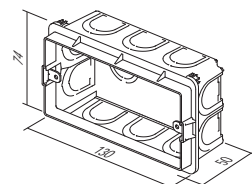

DOZA PRAVOKOTNA ZA ZID PM4-65

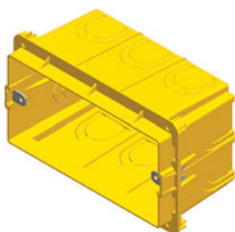

DM41

- velikosti 4M, globina 65mm
- 650°C, 400V~
- ustreza IEC 60670-1
- "halogen free"

RECTANGULAR BOX BRICK PM4-65

- size 4M, depth 65mm
- 650°C, 400V~
- in accordance with IEC 60670-1
- halogen free

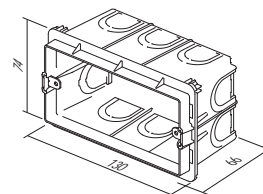

DOZA PRAVOKOTNA ZA ZID PM7

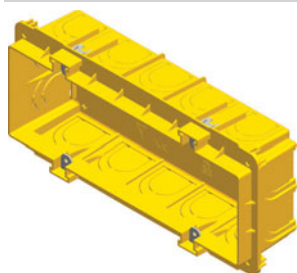

DM70

- velikost 7M, globina 49mm
- 650°C, 400V~
- ustreza IEC 60670-1
- "halogen free"

RECTANGULAR BOX BRICK PM7

- size 7M, depth 49mm
- 650°C, 400V~
- in accordance with IEC 60670-1
- halogen free

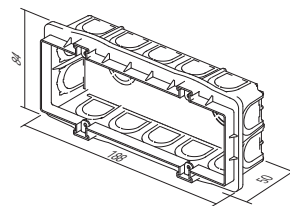

DOZA PRAVOKOTNA ZA ZID PM7-65

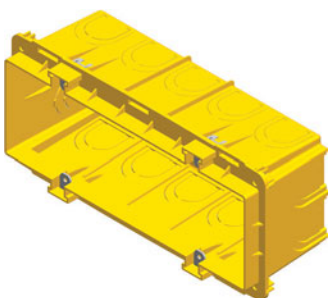

DM71

- velikost 7M, globina 65mm
- 650°C, 400V~
- ustreza IEC 60670-1
- "halogen free"

RECTANGULAR BOX BRICK PM7-65

- size 7M, depth 65mm
- 650°C, 400V~
- in accordance with IEC 60670-1
- halogen free

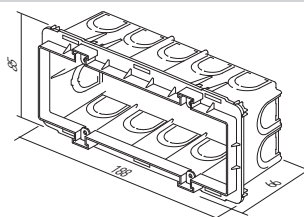

DOZA PRAVOKOTNA ZA ZID PM72-65



DM72

- velikost 2x7M, globina 64mm
- 650°C, 400V~
- ustreza IEC 60670-1

RECTANGULAR BOX BRICK PM72-65

- size 2x7M, depth 64mm
- 650°C, 400V~
- in accordance with IEC 60670-1

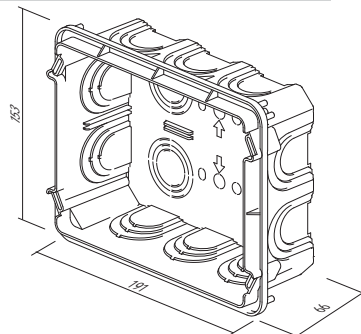

VEZNI ČLEN DOZE PM

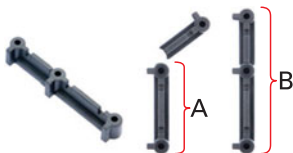

DM80

- za vertikalno (B) in horizontalno (A) sestavo
- doz PM3, PM4 in PM7

DISTANCE PIECE FOR BOX PM

- for vertical (B) and horizontal (A) fitting of boxes
- PM3, PM4 and PM7

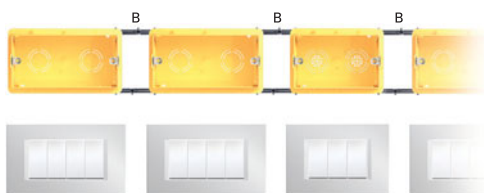
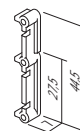



DM33

POKROV DOZE ZAŠČITNI PM3

- zaščitni pokrov doze PM3
- ustreza IEC 60670-1
- "halogen free"
- za zaščito pri ometavanju

BOX COVER PROTECTIVE PM3

- protective cover for box PM3
- in accordance with IEC 60670-1
- halogen free
- box protection during plastering

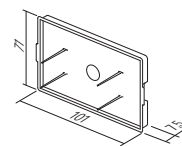

DM34

POKROV DOZE DEKORATIVNI PM3

- dekorativni pokrov doze 3M
- vijaka priložena
- ustreza IEC 60670-1
- "halogen free"

BOX COVER DECORATIVE PM3

- decorative cover for boxes 3M
- screws are included
- in accordance with IEC 60670-1
- halogen free

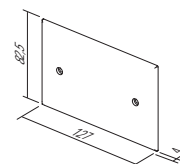

DM43

POKROV DOZE ZAŠČITNI PM4

- zaščitni pokrov doze PM4
- ustreza IEC 60670-1
- "halogen free"
- za zaščito pri ometavanju

BOX COVER PROTECTIVE PM4

- protective cover for box PM4
- in accordance with IEC 60670-1
- halogen free
- box protection during plastering

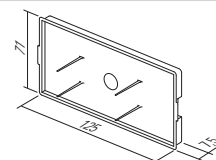

DM44

POKROV DOZE DEKORATIVNI PM4

- dekorativni pokrov doze 4M
- vijaka priložena
- ustreza IEC 60670-1
- "halogen free"

BOX COVER DECORATIVE PM4

- decorative cover for boxes 4M
- screws are included
- in accordance with IEC 60670-1
- halogen free

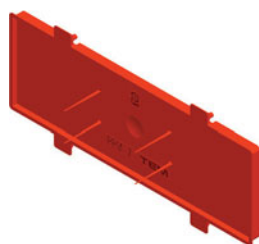
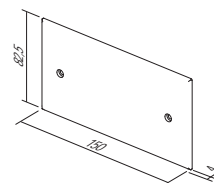

DM73

POKROV DOZE ZAŠČITNI PM7

- zaščitni pokrov doze PM7
- ustreza IEC 60670-1
- "halogen free"
- za zaščito pri ometavanju

BOX COVER PROTECTIVE PM7

- protective cover for box PM7
- in accordance with IEC 60670-1
- halogen free
- box protection during plastering

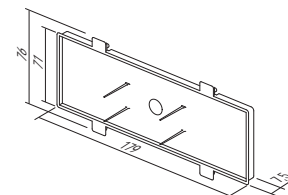

DM74

POKROV DOZE DEKORATIVNI PM7

- dekorativni pokrov doze 7M
- vijaka priložena
- ustreza IEC 60670-1
- "halogen free"

BOX COVER DECORATIVE PM7

- decorative cover for boxes 7M
- screws are included
- in accordance with IEC 60670-1
- halogen free

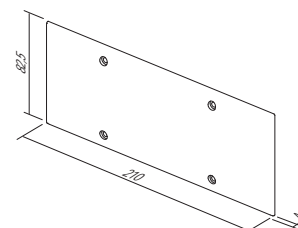



DM75

POKROV DOZE DEKORATIVNI PM72

- dekorativni pokrov doze 2x7M
- vijaki priloženi
- ustreza IEC 60670-1

BOX COVER DECORATIVE PM72

- decorative cover for boxes 2x7M
- screws are included
- in accordance with IEC 60670-1

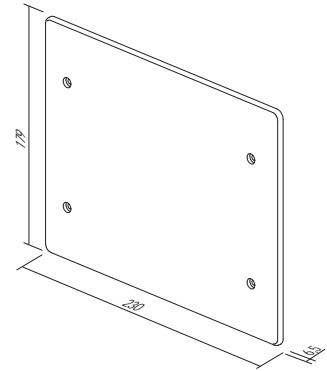

DOZA PRAVOKOTNA ZA VOTLE STENE VM3



HM30

- velikost 3M, globina 49mm
- vgradnja v izvrtino 2xØ68/45mm
- 850°C, 400V~
- ustreza IEC 60670-1
- "halogen free"

RECTANGULAR BOX HOLLOW WALL VM3

- size 3M, depth 49mm
- cutting hole 2xØ68/45mm
- 850°C, 400V~
- in accordance with IEC 60670-1
- halogen free

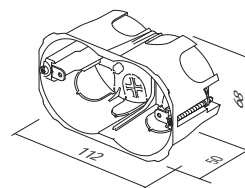

DOZA PRAVOKOTNA ZA VOTLE STENE VM4



HM40

- velikost 4M, globina 49mm
- vgradnja v izvrtino 2xØ68/70mm
- 850°C, 400V~
- ustreza IEC 60670-1
- "halogen free"

RECTANGULAR BOX HOLLOW WALL VM4

- size 4M, depth 49mm
- cutting hole 2xØ68/70mm
- 850°C, 400V~
- in accordance with IEC 60670-1
- halogen free

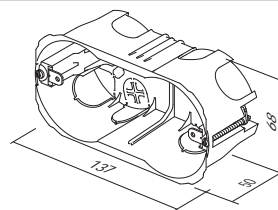

DOZA PRAVOKOTNA ZA VOTLE STENE VM7



HM70

- velikost 7M, globina 49mm
- vgradnja v izvrtino 2xØ68/120mm
- 850°C, 400V~
- ustreza IEC 60670-1
- "halogen free"

RECTANGULAR BOX HOLLOW WALL VM7

- size 7M, depth 49mm
- cutting hole 2xØ68/120mm
- 850°C, 400V~
- in accordance with IEC 60670-1
- halogen free

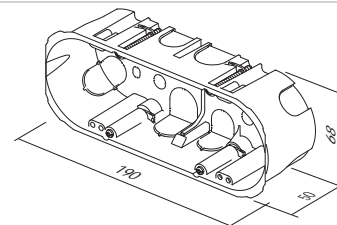

DOZA PRAVOKOTNA ZA VOTLE STENE VM72



HM72

- velikost 2x7M, globina 63mm
- 850°C, 400V~
- ustreza IEC 60670-1

RECTANGULAR BOX HOLLOW WALL VM72

- size 2x7M, depth 63mm
- 850°C, 400V~
- in accordance with IEC 60670-1

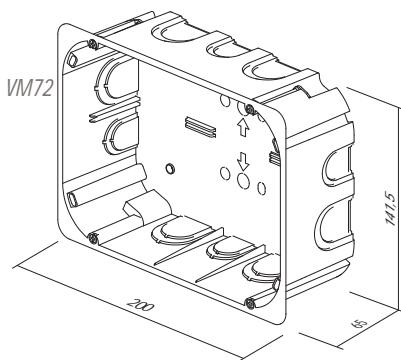

R E C T A N G U L A R B O X E S

DOZA PRAVOKOTNA ZA BETON BM3



BM30

- velikost 3M, globina 60mm
- 650°C, 400V~
- ustreza IEC 60670-1

RECTANGULAR BOX CONCRETE BM3

- size 3M, depth 60mm
- 650°C, 400V~
- in accordance with IEC 60670-1

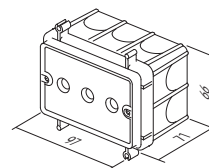

DOZA PRAVOKOTNA ZA BETON BM4

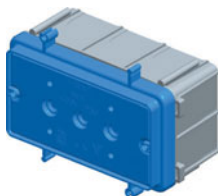

BM40

- velikost 4M, globina 60mm
- 650°C, 400V~
- ustreza IEC 60670-1

RECTANGULAR BOX CONCRETE BM4

- size 4M, depth 60mm
- 650°C, 400V~
- in accordance with IEC 60670-1

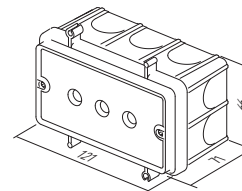

DOZA PRAVOKOTNA ZA BETON BM7

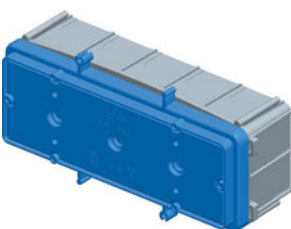

BM70

- velikost 7M, globina 60mm
- 650°C, 400V~
- ustreza IEC 60670-1

RECTANGULAR BOX CONCRETE BM7

- size 7m, depth 60mm
- 650°C, 400V~
- in accordance with IEC 60670-1

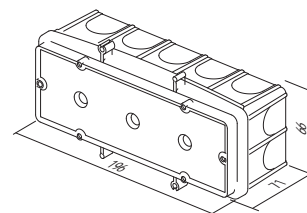

PRITRDLNI ČLEN DOZ BM



BM80

- za hitro pritrditev pravokotnih doz BM na armaturno mrežo
- primerno za palice do premera Ø8mm

FIXING COMBI-CLIP BM

- for fast fixation of BM rectangular boxes on reinforcing bar
- suitable for bar diameter up to Ø8mm

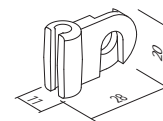

DISTRANČNI PROFIL ZA DOZE

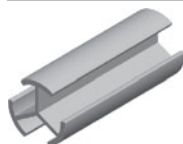

BM82

- za utrditev doz BM skupaj z nosilcem doze za beton v nasprotno steno
- dolžina l=1m, premer Ø20mm

DISTANCE PROFIL FOR BOXES BM

- to support boxes BM with counter box support on opposite wall
- length l=1m, diameter Ø20mm

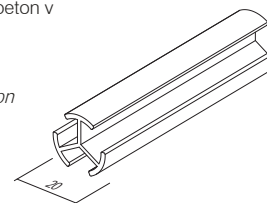



opeka / brick



votle stene / hollow walls



beton / concrete

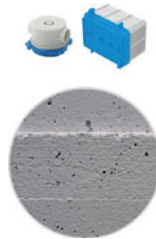

D O Z E

DM30   **3M**

HM30  

BM30 

DM40   **4M**

HM40  

BM40 

DM70   **7M**

HM70  

BM70 

DM72   **2x7M**

HM72 

DM30   **2/3M**

HM30  

BM30 

R E C T A N G U L A R B O X E S

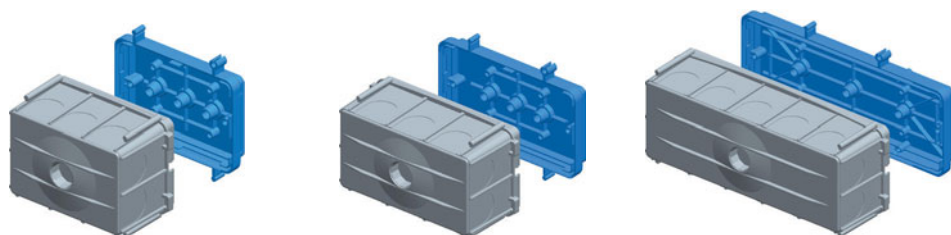

navodila za montažo /
assembly instructions

1

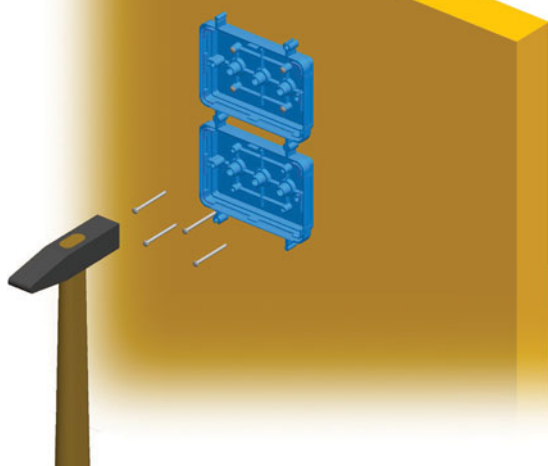

2

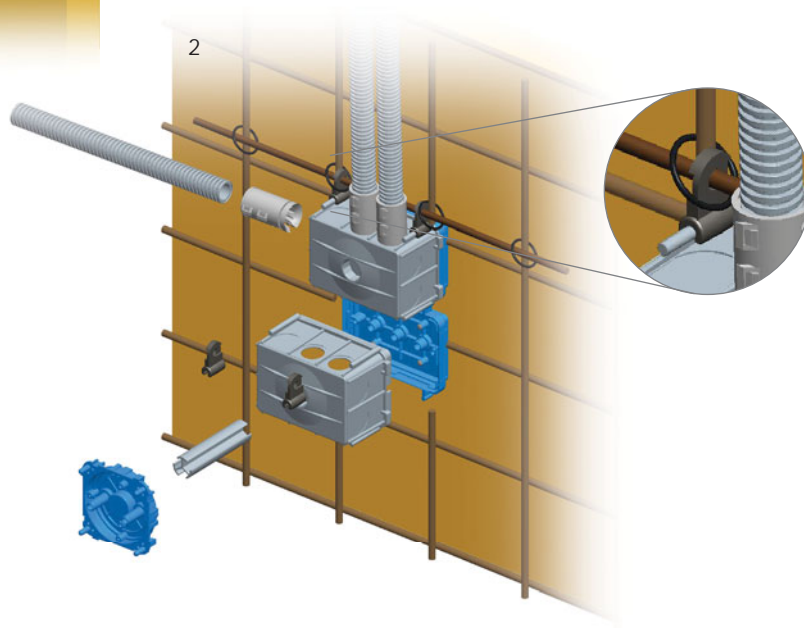

3

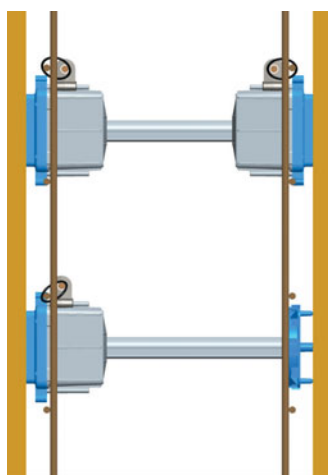

4

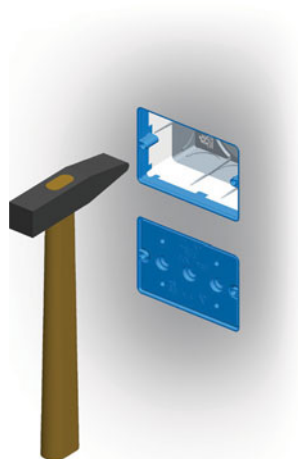



DW10

RAZVODNA DOZA OKROGLA ZA ZID DSM78

- Ø78, globina 40mm
- 650°C, 500V~
- ustreza IEC 60670-1 in IEC 60670-22
- "halogen free"

CONNECTION ROUND BOX BRICK DSM78

- Ø78, depth 40mm
- 650°C, 500V~
- in accordance with IEC 60670-1 and IEC 60670-22
- halogen free

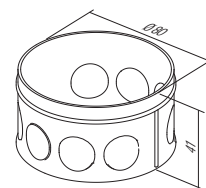

HW10

RAZVODNA DOZA OKROGLA ZA VOTLE STENE SM78x45

- Ø78, globina 45mm
- vgradnja v izvrtino Ø80
- 850°C, 400V~
- ustreza IEC 60670-1 in IEC 60670-22
- montaža s krepeljci
- "halogen free"

CONNECTION ROUND BOX HOLLOW WALL SM78x45

- Ø78, depth 45mm
- cutting hole Ø80
- 850°C, 400V~
- in accordance with IEC 60670-1 and IEC 60670-22
- mounting with claws
- halogen free

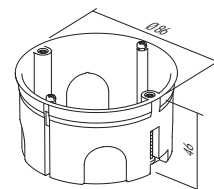

DE23

POKROV DOZE DEKORATIVNI SM78

- dekorativni pokrov doze Ø78
- ustreza IEC 60670-1 and IEC 60670-22
- "halogen free"

BOX COVER DECORATIVE SM78

- decorative cover for boxes Ø78
- in accordance with IEC 60670-1 and IEC 60670-22
- halogen free

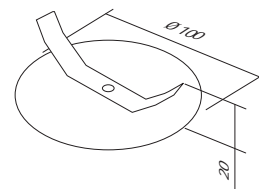

DE24

POKROV DOZE ZAŠČITNI 78

- zaščitni pokrov doze Ø78
- ustreza IEC 60670-1 in IEC 60670-22
- "halogen free"

BOX COVER PROTECTIVE 78

- protective cover for box Ø78
- in accordance with IEC 60670-1 and IEC 60670-22
- halogen free

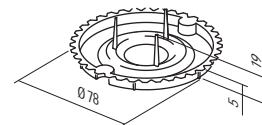

HW20

RAZVODNA DOZA KVADRATNA ZA ZID SM105x105

- 105x105mm, globina 50mm
- vgradnja v izvrtino s priloženo šablono
- 850°C, 400V~
- ustreza IEC 60670-1 in IEC 60670-22
- montaža s krepeljci
- "halogen free"

CONNECTION SQUARE BOX BRICK SM105x105

- size 105x105mm, depth 50mm
- cutting hole according to attached template
- 850°C, 400V~
- in accordance with IEC 60670-1 and IEC 60670-22
- mounting with claws
- halogen free

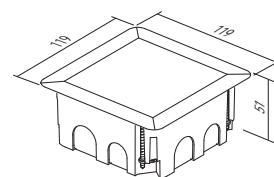

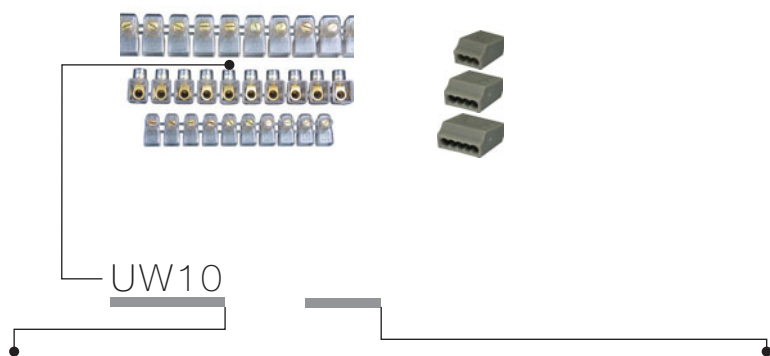

tip type	naziv description	tehnični opis technical data	velikost size	barva colour
UW10	ENOREDNE SPONKE ZAPRTE 1 ROW TERMINAL BLOCKS	2x2.5mm ²	10P	TS prozorna transparent
UW11	ENOREDNE SPONKE ZAPRTE 1 ROW TERMINAL BLOCKS	2x4mm ²	10P	CO barvne colour
UW12	ENOREDNE SPONKE ZAPRTE 1 ROW TERMINAL BLOCKS	2x6mm ²	10P	WH bela white
.	.	.	.	GY siva grey

ENOREDNE SPONKE ZAPRTE



- 450V~; 2x2.5mm² ÷ 2x6mm²
- termoplast PC, prozorne
- število polov: 10

1 ROW TERMINAL BLOCKS CLOSED

- 450V~; 2x2.5mm² ÷ 2x6mm²
- termoplast PC, transparent
- number of poles: 10

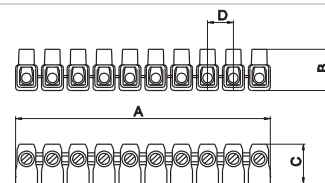

UW10TS	(NS12)	2x2.5mm ²	10P
UW11TS	(NS12)	2x4mm ²	10P
UW12TS	(NS12)	2x6mm ²	10P

	A	B	C	D
2x2.5 □	110	17.5	17.5	11
2x4 □	128	21	19	12.5
2x6 □	146	21.5	22	15

ENOREDNE SPONKE

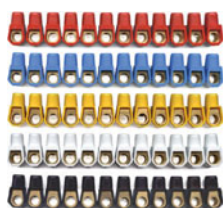

- 450V~; 2x2.5mm² ÷ 2x6mm²
- termoplast PA
- na voljo v različnih barvah
- število polov: 12

1 ROW TERMINAL BLOCKS

- 450V~; 2x2.5mm² ÷ 2x6mm²
- termoplast PA
- available in different colours
- number of poles: 12

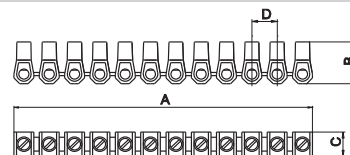

UW15CO	(NS12)	2x2.5mm ²	12P
UW16CO	(NS12)	2x4mm ²	12P
UW17CO	(NS12)	2x6mm ²	12P

	A	B	C	D
2x2.5 □	110	16.4	9	10
2x4 □	118.8	19	10	10
2x6 □	129.8	21.3	11	11.8

DVOREDNE SPONKE

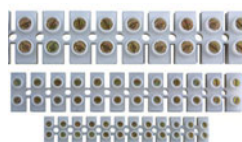

- 450V~; 1.5mm² ÷ 16mm²
- termoplast PA, bele
- število polov: 12

2 ROW TERMINAL BLOCKS

- 450V~; 1.5mm² ÷ 16mm²
- termoplast PA, white
- number of poles: 12

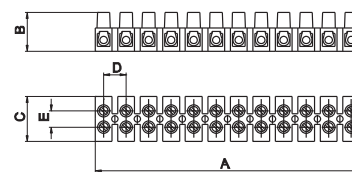

UW20WH	(P7)	2.5-4.0mm ²	12P
UW21WH	(P9)	4.0-6.0mm ²	12P
UW22WH	(P12)	6.0-10mm ²	12P
UW23WH	(P14)	16mm ²	12P

	A	B	C	D	E
1.5 □	119.5	17	20	10	8
2.5 □	118	17	20	10	8
4-6 □	129.2	19	22	11	8
10 □	147	23	25	12.5	9
16 □	177	29	30	15	13

**BREZVIJAČNE SPONKE**

- 24A 450V~, termoplast PA, sive
- število polov: 3÷8
- brezvijačni kontakti $0.5 \div 1.5\text{mm}^2$, za trde žice
- ustreza EN 60998-1

PLUG-IN WIRE CONNECTORS

- 24A 450V~, thermoplast PA, grey
- number of poles: 3÷8
- plug-in contacts $0.5 \div 1.5\text{mm}^2$, for rigide wires
- in accordance with EN 60998-1

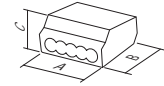

UW40GY	PC153	1.5mm ²	3P	3P	A	B	C
UW41GY	PC155	1.5mm ²	5P	5P	12	18	9
UW42GY	PC158	1.5mm ²	8P	8P	17	18	9
				8P	26	18	9

**BREZVIJAČNE SPONKE**

- 24A 450V~, termoplast PA, sive
- število polov: 3÷5
- brezvijačni kontakti $1.5 \div 2.5\text{mm}^2$, za trde žice
- ustreza EN 60998-1

PLUG-IN WIRE CONNECTORS

- 24A 450V~, thermoplast PA, grey
- number of poles: 3÷5
- plug-in contacts $1.5 \div 2.5\text{mm}^2$, for rigide wires
- in accordance with EN 60998-1

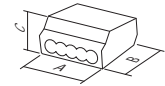

UW45GY	PC253	2.5mm ²	3P	3P	A	B	C
UW46GY	PC254	2.5mm ²	4P	4P	14	19	9
UW47GY	PC255	2.5mm ²	5P	5P	17	19	9
				5P	21	19	9

**BREZVIJAČNE SPONKE**

- 24A 450V~, termoplast PA, sive
- število polov: 2 (trda žica) + 1 (mehka žica)
- brezvijačni kontakti $1.5 \div 2.5\text{mm}^2$
- ustreza EN 60998-1

PLUG-IN WIRE CONNECTOR

- 24A 450V~, thermoplast PA, grey
- number of poles: 2 (rigide wire) + 1 (soft wire)
- plug-in contacts $1.5 \div 2.5\text{mm}^2$
- in accordance with EN 60998-1

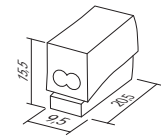

UW50WH	PC302	2.5mm ²	2/1P				
--------	-------	--------------------	------	--	--	--	--

TEM





OHIŠJA CUBO IP20 AC
BOXES CUBO IP20 AC



146

OHIŠJA CUBO IP55 AQ
BOXES CUBO IP55 AQ



147

PARAPETNI KANALI ALUMINIJSKI MA
TRUNKING SYSTEM ALUMINIUM MA



148

TALNE DOZE MT
FLOOR BOXES MT



153

RAZVODNE OMARICE MO
DISTRIBUTION BOARDS MO



156

AC21

PW

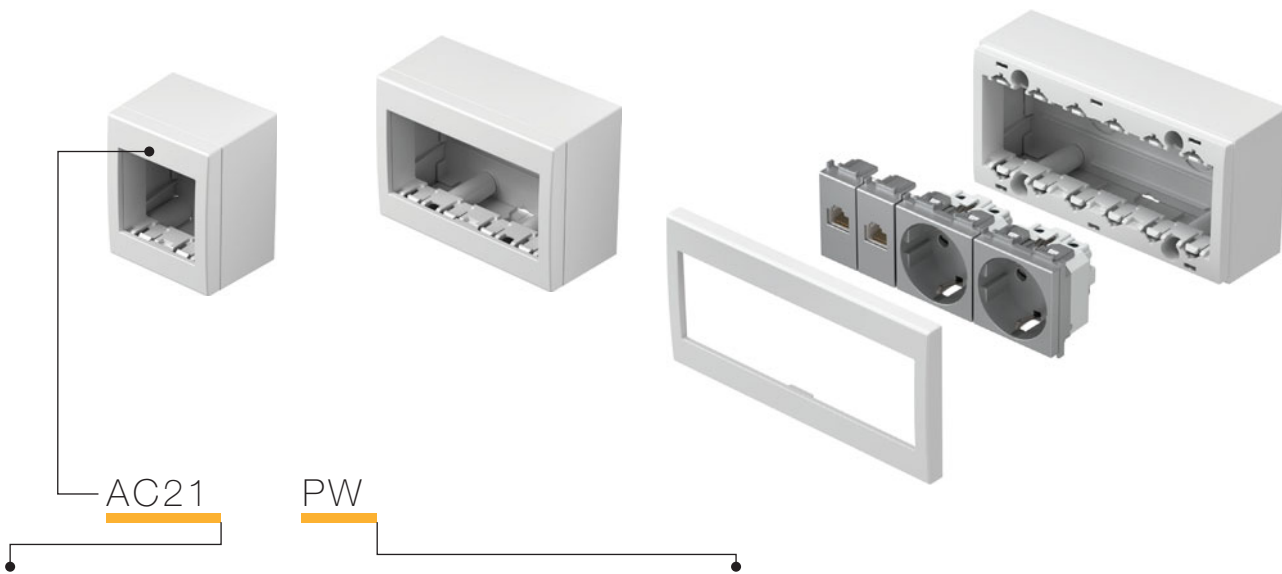

tip type	naziv description	tehnični opis technical data	velikost size	barva colour
AC11	OHIŠJE NO CUBO Z DNOM SURFACE MOUNT BOX WITH BACK SIDE COVER	IP20	1M	<input type="checkbox"/> PW bela-sijaj polar white
AC21	OHIŠJE NO CUBO Z DNOM SURFACE MOUNT BOX WITH BACK SIDE COVER	IP20	2M	<input type="checkbox"/> ES srebrna-mat elox silver
AC41	OHIŠJE NO CUBO Z DNOM SURFACE MOUNT BOX WITH BACK SIDE COVER	IP20	4M	<input type="checkbox"/> IW bež-sijaj ivory white
.

distribucija

OHIŠJE NO CUBO Z DNOM IP20 1M



- AC11PW
- AC11ES
- AC11IW

- ohišje IP20 1M
- za nadometno pritrditev elementov
- primeren za stikala SM
- ustreza EN 60669-1

BOX NO CUBO WITH BACK SIDE COVER IP20 1M

- box IP20 1M
- for surface mounting of elements
- suitable to SM switches
- in accordance with EN 60669-1

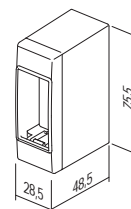

OHIŠJE NO CUBO Z DNOM IP20 2M



- AC21PW
- AC21ES
- AC21IW

- ohišje IP20 2M
- za nadometno pritrditev elementov
- ustreza EN 60669-1, EN60884-1

BOX NO CUBO WITH BACK SIDE COVER IP20 2M

- box IP20 2M
- for surface mounting of elements
- in accordance with EN 60669-1, EN60884-1

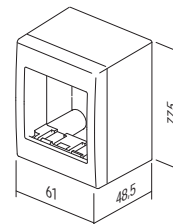

OHIŠJE NO CUBO Z DNOM IP20 4M



- AC41PW
- AC41ES
- AC41IW

- ohišje IP20 4M
- za nadometno pritrditev elementov
- ustreza EN 60669-1, EN60884-1

BOX NO CUBO WITH BACK SIDE COVER IP20 4M

- box IP20 4M
- for surface mounting of elements
- in accordance with EN 60669-1, EN60884-1

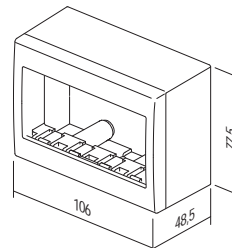

OHIŠJE NO CUBO Z DNOM IP20 6M



- AC61PW
- AC61ES
- AC61IW

- ohišje IP20 6M
- za nadometno pritrditev elementov
- ustreza EN 60669-1, EN60884-1

BOX NO CUBO WITH BACK SIDE COVER IP20 6M

- box IP20 6M
- for surface mounting of elements
- in accordance with EN 60669-1, EN60884-1

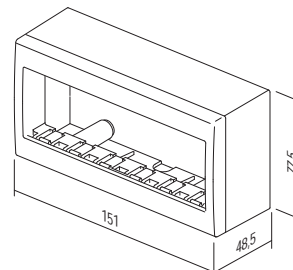

B O X E S C U B O I P 5 5 A Q



tip type	naziv description	tehnični opis technical data	velikost size	barva colour
AQ20	OHIŠJE NO CUBO OUTDOOR SURFACE MOUNT BOX	IP55	2M	<input type="checkbox"/> PW bela sijaj polar white
AQ22	OHIŠJE NO CUBO OUTDOOR SURFACE MOUNT BOX	IP55	2x2M	<input type="checkbox"/> GY siva grey
AQ30	OHIŠJE NO CUBO OUTDOOR SURFACE MOUNT BOX	IP55	3M	
AQ31	OHIŠJE PO CUBO OUTDOOR FLUSH MOUNT BOX	IP55	3M	

OHIŠJE NO CUBO IP55 2M



- AQ20PW
 AQ20GY

- ohišje IP55 2M
- za nadometno pritrditev
- IP55 za vgradnjo v vlažne prostore
- ustreza CEI 23-48, EN 60670

BOX NO CUBO IP55 2M

- box IP55 2M
- for surface mounting
- IP55 for usage in humid areas
- in accordance with CEI 23-48, EN 60670

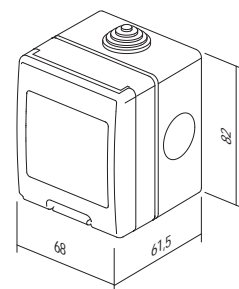

OHIŠJE NO CUBO IP55 2x2M



- AQ22PW
 AQ22GY

- ohišje IP55 2x2M
- za nadometno pritrditev
- IP55 za vgradnjo v vlažne prostore
- ustreza CEI 23-48, EN 60670

BOX NO CUBO IP55 2x2M

- box IP55 2x2M
- for surface mounting
- IP55 for usage in humid areas
- in accordance with CEI 23-48, EN 60670

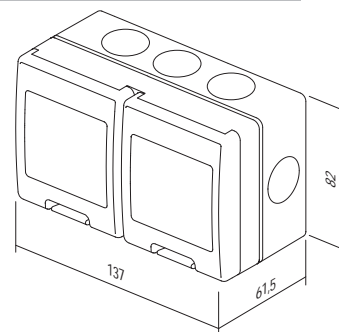

OHIŠJE NO CUBO IP55 3M



- AQ30PW
 AQ30GY

- ohišje IP55 3M
- za nadometno pritrditev
- IP55 za vgradnjo v vlažne prostore
- ustreza CEI 23-48, EN 60670

BOX NO CUBO IP55 3M

- box IP55 3M
- for surface mounting
- IP55 for usage in humid areas
- in accordance with CEI 23-48, EN 60670

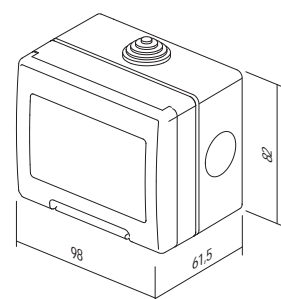

OHIŠJE PO CUBO IP55 3M



- AQ31PW
 AQ31GY

- ohišje IP55 3M
- za podometno pritrditev
- IP55 za vgradnjo v vlažne prostore
- ustreza CEI 23-48, EN 60670

BOX PO CUBO IP55 3M

- box IP55 3M
- for flush mounting
- IP55 for usage in humid areas
- in accordance with CEI 23-48, EN 60670

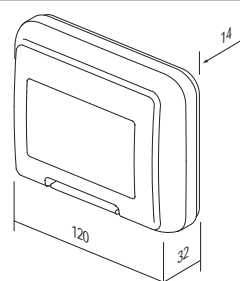

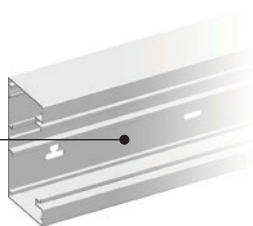
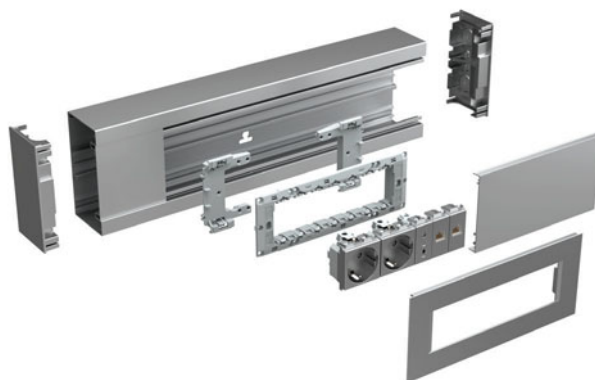

RT20

ES

distribucija

tip type	naziv description	velikost size	barva colour
RT10	ADAPTER MA 92 ADAPTER MA 92	/	■ ES srebrna-mat elox silver-mat
RT12	OKVIR MA 92 COVER PLATE MA 92	2/3M	□ PW bela-mat (RAL 9016) white-mat
RT14	OKVIR MA 92 COVER PLATE MA 92	4M	

ADAPTER MA 92



RT10

- adapter za pritrditev nosilcev 2/3M, 4M ali 7M Modul na kanal MA brez doze
- vsak nosilec potrebuje dva adapterja
- ustreza EN 50085-1

ADAPTER MA 92
- adapter for fixing mounting frames 2/3M, 4M or 7M on MA trunking without box
- each mounting frame needs two adapters
- in accordance with EN 50085-1

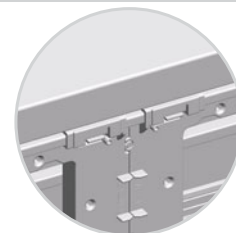

OKVIR MA 92 2/3M



■ RT12ES
□ RT12PW

- dekorativni okvir MA 2/3M
- ustreza EN 50085-1

COVER PLATE MA 92 2/3M
- decorative cover plate MA 2/3M
- in accordance with EN 50085-1

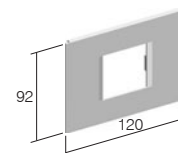

OKVIR MA 92 4M



■ RT14ES
□ RT14PW

- dekorativni okvir MA 4M
- ustreza EN 50085-1

COVER PLATE MA 92 4M
- decorative cover plate MA 4M
- in accordance with EN 50085-1

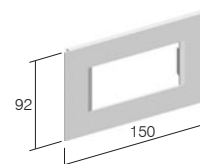

OKVIR MA 92 7M

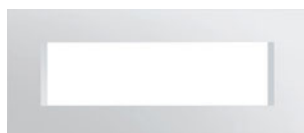

■ RT17ES
□ RT17PW

- dekorativni okvir MA 7M
- ustreza EN 50085-1

COVER PLATE MA 92 7M
- decorative cover plate MA 7M
- in accordance with EN 50085-1

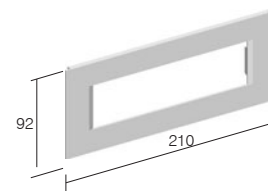

OSNOVA KANALA MA 130x65

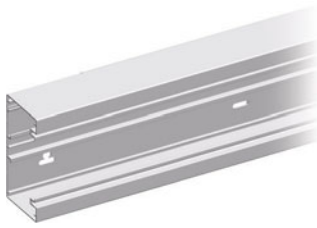

- RT20ES
- RT20PW

- osnova kanala iz ekstrudiranega aluminija
- višina 130mm, dolžina 2m
- DIN letev 35mm na dnu
- ustreza EN 50085-1

TRUNKING BASE MA 130x65
 - trunking base from extruded aluminium
 - height 130mm, length 2m
 - DIN - rail 35mm shape on bottom
 - in accordance with EN 50085-1

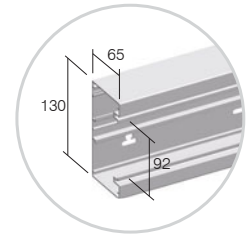

OSNOVA KANALA MA 165x65



- RT21ES
- RT21PW

- osnova kanala iz ekstrudiranega aluminija
- višina 165mm, dolžina 2m
- DIN letev 35mm na dnu
- ustreza EN 50085-1

TRUNKING BASE MA 165x65
 - trunking base from extruded aluminium
 - height 165mm, length 2m
 - DIN - rail 35mm shape on bottom
 - in accordance with EN 50085-1

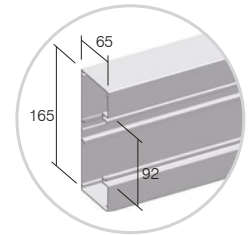

POKROV KANALA MA 92



- RT25ES
- RT25PW

- pokrov kanala iz ekstrudiranega aluminija
- višina 92mm, dolžina 2m
- ustreza EN 50085-1

FRONT COVER MA 92
 - front cover from extruded aluminium
 - height 92mm, length 2m
 - in accordance with EN 50085-1

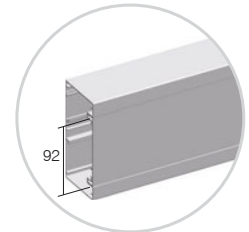

PREGRADA MA 43



RT30

- pregrada kanala iz ekstrudiranega polimera
- globina 43mm, dolžina 2m
- ustreza EN 50085-1

CABLE SHELF MA 43
 - cable shelf from extruded polymer
 - depth 43mm, length 2m
 - in accordance with EN 50085-1

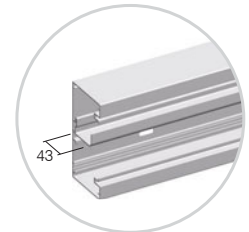

PREGRADA MA 43 AL



RT31

- pregrada kanala iz ekstrudiranega aluminija
- globina 43mm, dolžina 2m
- ustreza EN 50085-1

CABLE SHELF MA 43 AL
 - cable shelf from extruded aluminium
 - depth 43mm, length 2m
 - in accordance with EN 50085-1

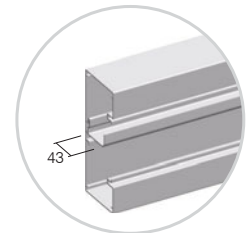

PREGRADA MA 43 AL DVOJNA



RT32

- dvojna pregrada kanala iz ekstrudiranega aluminija
- globina 43mm, dolžina 2m
- ustreza EN 50085-1

CABLE SHELF MA 43 AL DOUBLE
 - double cable shelf from extruded aluminium
 - depth 43mm, length 2m
 - in accordance with EN 50085-1

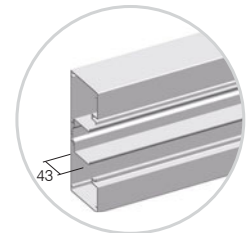

KONČNI ELEMENT MA 130x65



RT35ES
 RT35PW

- končni element iz polimera
 - višina 130mm
 - ustreza EN 50085-1

STOP END MA 130x65
 - stop end element from polymer
 - height 130mm
 - in accordance with EN 50085-1

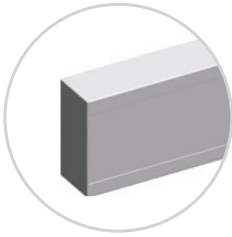

KONČNI ELEMENT MA 165x65



RT36ES
 RT36PW

- končni element iz kovine
 - višina 165mm
 - ustreza EN 50085-1

STOP END MA 165x65
 - stop end element from metal
 - height 165mm
 - in accordance with EN 50085-1



SET RAVNI VEZNI ELEMENT MA 65



RT38

- vezni element iz polimera
 - set vsebuje 2 vezna elementa in vijake
 - ustreza EN 50085-1

SET JOINING PIECE MA 65
 - joining piece from polymer
 - set contains two pieces and screws
 - in accordance with EN 50085-1



UNIVERZALNI KOT MA 130x65



RT40ES
 RT40PW

- univerzalni kotni element
 - višina 130mm
 - ustreza EN 50085-1

UNIVERSAL CORNER MA 130x65
 - universal corner element
 - height 130mm
 - in accordance with EN 50085-1



UNIVERZALNI KOT MA 165x65



RT41ES
 RT41PW

- univerzalni kotni element
 - višina 165mm
 - ustreza EN 50085-1

UNIVERSAL CORNER MA 165x65
 - universal corner element
 - height 165mm
 - in accordance with EN 50085-1



OZEMLJITVENA SPONKA MA 2x A6.3



RT42

- ozemljitvena sponka za ozemljitev osnove
 in pokrova kanala
 - ustreza EN 50085-1

EARTHING PIECE MA 2x A6.3
 - earthing piece for earthing of trunking base
 and front cover
 - in accordance with EN 50085-1

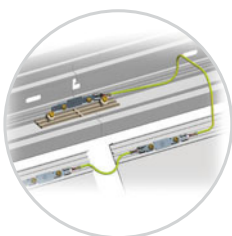

L KOTNI ELEMENT MA 130x65

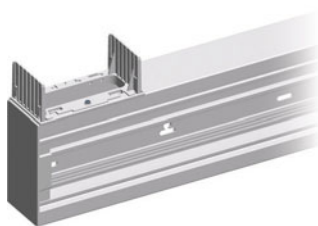

- RT43ES
- RT43PW

- univerzalni L kotni element iz aluminija
- višina 130mm, dolžina 400mm
- ustreza EN 50085-1

L-BEND MA 130x65

- universal L bend element from aluminium
- height 130mm, length 400mm
- in accordance with EN 50085-1

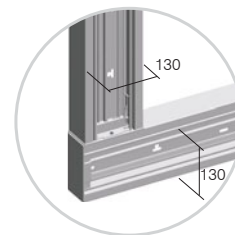

L KOTNI ELEMENT MA 165x65

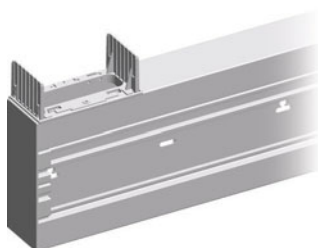

- RT44ES
- RT44PW

- univerzalni L kotni element iz aluminija
- višina 165mm, dolžina 400mm
- vezava na MA 130x65
- ustreza EN 50085-1

L-BEND MA 165x65

- universal L bend element from aluminium
- height 165mm, length 400mm
- connection on MA 130x65
- in accordance with EN 50085-1

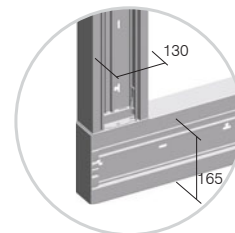

T ELEMENT MA 130x65

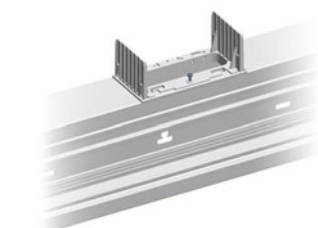

- RT45ES
- RT45PW

- univerzalni T kotni element iz aluminija
- višina 130mm, dolžina 400mm
- ustreza EN 50085-1

T-BEND MA 130x65

- universal T bend element from aluminium
- height 130mm, length 400mm
- in accordance with EN 50085-1

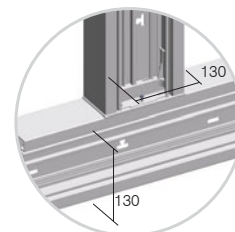

T ELEMENT MA 165x65

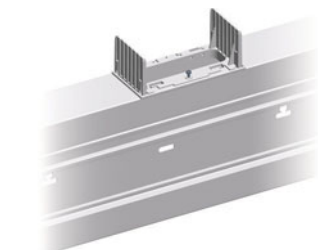

- RT46ES
- RT46PW

- univerzalni T kotni element iz aluminija
- višina 165mm, dolžina 400mm
- vezava na MA 130x65
- ustreza EN 50085-1

T-BEND MA 165x65

- universal T bend element from aluminium
- height 165mm, length 400mm
- connection on MA 130x65
- in accordance with EN 50085-1

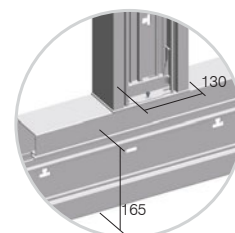

MA je modularni sistem za velikosti: 2M, 4M, 7M

MA trunking is based on modular system making 2M, 4M or 7M combinations of elements

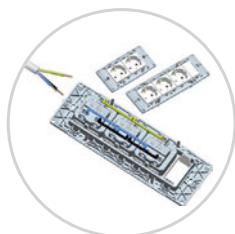

Modul vsebuje tudi elemente pripravljene za hitro montažo

In Modul we provide special elements for quick installation

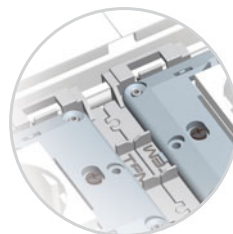

Adapter MA omogoča natančno pozicioniranje na rob kanala

With Adapter MA exact positioning without extra effort is provided

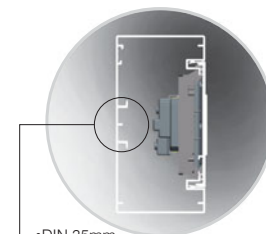

Montaža brez doze pomeni več prostora za kable, DIN letev oblika EN-60715

Mounted without box means more space for cables, DIN-rail base shape EN-60715

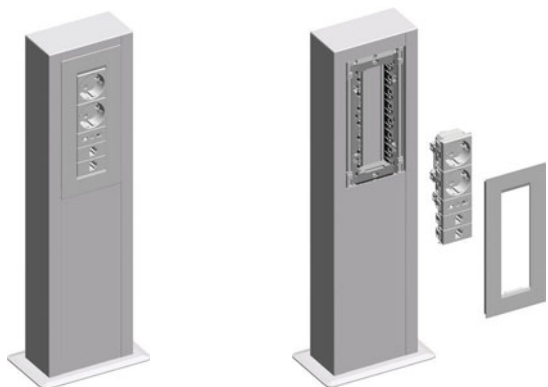

NOSILEC STEBRIČKA MA ENOJNI 130x65

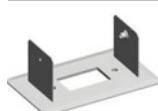

- RT50ES
- RT50PW

- nosilec za pritržitev kanala MA130 v tla in/ali v strop prostora
- ustreza EN 50085-1

FIXING PLATE MA SINGLE 130x65

- fixing plate for fixing trunking base MA130 on the floor
and/or on the ceiling
- in accordance with EN 50085-1

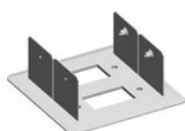
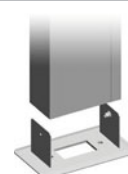

- RT51ES
- RT51PW

NOSILEC STEBRIČKA MA DVOJNI 130x65

- nosilec za pritržitev dveh kanalov MA130 v tla
in/ali v strop prostora
- ustreza EN 50085-1

FIXING PLATE MA DOUBLE 130x65

- fixing plate for fixing two trunking bases MA130 on the floor
and/or on the ceiling
- in accordance with EN 50085-1

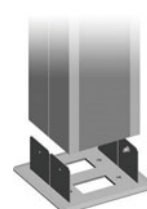

STEBRIČEK MA 130x65x500

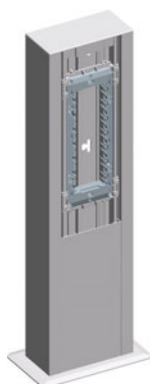

- RT52ES
- RT52PW

- instalacijski stebriček MA
- višina 500mm
- nosilec 7M vgrajen
- ustreza EN 50085-1

SERVICE POST MA 130x65x500

- service post MA
- height 500mm
- mounting frame 7M included
- in accordance with EN 50085-1

STEBRIČEK MA DVOJNI 130x130x500

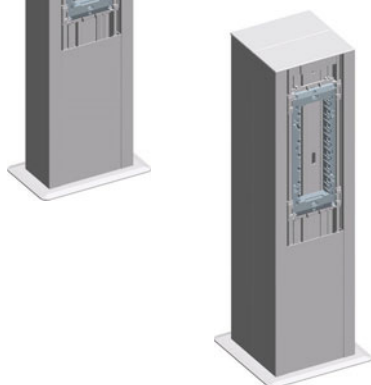

- RT53ES
- RT53PW

- instalacijski stebriček MA dvojni
- višina 500mm
- nosilca 7M vgrajena
- ustreza EN 50085-1

SERVICE POST MA DOUBLE 130x130x500

- service post MA double
- height 500mm
- mounting frames 7M included
- in accordance with EN 50085-1

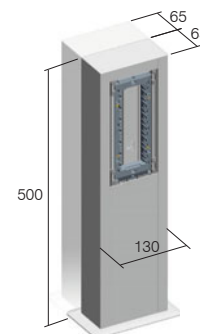

Presek vodnika/ Cable intersection mm ²	Uporabni presek kablov / Cable cross-section (mm ²)				
	1 vodnik/ 1 wire	2 vodnika/ 2 wires	3 vodniki/ 3 wires	4 vodniki/ 4 wires	5 vodnikov/ 5 wires
1,5	44	111	121	144	169
2,5	49	133	157	169	211
4	58	169	183	211	256
6	68	196	225	256	307

Kapaciteta kanala / Trunk capacity				
kanal/ Trunk	MA 130x65 prazen/ empty	MA 130x65 z Modul opremo/ with Modul switches and sockets	MA 165x65 prazen/ empty	MA 165x65 z Modul opremo/ with Modul switches and sockets
kapaciteta/capacity	7600 mm ²	5500 mm ²	9900 mm ²	7800 mm ²
max ø	54 mm	2x42 mm	54 mm	2x42 mm

F L O O R B O X E S M T

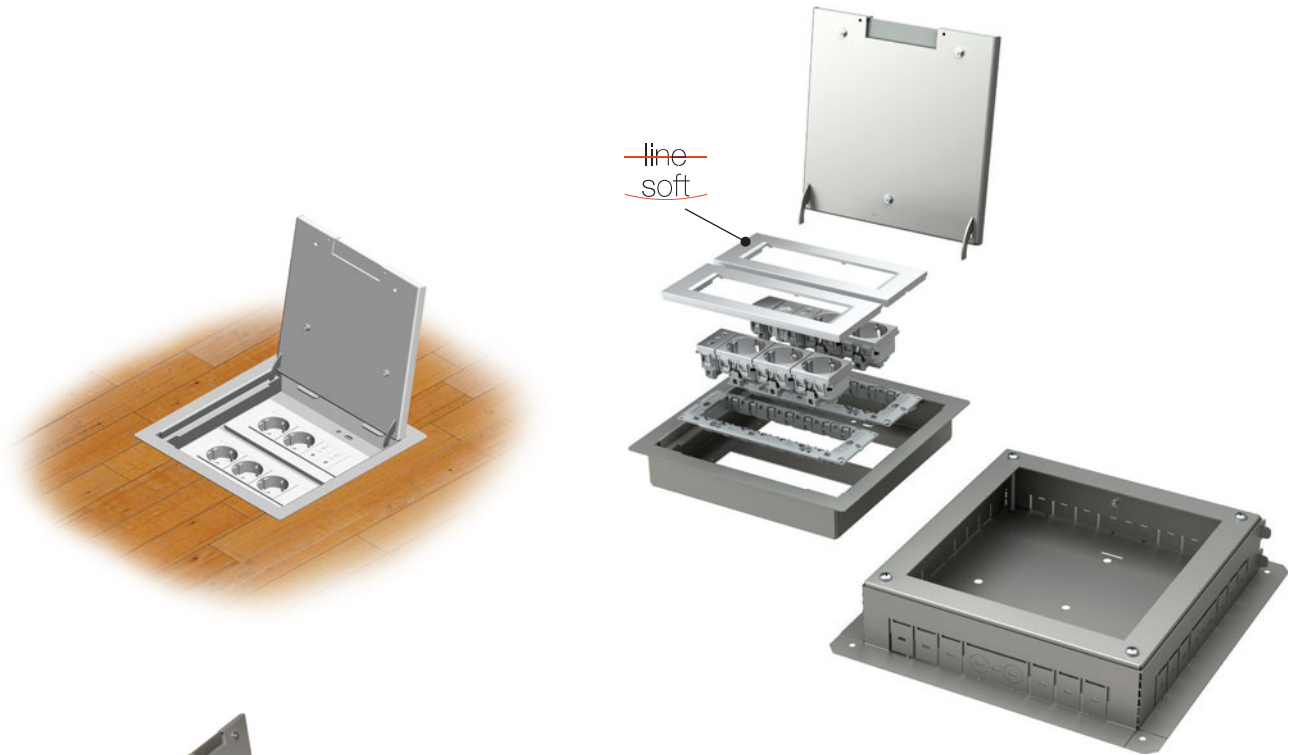

RB33

tip type	naziv description	tehnični opis technical data
RB30	TALNA DOZA FLOOR BOX	MT 7
RB31	PODSTAVEK TALNE DOZE FLOOR BOX FLANGE	MT 7
RB33	TALNA DOZA FLOOR BOX	MT 14
.	.	.
.	.	.

	RB30	RB33	RB36	RB40	RB43	RB46
a	170	260	350	170	260	350
b	260	260	260	260	260	260
X	140	230	320	140	230	320
Y	230	230	230	230	230	230

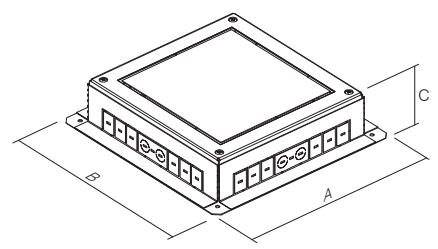
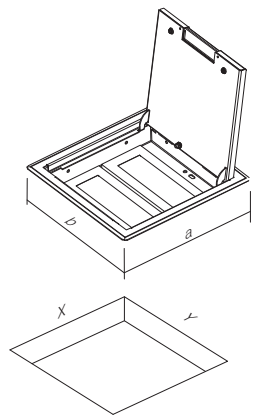

	RB31	RB34	RB37	RB41	RB44	RB47
A	270	360	450	270	360	450
B	360	360	360	360	360	360
C	95-125	95-125	95-125	120-150	120-150	120-150

TALNA DOZA MT 7



RB30

- talna doza MT 7
- kovinska, barva srebrna RAL 9006
- nosilec MODUL 7M vgrajen
- vgradna mera 140x230mm, globina min 95mm
- debelina talne obloge pokrova do 10mm
- ustreza EN 50085-1 in EN 50085-2-2

FLOOR BOX MT 7

- floor box MT 7
- metal, colour silver RAL 9006
- mounting frame MODUL 7M included
- mounting dimensions 140x230mm, depth min 95mm
- floor lining thickness up to 10mm
- in accordance with EN 50085-1 and EN 50085-2-2

TALNA DOZA MT 7 H=88mm



RB40

- talna doza MT 7
- kovinska, barva srebrna RAL 9006
- nosilec MODUL 7M vgrajen
- vgradna mera 140x230mm, globina min 120mm
- debelina talne obloge pokrova do 10mm
- ustreza EN 50085-1 in EN 50085-2-2

FLOOR BOX MT 7 H=88mm

- floor box MT 7
- metal, colour silver RAL 9006
- mounting frame MODUL 7M included
- mounting dimensions 140x230mm, depth min 120mm
- floor lining thickness up to 10mm
- in accordance with EN 50085-1 and EN 50085-2-2

PODSTAVEK TALNE DOZE MT 7



RB31

- podstavek talne doze za pokrov MT 7
- kovinski, cinkan
- za vgradnjo v tlak ali dvojni pod
- nastavljiva višina 95-125mm
- ustreza EN 50085-1 in EN 50085-2-2

FLOOR BOX FLANGE MT 7

- floor box flange for box cover MT 7
- metal, galvanized
- for installation in a floor or double floor
- adjustable height 95-125mm
- in accordance with EN 50085-1 and EN 50085-2-2

PODSTAVEK TALNE DOZE MT 7 H=88mm



RB41

- podstavek talne doze za pokrov MT 7 H=88mm
- kovinski, cinkan
- za vgradnjo v tlak ali dvojni pod
- nastavljiva višina 120-150mm
- ustreza EN 50085-1 in EN 50085-2-2

FLOOR BOX FLANGE MT 7 H=88mm

- floor box flange for box cover MT 7 H=88mm
- metal, galvanized
- for installation in a floor or double floor
- adjustable height 120-150mm
- in accordance with EN 50085-1 and EN 50085-2-2

TALNA DOZA MT 14



RB33

- talna doza MT 14
- kovinska, barva srebrna RAL 9006
- nosilca MODUL 2x7M vgrajena
- vgradna mera 230x230mm, globina min 95mm
- debelina talne obloge pokrova do 10mm
- ustreza EN 50085-1 in EN 50085-2-2

FLOOR BOX MT 14

- floor box MT 14
- metal, colour silver RAL 9006
- mounting frames MODUL 2x7M included
- mounting dimensions 230x230mm, depth min 95mm
- floor lining thickness up to 10mm
- in accordance with EN 50085-1 and EN 50085-2-2

TALNA DOZA MT 14 H=88mm



RB43

- talna doza MT 14
- kovinska, barva srebrna RAL 9006
- nosilca MODUL 2x7M vgrajena
- vgradna mera 230x230mm, globina min 120mm
- debelina talne obloge pokrova do 10mm
- ustreza EN 50085-1 in EN 50085-2-2

FLOOR BOX MT 14 H=88mm

- floor box MT 14
- metal, colour silver RAL 9006
- mounting frames MODUL 2x7M included
- mounting dimensions 230x230mm, depth min 120mm
- floor lining thickness up to 10mm
- in accordance with EN 50085-1 and EN 50085-2-2

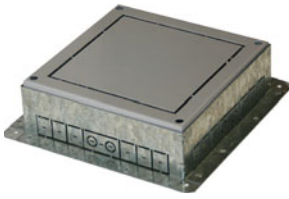
PODSTAVEK TALNE DOZE MT 14

RB34

- podstavek talne doze za pokrov MT 14
- kovinski, cinkan
- za vgradnjo v tlak ali dvojni pod
- nastavljiva višina 95-125mm
- ustreza EN 50085-1 in EN 50085-2-2

FLOOR BOX FLANGE MT 14

- floor box flange for box cover MT 14
- metal, galvanized
- for installation in a floor or double floor
- adjustable height 95-125mm
- in accordance with EN 50085-1 and EN 50085-2-2

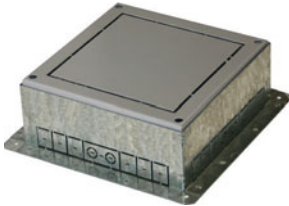
PODSTAVEK TALNE DOZE MT 14 H=88mm

RB44

- podstavek talne doze za pokrov MT 14 H=88mm
- kovinski, cinkan
- za vgradnjo v tlak ali dvojni pod
- nastavljiva višina 120-150mm
- ustreza EN 50085-1 in EN 50085-2-2

FLOOR BOX FLANGE MT 14 H=88mm

- floor box flange for box cover MT 14 H=88mm
- metal, galvanized
- for installation in a floor or double floor
- adjustable height 120-150mm
- in accordance with EN 50085-1 and EN 50085-2-2

TALNA DOZA MT 21

RB36

- talna doza MT 21
- kovinska, barva srebrna RAL 9006
- nosilci MODUL 3x7M vgrajeni
- vgradna mera 320x230mm, globina min 95mm
- debelina talne obloge pokrova do 10mm
- ustreza EN 50085-1 in EN 50085-2-2

FLOOR BOX MT 21

- floor box MT 21
- metal, colour silver RAL 9006
- mounting frames MODUL 3x7M included
- mounting dimensions 320x230mm, depth min 95mm
- floor lining thickness up to 10mm
- in accordance with EN 50085-1 and EN 50085-2-2

TALNA DOZA MT 21 H=88mm

RB46

- talna doza MT 21
- kovinska, barva srebrna RAL 9006
- nosilci MODUL 3x7M vgrajeni
- vgradna mera 320x230mm, globina min 120mm
- debelina talne obloge pokrova do 10mm
- ustreza EN 50085-1 in EN 50085-2-2

FLOOR BOX MT 21 H=88mm

- floor box MT 21
- metal, colour silver RAL 9006
- mounting frames MODUL 3x7M included
- mounting dimensions 320x230mm, depth min 120mm
- floor lining thickness up to 10mm
- in accordance with EN 50085-1 and EN 50085-2-2

PODSTAVEK TALNE DOZE MT 21

RB37

- podstavek talne doze za pokrov MT 21
- kovinski, cinkan
- za vgradnjo v tlak ali dvojni pod
- nastavljiva višina 95-125mm
- ustreza EN 50085-1 in EN 50085-2-2

FLOOR BOX FLANGE MT 21

- floor box flange for box cover MT 21
- metal, galvanized
- for installation in a floor or double floor
- adjustable height 95-125mm
- in accordance with EN 50085-1 and EN 50085-2-2

PODSTAVEK TALNE DOZE MT 21 H=88mm

RB47

- podstavek talne doze za pokrov MT 21 H=88mm
- kovinski, cinkan
- za vgradnjo v tlak ali dvojni pod
- nastavljiva višina 120-150mm
- ustreza EN 50085-1 in EN 50085-2-2

FLOOR BOX FLANGE MT 21 H=88mm

- floor box flange for box cover MT 21 H=88mm
- metal, galvanized
- for installation in a floor or double floor
- adjustable height 120-150mm
- in accordance with EN 50085-1 and EN 50085-2-2

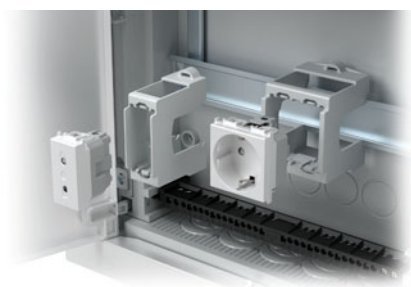

RB20

distribucija

tip type	naziv description	tehnični opis technical data
RB10	ADAPTER ZA DIN LETEV ADAPTER FOR DIN RAIL	35mm 1M
RB11	ADAPTER ZA DIN LETEV ADAPTER FOR DIN RAIL	35mm 2M
RB20	RAZVODNA OMARICA DISTRIBUTION BOX	MO 12+2
.	.	.
.	.	.

ADAPTER ZA DIN LETEV 35mm 1M



RB10

- adapter MODUL 1M
- za DIN letev 35mm
- ustreza EN 50022

ADAPTER FOR DIN RAIL 35mm 1M
- adapter MODUL 1M
- for DIN rail 35mm
- in accordance with EN 50022

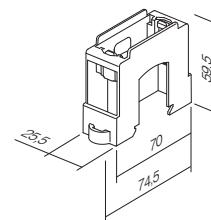

ADAPTER ZA DIN LETEV 35mm 2M



RB11

- adapter MODUL 2M
- za DIN letev 35mm
- ustreza EN 50022

ADAPTER FOR DIN RAIL 35mm 2M
- adapter MODUL 2M
- for DIN rail 35mm
- in accordance with EN 50022

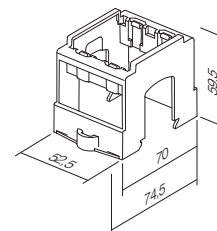

RAZVODNA OMARICA MO 12+2



RB20

- razvodna omarica MO enoredna 12+2MU
- 400V~, razred zaščite II, IP40
- kovinska vratca in okvir, barva bela RAL 9016
- ozemljitvene in ničelne sponke priložene
- univerzalna vgradnja v zid ali votlo steno
- ustreza EN 60670-1 in IEC 60670-24

DISTRIBUTION BOX MO 12+2

- *distribution box MO single row 12+2MU*
- *400V~, Class II, IP40*
- *metal leveling frame and door, colour white RAL 9016*
- *neutral and earth conductor terminals enclosed*
- *universal for brick or hollow wall mounting*
- *in accordance with EN 60670-1 and IEC 60670-24*

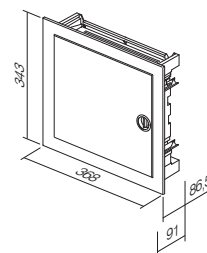

RAZVODNA OMARICA MO 24+4



RB21

- razvodna omarica MO dvoredna 24+4MU
- 400V~, razred zaščite II, IP40
- kovinska vratca in okvir, barva bela RAL 9016
- ozemljitvene in ničelne sponke priložene
- univerzalna vgradnja v zid ali votlo steno
- ustreza EN 60670-1 in IEC 60670-24

DISTRIBUTION BOX MO 24+4

- *distribution box MO double row 24+4MU*
- *400V~, Class II, IP40*
- *metal leveling frame and door, colour white RAL 9016*
- *neutral and earth conductor terminals enclosed*
- *universal for brick or hollow wall mounting*
- *in accordance with EN 60670-1 and IEC 60670-24*

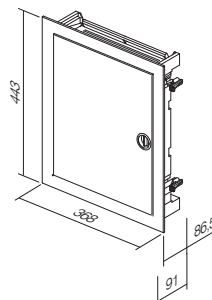

RAZVODNA OMARICA MO 36+6



RB22

- razvodna omarica MO triredna 36+6MU
- 400V~, razred zaščite II, IP40
- kovinska vratca in okvir, barva bela RAL 9016
- ozemljitvene in ničelne sponke priložene
- univerzalna vgradnja v zid ali votlo steno
- ustreza EN 60670-1 in IEC 60670-24

DISTRIBUTION BOX MO 36+6

- *distribution box MO triple row 36+6 MU*
- *400V~, Class II, IP40*
- *metal leveling frame and door, colour white RAL 9016*
- *neutral and earth conductor terminals enclosed*
- *universal for brick or hollow wall mounting*
- *in accordance with EN 60670-1 and IEC 60670-24*

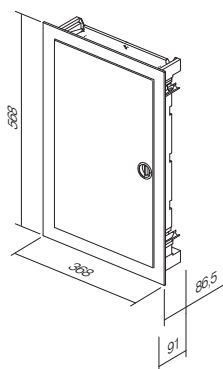

RAZVODNA OMARICA MO 48+8



RB23

- razvodna omarica MO štiriredna 48+8MU
- 400V~, razred zaščite II, IP40
- kovinska vratca in okvir, barva bela RAL 9016
- ozemljitvene in ničelne sponke priložene
- univerzalna vgradnja v zid ali votlo steno
- ustreza EN 60670-1 in IEC 60670-24

DISTRIBUTION BOX MO 48+8

- *distribution box MO quad row 48+8 MU*
- *400V~, Class II, IP40*
- *metal leveling frame and door, colour white RAL 9016*
- *neutral and earth conductor terminals enclosed*
- *universal for brick or hollow wall mounting*
- *in accordance with EN 60670-1 and IEC 60670-24*

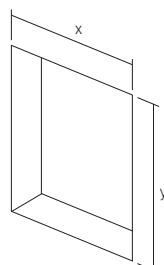
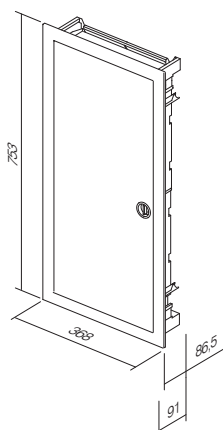

	RB20	RB21	RB22	RB23
x	314	314	314	314
y	314	414	539	724



ekonomik[®]



Planned for excellence
Style is essential



ERGO

METAL

SOFT

Nevtralen, kompakten, eleganten dizajn se prilagodi v vsako okolje v katerem bivate ali delate. V interierju ne izstopa temveč z njim harmonično zaživi.

A neutral, compact, elegant design is adjustable to every working or living area. It does not stick out from the interior, but rather harmonically fits into it.

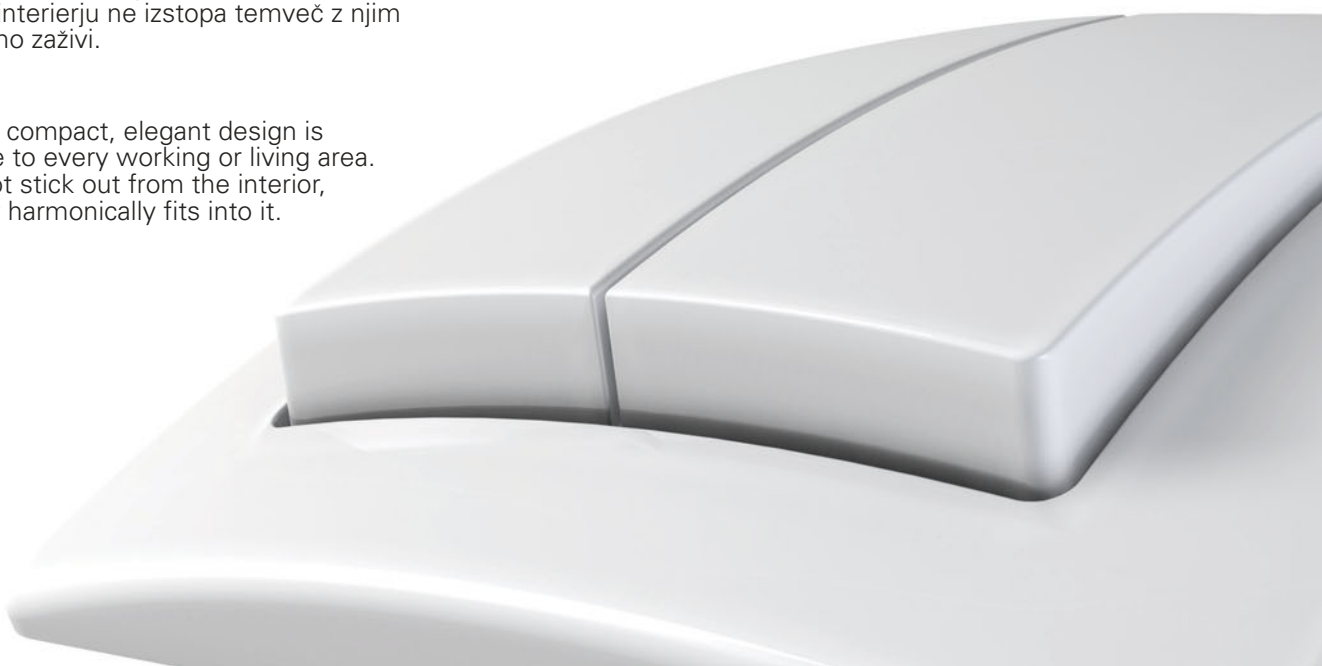



Načrtovano za odličnost Bistven je slog



Čista linija ekonomik je nežno zaobljena premišljena ergonomija posebej za vas.

A pure line is slightly curved - well considered ergonomics especially for you.



Izirate lahko med sijajno refleksnimi površinami in sodobnim kovinskim izgledom.

You can choose between shiny reflective surfaces and modern metallic look.



Mehkost oblike bo našla prostor v modernih in klasičnih interierjih.

The softness of the form will find its place in modern as well as in classic interiors.

HARMONY

REFLEX

UV PROTECT

Želje so različne. Zato smo za vas pozorno izbrali možnosti, ki vam nudijo pravi odgovor. Nevtralna paleta barv bo le dopolnila vaš ambient - ne bo vas omejeval.

Desires can be very different. Therefore we have carefully selected possibilities for you, which can offer you the right answer. A neutral palette of colours will only complement your ambient - it will not restrict it.

Press and the world will spring to life
Colourful landscape between walls



Refleksne občutke vam nudijo sijajni polimerni materiali v beli in biserno beli (beige) barvi.

Shiny polymer materials in white and beige colours enable reflective mood.



Moderen in nevtralen je tudi izbrani dekorativni kovinski nanos.

Selected decorative metallic coat is at the same time modern and neutral.

Pritisnite in svet bo zaživel

Barvita pokrajina med stenami



Za vse vas, ki se želite igrati s pastelnimi barvami je rešitev Ekonomik Color.

For those who want to play with pastel colours Ekonomik Color represents a perfect solution.



Robustnost in visoka odpornost na zunanje vplive (UV) je zagotovljena z duroplastičnim materialom (Color).

Robustness and high resistance to external effects (UV) are secured by duroplastic materials (Color line).

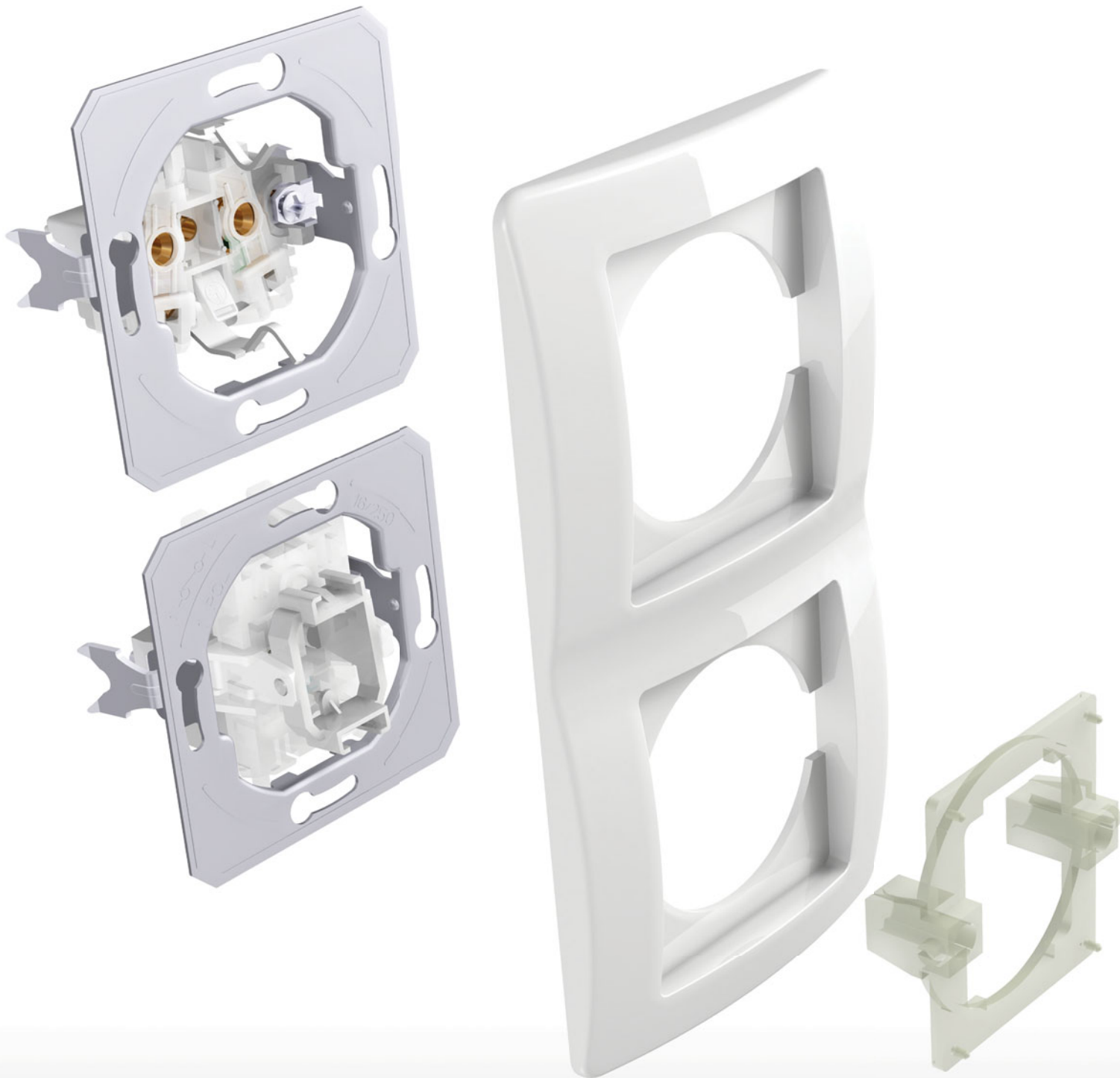

VERTICAL

HORIZONTAL

SAVE SPACE



S sestavljanjem prihranite prostor na steni. Ko imate malo prostora, je navpično prava odločitev.

With combining you save space on the wall. When faced with a limited space, "vertically" is the right decision.



Kombinirajte kot sami želite.

Combine as you please.



Vidni elementi se enostavno demontirajo. Hvaležni vam bodo tudi pleskarski mojstri.

Visible elements can be easily taken apart. Painters will be grateful to you.



Prolonge your day with a touch
Simplified living

Z dotikom si podaljšamo dan Poenostavljeno bivanje

Ekonomik je rešitev za sistem standardnih okroglih doz. Z njim lahko načrtujete tako enostavne kot tudi zahtevnejše inštalacije, novogradnje in adaptacije. Sistem odlikujejo brezvijačni kontakti, ki vam prihranijo čas pri vgradnji elementov.

Ekonomik is a solution for the system of standardized round installations boxes. It can be used for simple as well as more demanding installations, new buildings and adaptations. The system is characterised by plug-in contacts which save time during installation of elements.

Dobro počutje v varnem zavetju Popolno zaupanje v dobro konstrukcijo

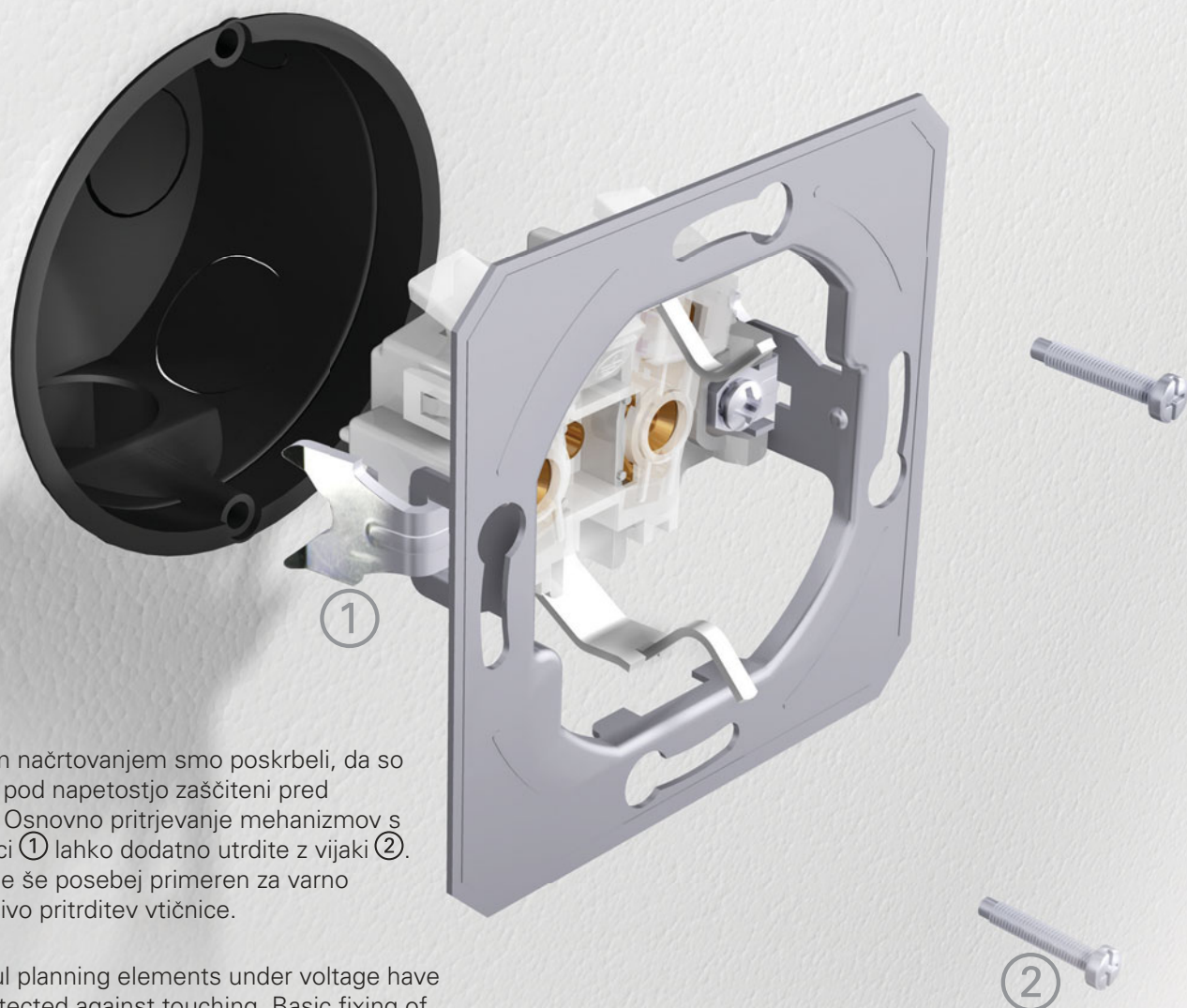

S skrbnim načrtovanjem smo poskrbeli, da so elementi pod napetostjo zaščiteni pred dotikom. Osnovno pritrjevanje mehanizmov s krepeljci ① lahko dodatno utrdite z vijaki ②. Ta način je še posebej primeren za varno in zanesljivo pritrnitev vtičnice.

By careful planning elements under voltage have been protected against touching. Basic fixing of mechanisms with fixing claws ① allows additional strengthening with screws ②. This manner is especially appropriate for safe and reliable fixing of sockets.

SIMPLE

FAST

FLEX

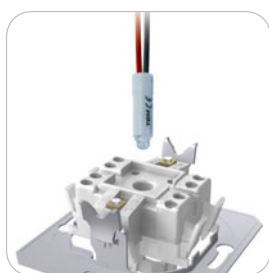

Dobro premišljena konstrukcija stikala omogoča enostavno osvetlitev tudi naknadno.

A well-planned switch construction makes easy illumination possible also subsequently.



Brezvijačni kontakti omogočajo hitro in zanesljivo priključitev vodnikov. Na isti kontakt lahko pritrдите dva vodnika različnih premerov.

Plug-in contacts enable quick and reliable attachment of wires. Two wires of different diameters can be attached to the same contact.

Sestavljive doze vam bodo olajšale delo. Prave razdalje so vam zagotovljene.

Easy-fitting installation boxes will make your work easier. Proper lengths are guaranteed.



Feeling well in a safe shelter Total confidence in a good construction

SAFE

THRUST

CERTIFIED

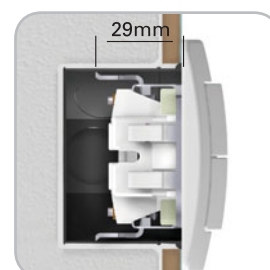

Krempeljci omogočajo globljo pritrditev (tudi preko keramičnih ploščic ipd.).

Fixing claws enable deeper fixing (also through ceramic tiles, etc.)



Vsa stikala imajo jasno identifikacijo z zadnje strani.

All switches have a clear identification in the back.

Stikala so preizkušena po mednarodnih standardnih, ki zagotavljajo varnost in dolgo življenjsko dobo.

Switches were tested according to international standards which guarantee safety and long life span.







Za zanesljivost preklopa skrbijo kontakti iz srebrne zlitine (AgNi).

Contacts made of silver alloy (Ag-Ni) guarantee safe switching.







TEM

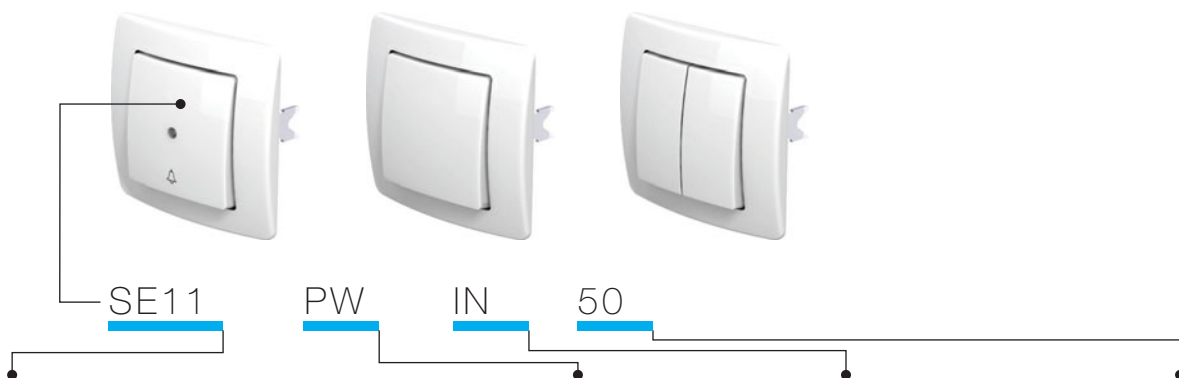



STIKALA SE <i>SWITCHES SE</i>		170
TIPKE TE <i>BUTTONS TE</i>		174
INDIKACIJA IA <i>ILLUMINATION IA</i>		175
VTIČNICE VE <i>SOCKETS VE</i>		177
KOMUNIKACIJE KE <i>COMMUNICATIONS KE</i>		181
POKROVI PE <i>COVERS PE</i>		185
ELEKTRONIKA EE <i>ELECTRONICS EE</i>		186
PRIBOR AE <i>ACCESSORIES AE</i>		191
OKVIRJI OE <i>SURROUNDS OE</i>		193



tip type	naziv description	tehnični opis technical data	barva colour	opcijski opis 1 optional data 1	opcijski opis 2 optional data 2
SE10	STIKALO ENOPOLNO SWITCH 1WAY	10AX 250V~	<input type="checkbox"/> PW bela-sijaj polar white	 NT nevtral neutral	 50
SE11	TIPKALO ENOPOLNO PUSH BUTTON 1WAY	10A 250V~	<input type="checkbox"/> IW bež-sijaj ivory white	 IN indikator indication	 51
SE22	STIKALO DVOPOLNO SWITCH 2POLE	16AX 250V~	<input type="checkbox"/> ES srebrna-mat elox silver		 03
			<input type="checkbox"/> CO beli duroplast white thermoset		 04
			<input type="checkbox"/> NB črna-sijaj night black		 04

STIKALO ENOPOLNO 10AX 250V~



SE10

- 10AX 250V~, tip SE10
 - ustreza EN 60669-1
 - brezvijačna pritrditev vodnikov 1.5-2.5mm²
- SWITCH 1WAY 16AX 250V~
- 10AX 250V~, type SE10
 - in accordance with EN 60669-1
 - plug-in contacts 1.5-2.5mm²

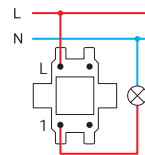

TIPKALO ENOPOLNO 10A 250V~



SE11

- 10A 250V~, tip SE11
 - ustreza EN 60669-1
 - brezvijačna pritrditev vodnikov 1.5-2.5mm²
- PUSH BUTTON 1WAY 10A 250V~
- 10A 250V~, type SE11
 - in accordance with EN 60669-1
 - plug-in contacts 1.5-2.5mm²

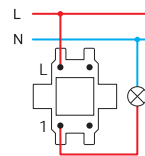

STIKALO DVOPOLNO 16AX 250V~



SE22

- 16AX 250V~, tip SE22
 - ustreza EN 60669-1
 - vijajna pritrditev vodnikov 1.5-2.5mm²
 - samo v kombinaciji s tipko TE10__NT03
- SWITCH 2POLE 16AX 250V~
- 16AX 250V~, type SE22
 - in accordance with EN 60669-1
 - screw contacts 1.5-2.5mm²
 - only in combination with button TE10__NT03

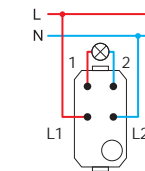
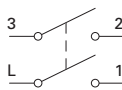

STIKALO SERIJSKO 10AX 250V~



SE50

- 10AX 250V~, tip SE50
 - ustreza EN 60669-1
 - brezvijačna pritrditev vodnikov 1.5-2.5mm²
- SWITCH 2GANG-1WAY 10AX 250V~
- 10AX 250V~, type SE50
 - in accordance with EN 60669-1
 - plug-in contacts 1.5-2.5mm²

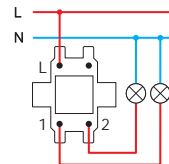
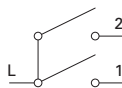

TIPKALO SERIJSKO 10A 250V~



SE51

- 10A 250V~, tip SE51
 - ustreza EN 60669-1
 - brezvijačna pritrditev vodnikov 1.5-2.5mm²
- PUSH BUTTON 2GANG-1WAY 10A 250V~**
- 10A 250V~, type SE51
 - in accordance with EN 60669-1
 - plug-in contacts 1.5-2.5mm²

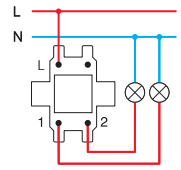
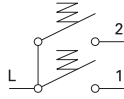

STIKALO ŽALUZIJSKO 10AX 250V~



SE52

- 10AX 250V~, tip SE52
 - ustreza EN 60669-1
 - brezvijačna pritrditev vodnikov 1.5-2.5mm²
 - z mehansko blokado hkratnega vklopa
- SWITCH SHUTTERS 10AX 250V~**
- 10AX 250V~, type SE52
 - in accordance with EN 60669-1
 - plug-in contacts 1.5-2.5mm²
 - with mechanical interblock

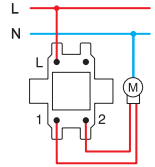
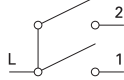

TIPKALO ŽALUZIJSKO 10A 250V~



SE53

- 10A 250V~, tip SE53
 - ustreza EN 60669-1
 - brezvijačna pritrditev vodnikov 1.5-2.5mm²
 - z mehansko blokado hkratnega vklopa
- PUSH BUTTON SHUTTERS 10A 250V~**
- 10A 250V~, type SE53
 - in accordance with EN 60669-1
 - plug-in contacts 1.5-2.5mm²
 - with mechanical interblock

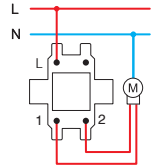
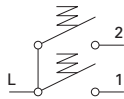

STIKALO MENJALNO 10AX 250V~



SE60

- 10AX 250V~, tip SE60
 - ustreza EN 60669-1
 - brezvijačna pritrditev vodnikov 1.5-2.5mm²
- SWITCH 2WAY 10AX 250V~**
- 10AX 250V~, type SE60
 - in accordance with EN 60669-1
 - plug-in contacts 1.5-2.5mm²

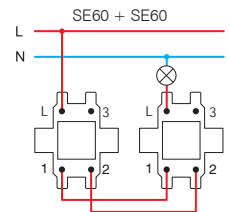
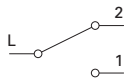

STIKALO DVOJNO MENJALNO 10AX 250V~



SE63

- 10AX 250V~, tip SE63
 - ustreza EN 60669-1
 - brezvijačna pritrditev vodnikov 1.5-2.5mm²
- SWITCH DOUBLE 2WAY 10AX 250V~**
- 10AX 250V~, type SE63
 - in accordance with EN 60669-1
 - plug-in contacts 1.5-2.5mm²

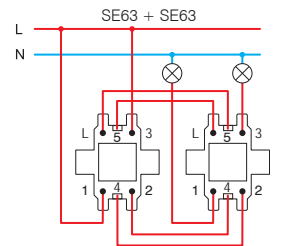
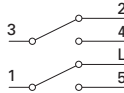

STIKALO KRIŽNO 10AX 250V~



SE70

- 10AX 250V~, tip SE70
 - ustreza EN 60669-1
 - brezvijačna pritrditev vodnikov 1.5-2.5mm²
- SWITCH INTERMEDIATE 10AX 250V~**
- 10AX 250V~, type SE70
 - in accordance with EN 60669-1
 - plug-in contacts 1.5-2.5mm²

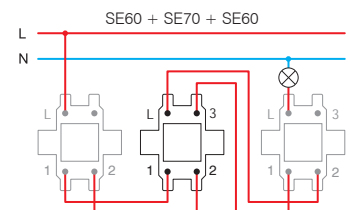

STIKALO ENOPOLNO 10AX 250V~



- SE10PW
- SE10IW
- SE10ES
- SE10CO
- SE10NB

- 10AX 250V~, tip SE10
- ustreza EN 60669-1
- brezvijačna pritrnitev vodnikov 1.5-2.5mm²

SWITCH 1WAY 10AX 250V~
 - 10AX 250V~, type SE10
 - in accordance with EN 60669-1
 - plug-in contacts 1.5-2.5mm²



STIKALO ENOPOLNO 10AX 250V~ __ IN



- SE10PWIN
- SE10IWIN
- SE10ESIN
- SE10COIN
- SE10NBIN

- IN indikator
- 10AX 250V~, tip SE10
- ustreza EN 60669-1
- brezvijačna pritrnitev vodnikov 1.5-2.5mm²

SWITCH 1WAY 10AX 250V~ __ IN
 - IN indikator
 - 10AX 250V~, type SE10
 - in accordance with EN 60669-1
 - plug-in contacts 1.5-2.5mm²



TIPKALO ENOPOLNO 10A 250V~



- SE11PW
- SE11IW
- SE11ES
- SE11CO
- SE11NB

- 10A 250V~, tip SE11
- ustreza EN 60669-1
- brezvijačna pritrnitev vodnikov 1.5-2.5mm²

PUSH BUTTON 1WAY 10A 250V~
 - 10A 250V~, type SE11
 - in accordance with EN 60669-1
 - plug-in contacts 1.5-2.5mm²



TIPKALO ENOPOLNO 10A 250V~ __ TI 50



- SE11PWTI50
- SE11IWTI50
- SE11ESTI50
- SE11COTI50
- SE11NBTI50

- TI 50 indikator zvonec+tlivka
- 10A 250V~, tip SE11
- ustreza EN 60669-1
- brezvijačna pritrnitev vodnikov 1.5-2.5mm²

PUSH BUTTON 1WAY 10A 250V~ __ TI 50
 - TI 50 indicator bell+neon lamp
 - 10A 250V~, type SE11
 - in accordance with EN 60669-1
 - plug-in contacts 1.5-2.5mm²



TIPKALO ENOPOLNO 10A 250V~ __ TI 51



- SE11PWTI51
- SE11IWTI51
- SE11ESTI51
- SE11COTI51
- SE11NBTI51

- TI 51 indikator luč+tlivka
- 10A 250V~, tip SE11
- ustreza EN 60669-1
- brezvijačna pritrnitev vodnikov 1.5-2.5mm²

PUSH BUTTON 1WAY 10A 250V~ __ TI 51
 - TI 51 indicator light+neon lamp
 - 10A 250V~, type SE11
 - in accordance with EN 60669-1
 - plug-in contacts 1.5-2.5mm²



TIPKALO ENOPOLNO 10A 250V~ __ IL



- SE11PWIL
- SE11IWIL
- SE11ESIL
- SE11COIL
- SE11NBIL

- IL napisna ploščica
- 10A 250V~, tip SE11
- ustreza EN 60669-1
- brezvijačna pritrnitev vodnikov 1.5-2.5mm²

PUSH BUTTON 1WAY 10A 250V~ __ IN 01
 - IL inscription plate
 - 10A 250V~, type SE11
 - in accordance with EN 60669-1
 - plug-in contacts 1.5-2.5mm²



STIKALO DVOPOLNO 16AX 250V~ __ NT 03



- SE22PWNT03
- SE22IWNT03
- SE22ESNT03
- SE22NBNT03

- NT 03 nevtral 0-1
- 16AX 250V~, tip SE22
- ustreza EN 60669-1
- vijajčna pritrnitev vodnikov 1.5-2.5mm²

SWITCH 2POLE 16AX 250V~ __ NT 03
 - NT 03 neutral 0-1
 - 16AX 250V~, type SE22
 - in accordance with EN 60669-1
 - screw contacts 1.5-2.5mm²



STIKALO SERIJSKO 10AX 250V~



- SE50PW
- SE50IW
- SE50ES
- SE50CO
- SE50NB

- 10AX 250V~, tip SE50
- ustreza EN 60669-1
- brezvijačna pritrditev vodnikov 1.5-2.5mm²

SWITCH 2GANG-1WAY 10AX 250V~
- 10AX 250V~, type SE50
- in accordance with EN 60669-1
- plug-in contacts 1.5-2.5mm²



TIPKALO SERIJSKO 10A 250V~



- SE51PW
- SE51IW
- SE51ES
- SE51CO
- SE51NB

- 10A 250V~, tip SE51
- ustreza EN 60669-1
- brezvijačna pritrditev vodnikov 1.5-2.5mm²

PUSH BUTTON 2GANG-1WAY 10A 250V~
- 10A 250V~, type SE51
- in accordance with EN 60669-1
- plug-in contacts 1.5-2.5mm²



STIKALO ŽALUZIJSKO 10AX 250V~ __ NT 09



- SE52PWNT09
- SE52IWNT09
- SE52ESNT09
- SE52CONT09
- SE52NBNT09

- NT 09 nevtral gor-dol
- 10AX 250V~, tip SE52, ustreza EN 60669-1
- brezvijačna pritrditev vodnikov 1.5-2.5mm²
- z mehansko blokado hkratnega vklopa

SWITCH SHUTTERS 10AX 250V~ __ NT 09
- NT 09 neutral up-down
- 10AX 250V~, type SE52
- in accordance with EN 60669-1
- plug-in contacts 1.5-2.5mm²
- with mechanical interblock



TIPKALO ŽALUZIJSKO 10A 250V~



- SE53PWNT09
- SE53IWNT09
- SE53ESNT09
- SE53CONT09
- SE53NBNT09

- NT 09 nevtral gor-dol
- 10A 250V~, tip SE53, ustreza EN 60669-1
- brezvijačna pritrditev vodnikov 1.5-2.5mm²
- z mehansko blokado hkratnega vklopa

PUSH BUTTON SHUTTERS 10A 250V~
- NT 09 neutral up-down
- 10A 250V~, type SE53
- in accordance with EN 60669-1
- plug-in contacts 1.5-2.5mm²
- with mechanical interblock



STIKALO MENJALNO 10AX 250V~



- SE60PW
- SE60IW
- SE60ES
- SE60CO
- SE60NB

- 10AX 250V~, tip SE60
- ustreza EN 60669-1
- brezvijačna pritrditev vodnikov 1.5-2.5mm²

SWITCH 2WAY 10AX 250V~
- 10AX 250V~, type SE60
- in accordance with EN 60669-1
- plug-in contacts 1.5-2.5mm²



STIKALO DVOJNO MENJALNO 10AX 250V~



- SE63PW
- SE63IW
- SE63ES
- SE63CO
- SE63NB

- 10AX 250V~, tip SE63
- ustreza EN 60669-1
- brezvijačna pritrditev vodnikov 1.5-2.5mm²

SWITCH DOUBLE 2WAY 10AX 250V~
- 10AX 250V~, type SE63
- in accordance with EN 60669-1
- plug-in contacts 1.5-2.5mm²



STIKALO KRIŽNO 10AX 250V~



- SE70PW
- SE70IW
- SE70ES
- SE70CO
- SE70NB

- 10AX 250V~, tip SE70
- ustreza EN 60669-1
- brezvijačna pritrditev vodnikov 1.5-2.5mm²

SWITCH INTERMEDIATE 10AX 250V~
- 10AX 250V~, type SE70
- in accordance with EN 60669-1
- plug-in contacts 1.5-2.5mm²

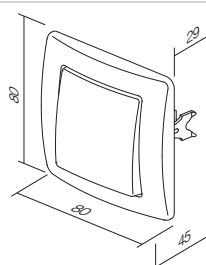
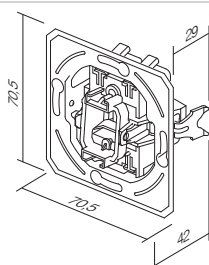

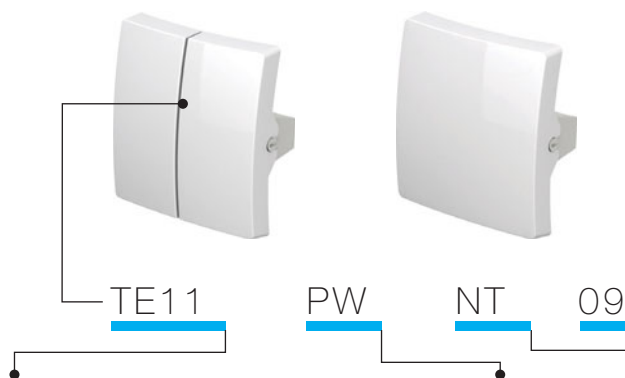

tip type	naziv description	barva colour	opcijski opis 1 optional data 1	opcijski opis 2 optional data 2
TE10	TIPKA NAVADNA BUTTON 1GANG	<input type="checkbox"/> PW bela-sijaj polar white <input type="checkbox"/> IW bež-sijaj ivory white <input type="checkbox"/> ES srebrna-mat elox silver <input type="checkbox"/> CO beli duroplast white thermoset <input type="checkbox"/> NB črna-sijaj night black	 NT nevtral neutral  IN indikator indication	 50  51  03  04
TE11	TIPKA SERIJSKA BUTTON 2GANG			

TIPKA NAVADNA



- TE10PW
- TE10IW
- TE10ES
- TE10CO
- TE10NB

- tipka skupaj z nosilcem
BUTTON 1GANG
- button together with carrier



TIPKA INDIKATOR



- TE10PWIN
- TE10IWIN
- TE10ESIN
- TE10COIN
- TE10NBIN

- tipka skupaj z nosilcem
BUTTON INDICATOR
- button together with carrier



TIPKA Z NAPISNO PLOŠČICO



- TE13PWIL
- TE13IWIL
- TE13ESIL
- TE13NBIL

- tipka skupaj z nosilcem, z napisno ploščico
BUTTON WITH INSCRIPTION PLATE
- button together with carrier, with inscription plate



TIPKA SERIJSKA



- TE11PW
- TE11IW
- TE11ES
- TE11CO
- TE11NB

- tipka serijska skupaj z nosilcem
BUTTON 2GANG
- button 2gang together with carrier

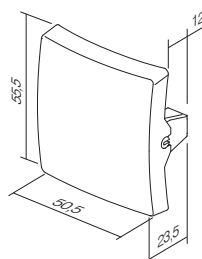
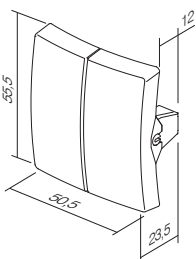

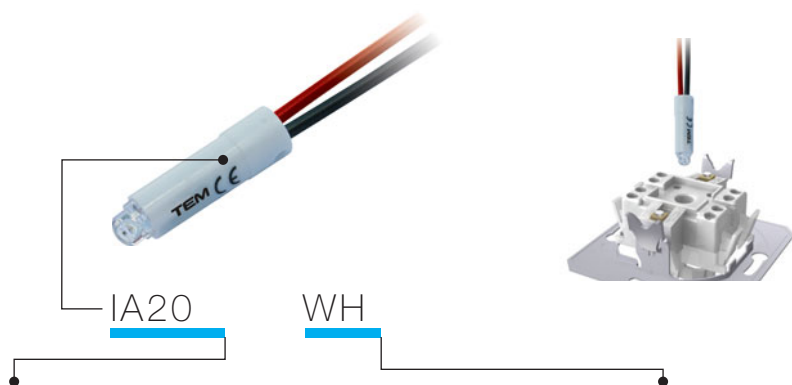

tip type	naziv description	tehnični opis technical data	barva colour
IA10	TLIVKA NEON LAMP	230V~ 0,34W	<input type="checkbox"/> WH bela white
IA20	SIJALKA LED LED LAMP	230V~ 0,40W	<input checked="" type="checkbox"/> BL modra blue
IA21	SIJALKA LED LED LAMP	24V AC/DC 0,20W	<input checked="" type="checkbox"/> RD rdeča red
.	.	.	<input checked="" type="checkbox"/> GR zelena green
.	.	.	<input checked="" type="checkbox"/> OR oranžna orange

TLIVKA 230V ~ 0,34W

 IA10OR

- za indikacijo, osvetlitev ali stalno osvetlitev stikala
- v kombinaciji s tipko z indikatorjem

NEON LAMP 230V ~ 0,34W
 - for indication, illumination or constant illumination of switch
 - in combination with button with indicator

SIJALKA LED 230V AC/DC 0,40W

 IA20WH
 IA20GR
 IA20RD
 IA20BL

- za indikacijo, osvetlitev ali stalno osvetlitev stikala
- v kombinaciji s tipko z indikatorjem

LED LAMP 230V AC/DC 0,40W
 - for indication, illumination or constant illumination of switch
 - in combination with button with indicator

SIJALKA LED 24V AC/DC 0,20W

 IA21WH
 IA21RD

- za indikacijo, osvetlitev ali stalno osvetlitev stikala
- v kombinaciji s tipko z indikatorjem

LED LAMP 24V AC/DC 0,20W
 - for indication, illumination or constant illumination of switch
 - in combination with button with indicator

SIJALKA LED 12V AC/DC 0,10W

 IA22WH
 IA22RD

- za indikacijo, osvetlitev ali stalno osvetlitev stikala
- v kombinaciji s tipko z indikatorjem

LED LAMP 12V AC/DC 0,10W
 - for indication, illumination or constant illumination of switch
 - in combination with button with indicator

Indikacija/ *
Indication

Osvetlitev/
Illumination

Stalna osvetlitev/ *
Illumination always on

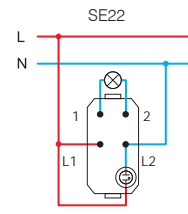
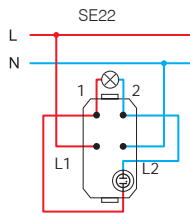
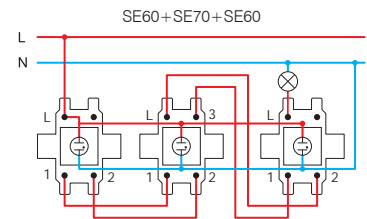
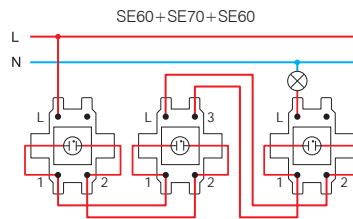
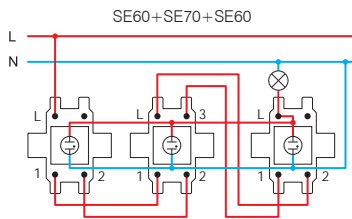
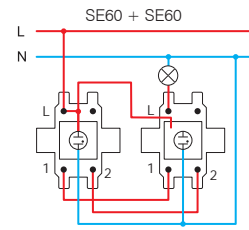
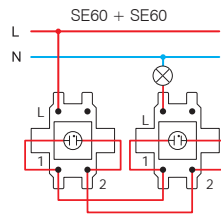
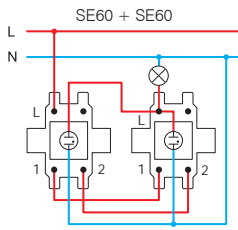
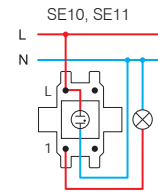
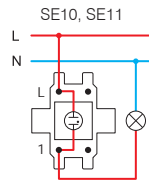
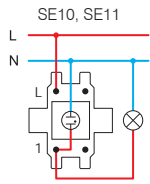

* vezave primerne za varčne (CFL) sijalke / wiring scheme for compact fluid lamp (CFL)

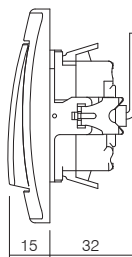

S O C K E T S V E

VE11 PT XO KS

tip type	naziv description	tehnični opis technical data	barva colour	opsijski opis 1 optional data 1	opsijski opis 2 optional data 2
VE10	VTIČNICA SCHUKO SOCKET SCHUKO	2P+E 16A 250V~		XO brez okvirja without cover plate	KS otroška zaščita child protection
VE11	VTIČNICA SCHUKO+POKROV SOCKET SCHUKO+COVER	2P+E 16A 250V~			
VE12	VTIČNICA SCHUKO SOCKET SCHUKO	2P+E 16A 250V~ BV		KS otroška zaščita child protection	

barva
colour

<input type="checkbox"/> PW bela-sijaj polar white	<input checked="" type="checkbox"/> PT bela+prozorna white+transparent	<input type="checkbox"/> PP bela+bela white+white
<input type="checkbox"/> IW bež-sijaj ivory white	<input checked="" type="checkbox"/> IT bež+prozorna ivory+transparent	<input type="checkbox"/> II bež+bež ivory+ivory
<input type="checkbox"/> ES srebrna-mat elox silver	<input checked="" type="checkbox"/> ST srebrna+prozorna silver+transparent	<input type="checkbox"/> SS srebrna+srebrna silver+silver
<input type="checkbox"/> CO beli duroplast white thermoset	<input checked="" type="checkbox"/> CT bela+prozorna white+transparent	<input type="checkbox"/> BB črna+črna black+black
<input checked="" type="checkbox"/> NB črna-sijaj night black	<input checked="" type="checkbox"/> BT črna+prozorna black+transparent	<input type="checkbox"/> RR rdeča+rdeča red+red
<input checked="" type="checkbox"/> RD rdeča red	<input checked="" type="checkbox"/> RT rdeča+prozorna red+transparent	<input type="checkbox"/> GG zelena+zelena green+green
<input checked="" type="checkbox"/> GR zelena green	<input checked="" type="checkbox"/> GT zelena+prozorna green+transparent	<input type="checkbox"/> OO oranžna+oranžna orange+orange
<input checked="" type="checkbox"/> OR oranžna orange	<input checked="" type="checkbox"/> OT oranžna+prozorna orange+transparent	



schuko - ustreza EN 60884-1, CEE7 (list III)

francoska - ustreza NF C 61-314 (list V)

schuko - in accordance with EN 60884-1, CEE7 (standard sheet III)

French - in accordance with NF C 61-314 (standard sheet V)



VTIČNICA SCHUKO 2P+E 16A 250V~ __ XO



- VE10PWXO
- VE10IWXO
- VE10ESXO
- VE10COXO
- VE10NBXO
- VE10RDXO
- VE10GRXO
- VE10ORXO

- vijačna pritrditev vodnikov 1.5-2.5mm²
 - XO brez okvirja
 - 2P+E schuko
 - 16A 250V~, tip VE10

SOCKET SCHUKO 2P+E 16A 250V~ __ XO

- screw contacts 1.5-2.5mm²
 - XO without surround
 - 2P+E schuko
 - 16A 250V~, type VE10



VTIČNICA SCHUKO+POKROV 2P+E 16A 250V~ __ XO



- VE11PTXO
- VE11ITXO
- VE11STXO
- VE11BTXO

- vijačna pritrditev vodnikov 1.5-2.5mm²
 - XO brez okvirja
 - 2P+E schuko+pokrov
 - 16A 250V~, tip VE11

SOCKET SCHUKO+COVER 2P+E 16A 250V~ __ XO

- screw contacts 1.5-2.5mm²
 - XO without surround
 - 2P+E schuko+cover
 - 16A 250V~, type VE11



VTIČNICA SCHUKO 2P+E 16A 250V~ BV __ XO



- VE12PWXO
- VE12IWXO
- VE12ESXO
- VE12COXO
- VE12NBXO
- VE12RDXO
- VE12GRXO
- VE12ORXO

- BV brezvijačna pritrditev vodnikov 1.5-2.5mm²
 - XO brez okvirja
 - 2P+E schuko
 - 16A 250V~, tip VE12

SOCKET SCHUKO 2P+E 16A 250V~ BV __ XO

- BV plug-in contacts 1.5-2.5mm²
 - XO without surround
 - 2P+E schuko
 - 16A 250V~, type VE12



VTIČNICA SCHUKO+POKROV 2P+E 16A 250V~ BV __ XO



- VE13PTXO
- VE13ITXO
- VE13STXO
- VE13BTXO
- VE13PPXO

- BV brezvijačna pritrditev vodnikov 1.5-2.5mm²
 - XO brez okvirja
 - 2P+E schuko+pokrov
 - 16A 250V~, tip VE13

SOCKET SCHUKO+COVER 2P+E 16A 250V~ BV __ XO

- BV plug-in contacts 1.5-2.5mm²
 - XO without surround
 - 2P+E schuko+cover
 - 16A 250V~, type VE13



VTIČNICA SCHUKO 2P+E 16A 250V~



- VE10PW
- VE10IW
- VE10ES
- VE10CO
- VE10NB

- vijačna pritrditev vodnikov 1.5-2.5mm²
 - 2P+E schuko
 - 16A 250V~, tip VE10

SOCKET SCHUKO 2P+E 16A 250V~

- screw contacts 1.5-2.5mm²
 - 2P+E schuko
 - 16A 250V~, type VE10



VTIČNICA SCHUKO+POKROV 2P+E 16A 250V~



- VE11PT
- VE11IT
- VE11ST
- VE11CT
- VE11BT

- vijačna pritrditev vodnikov 1.5-2.5mm²
 - 2P+E schuko+pokrov
 - 16A 250V~, tip VE11

SOCKET SCHUKO+COVER 2P+E 16A 250V~

- screw contacts 1.5-2.5mm²
 - 2P+E schuko+cover
 - 16A 250V~, type VE11



VTIČNICA SCHUKO 2P+E 16A 250V~ BV



- VE12PW
- VE12IW
- VE12ES
- VE12CO
- VE12NB

- BV brezvijačna pritrditev vodnikov 1.5-2.5mm²
 - 2P+E schuko
 - 16A 250V~, tip VE12

SOCKET SCHUKO 2P+E 16A 250V~ BV

- BV plug-in contacts 1.5-2.5mm²
 - 2P+E schuko
 - 16A 250V~, type VE12



VTIČNICA SCHUKO+POKROV 2P+E 16A 250V~ BV



- VE13PT
- VE13IT
- VE13ST
- VE13CT
- VE13BT

- BV brezvijačna pritrditev vodnikov 1.5-2.5mm²
 - 2P+E schuko+pokrov
 - 16A 250V~, tip VE13

SOCKET SCHUKO+COVER 2P+E 16A 250V~ BV

- BV plug-in contacts 1.5-2.5mm²
 - 2P+E schuko+cover
 - 16A 250V~, type VE13



VTIČNICA FRANCOSKA 2P+E 16A 250V~ __ XO

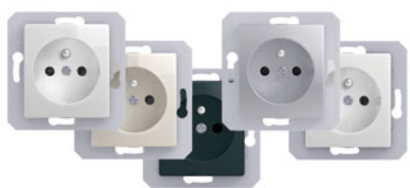

- VE40PWXO
- VE40IWXO
- VE40ESXO
- VE40COXO
- VE40NBXO
- VE40RDXO
- VE40GRXO
- VE40ORXO

- vijačna pritrditev vodnikov 1.5-2.5mm²
- XO brez okvirja
- 2P+E francoska
- 16A 250V~, tip VE40

SOCKET FRENCH 2P+E 16A 250V~ __ XO

- screw contacts 1.5-2.5mm²
- XO without surround
- 2P+E French
- 16A 250V~, type VE40



VTIČNICA FRANCOSKA+POKROV 2P+E 16A 250V~ __ XO



- VE41PTXO
- VE41ITXO
- VE41STXO
- VE41PTXO
- VE41BTXO
- VE41PPXO

- vijačna pritrditev vodnikov 1.5-2.5mm²
- XO brez okvirja
- 2P+E francoska+pokrov
- 16A 250V~, tip VE41

SOCKET FRENCH+COVER 2P+E 16A 250V~ __ XO

- screw contacts 1.5-2.5mm²
- XO without surround
- 2P+E French+cover
- 16A 250V~, type VE41



VTIČNICA FRANCOSKA 2P+E 16A 250V~ BV __ XO



- VE42PWXO
- VE42IWXO
- VE42ESXO
- VE42COXO
- VE42NBXO
- VE42RDXO
- VE42GRXO
- VE42ORXO

- BV brezvijačna pritrditev vodnikov 1.5-2.5mm²
- XO brez okvirja
- 2P+E francoska
- 16A 250V~, tip VE42

SOCKET FRENCH 2P+E 16A 250V~ BV __ XO

- BV plug-in contacts 1.5-2.5mm²
- XO without surround
- 2P+E French
- 16A 250V~, type VE42



VTIČNICA FRANCOSKA+POKROV 2P+E 16A 250V~ BV __ XO



- VE43PTXO
- VE43ITXO
- VE43STXO
- VE43PTXO
- VE43BTXO
- VE43PPXO

- BV brezvijačna pritrditev vodnikov 1.5-2.5mm²
- XO brez okvirja
- 2P+E francoska+pokrov
- 16A 250V~, tip VE43

SOCKET FRENCH+COVER 2P+E 16A 250V~ BV __ XO

- BV plug-in contacts 1.5-2.5mm²
- XO without surround
- 2P+E French+cover
- 16A 250V~, type VE43



VTIČNICA FRANCOSKA 2P+E 16A 250V~



- VE40PW
- VE40IW
- VE40ES
- VE40CO
- VE40NB

- vijačna pritrditev vodnikov 1.5-2.5mm²
- 2P+E francoska
- 16A 250V~, tip VE40

SOCKET FRENCH 2P+E 16A 250V~

- screw contacts 1.5-2.5mm²
- 2P+E French
- 16A 250V~, type VE40



VTIČNICA FRANCOSKA+POKROV 2P+E 16A 250V~



- VE41PT
- VE41IT
- VE41ST
- VE41CT
- VE41BT

- vijačna pritrditev vodnikov 1.5-2.5mm²
- 2P+E francoska+pokrov
- 16A 250V~, tip VE41

SOCKET FRENCH+COVER 2P+E 16A 250V~

- screw contacts 1.5-2.5mm²
- 2P+E French+cover
- 16A 250V~, type VE41



VTIČNICA FRANCOSKA 2P+E 16A 250V~ BV



- VE42PW
- VE42IW
- VE42ES
- VE42CO
- VE42NB

- BV brezvijačna pritrditev vodnikov 1.5-2.5mm²
- 2P+E francoska
- 16A 250V~, tip VE42

SOCKET FRENCH 2P+E 16A 250V~ BV

- BV plug-in contacts 1.5-2.5mm²
- 2P+E French
- 16A 250V~, type VE42



VTIČNICA FRANCOSKA+KS+POKROV 2P+E 16A 250V~ BV



- VE43PT
- VE43IT
- VE43ST
- VE43CT
- VE43BT

- BV brezvijačna pritrditev vodnikov 1.5-2.5mm²
- 2P+E francoska+pokrov
- 16A 250V~, tip VE43

SOCKET FRENCH+COVER 2P+E 16A 250V~ BV

- BV plug-in contacts 1.5-2.5mm²
- 2P+E French+cover
- 16A 250V~, type VE43



VTIČNICA SCHUKO DVOJNA 2P+E 16A 250V~



- VE16PWKS
- VE16IWKS
- VE16ESKS
- VE16SBKS

- 2P+E schuko dvojna
- 16A 250V~, tip VE16
- ustreza IEC 60884-1, CEE7
- vijačna pritrditev vodnikov 1.5-2.5 mm²
- KS vgrajena otroška zaščita pred dotikom kontaktov

SOCKET SCHUKO DOUBLE 2P+E 16A 250V~

- 2P+E schuko double
- 16A 250V~, type VE16
- in accordance with IEC 60884-1, CEE7
- screw contacts 1.5-2.5 mm²
- KS build-in child protection – shuttered live contacts



VTIČNICA FRANCOŠKA DVOJNA 2P+E 16A 250V~



- VE46PWKS
- VE46SBKS
- VE46ESKS
- VE46IWKS

- 2P+E francoska dvojna
- 16A 250V~, tip VE46
- ustreza IEC 60884-1, CEE7; NF C 61-314, ČSN 33 2318; PN-E 93201
- vijačna pritrditev vodnikov 1,5-2,5 mm²
- KS vgrajena otroška zaščita pred dotikom kontaktov

SOCKET FRENCH DOUBLE 2P+E 16A 250V~

- 2P+E French double
- 16A 250V~, type VE46
- in accordance with IEC 60884-1, CEE7; NF C 61-314, ČSN 33 2318; PN-E 93201
- screw contacts 1,5-2,5 mm²
- KS build-in child protection – shuttered live contacts



VTIČNICA 2P 16A 250V~



- VE30PW
- VE30IW
- VE30ES
- VE30NB

- 2P brez ozemljitvenega kontakta
- 16A 250V~
- ustreza EN 60884-1, CEE7 (list I)
- vijačna pritrditev vodnikov 1.5-2.5mm²

SOCKET 2P 16A 250V~

- 2P without earthing contact
- 16A 250V~
- in accordance with EN 60884-1, CEE7 (standard sheet I)
- screw contacts 1.5-2.5mm²

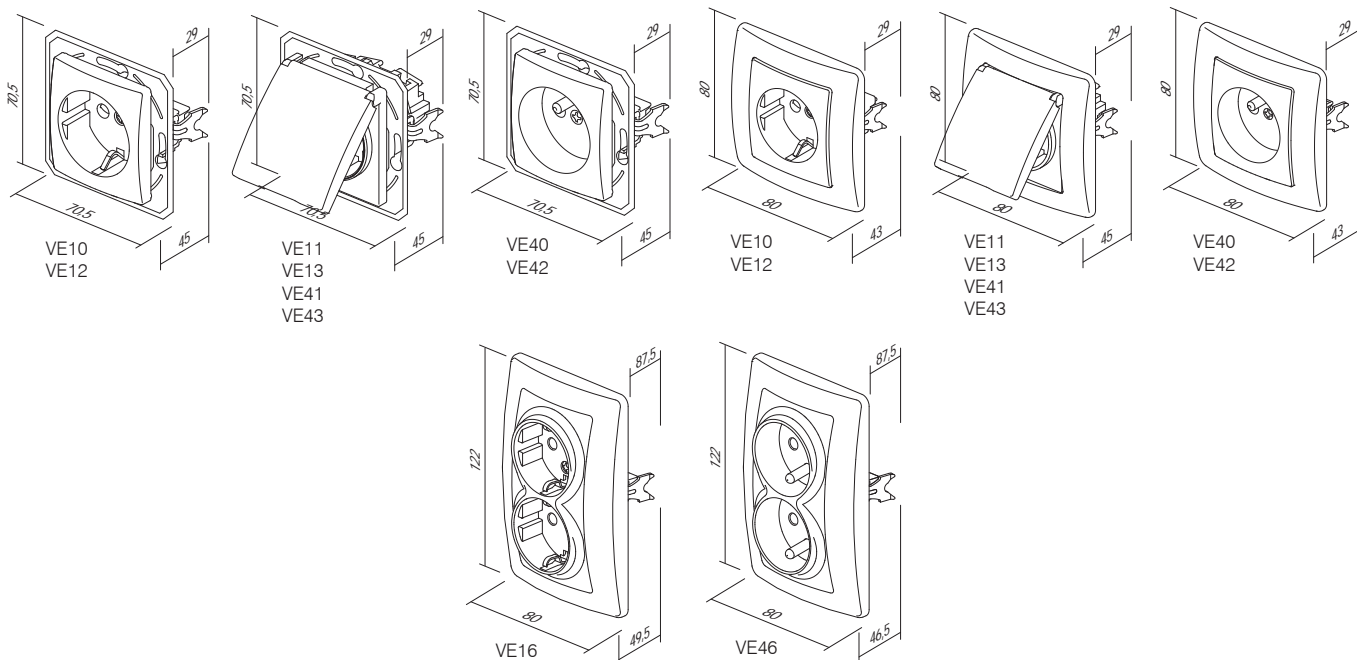

KE37

PW

tip type	naziv description	tehnični opis technical data	barva colour
KE11	VTIČNICA TV-R KONČNA SOCKET TV-R END-LINE	2dB	<input type="checkbox"/> PW bela-sijaj polar white
KE12	VTIČNICA TV-R PREHODNA SOCKET TV-R THROUGHPASS	8,5dB	<input type="checkbox"/> IW bež-sijaj ivory white
KE16	VTIČNICA SAT-TV-R KONČNA SOCKET SAT-TV-R END-LINE	3dB	<input type="checkbox"/> ES srebrna-mat elox silver <input type="checkbox"/> CO beli duroplast white thermoset <input type="checkbox"/> NB črna-sijaj night black

VTIČNICA TV-R KONČNA 2dB



KE11

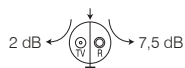

- TV-R končna
- frekvenčni pas 5 – 862MHz
- dušenje: R-7.5dB, TV-2dB
- ustreza EN 50083-1
- vijačna priključitev

SOCKET TV-R END-LINE 2dB

- TV-R end-line
- frequency range 5 – 862MHz
- reduction: R-7.5dB, TV-2dB
- in accordance with EN 50083-1
- screw contacts

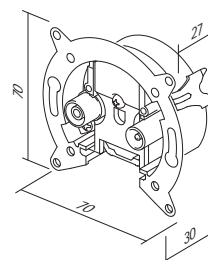

VTIČNICA TV-R PREHODNA 8,5dB



KE12

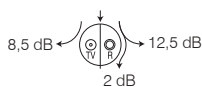

- TV-R prehodna vtičnica
- frekvenčni pas 5 – 862MHz
- dušenje: R-12.5dB, TV-8.5dB, prehod-2dB
- ustreza EN 50083-1
- vijačna priključitev

SOCKET TV-R TROUGHPASS 8,5dB

- TV-R troughpass
- frequency range 5 – 862MHz
- reduction: R-12.5dB, TV-8.5dB, trough-2dB
- in accordance with EN 50083-1
- screw contacts

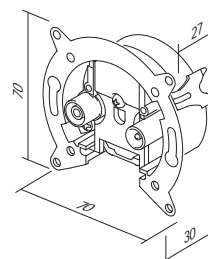

VTIČNICA SAT-TV-R KONČNA 3dB



KE16

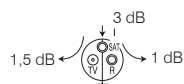

- SAT-TV-R končna
- frekvenčni pas 5 – 2400MHz
- dušenje: R-1dB, TV-1.5dB, SAT-3dB
- vgradjna v dozo Ø60 s krempljci ali vijaki
- ustreza EN 50083-1
- vijačna pritrditev vodnikov

SOCKET SAT-TV-R END-LINE 3dB

- SAT-TV-R end-line
- frequency range 5 – 2400MHz
- reduction: R-1dB, TV-1.5dB, SAT-3dB
- for mounting in round box Ø60 with claws or screws
- in accordance with EN 50083-1
- screw contacts

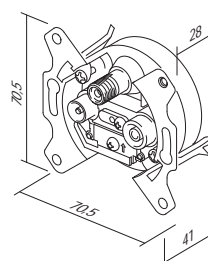

VTIČNICA TEL KS RJ11 6/4



KE36

- KS keystone pritrditveni standard
- RJ11 6/4
- ustreza IEC 60603-7

SOCKET TEL KS RJ11 6/4

- KS keystone fixing standard
- RJ11 6/4
- in accordance with IEC 60603-7

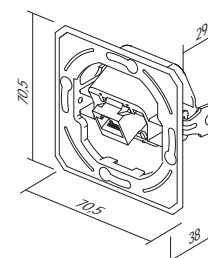



KE37

VTIČNICA CAT5e KS RJ45 8/8

- KS keystone pritrditveni standard
- CAT5e, RJ45 8/8
- ustreza IEC 60603-7

SOCKET CAT5e KS RJ45 8/8

- KS keystone fixing standard
- CAT5e, RJ45 8/8
- in accordance with IEC 60603-7

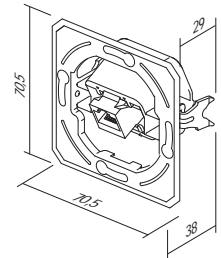

KE38

VTIČNICA TEL KS DVOJNA 2x RJ11 6/4

- KS keystone pritrditveni standard
- 2x RJ11 6/4
- ustreza IEC 60603-7

SOCKET TEL KS DOUBLE 2x RJ11 6/4

- KS keystone fixing standard
- 2x RJ11 6/4
- in accordance with IEC 60603-7

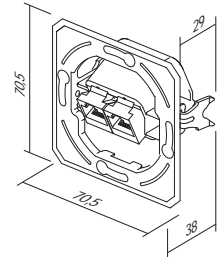

KE39

VTIČNICA CAT5e KS DVOJNA 2x RJ45 8/8

- KS keystone pritrditveni standard
- 2x CAT5e, RJ45 8/8
- ustreza IEC 60603-7

SOCKET CAT5e KS DOUBLE 2x RJ45 8/8

- KS keystone fixing standard
- 2x CAT5e, RJ45 8/8
- in accordance with IEC 60603-7

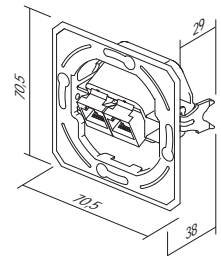

ADAPTER KS ENOJNI



KE45

- KS keystone pritrditveni standard - enojni
- AMP, Avaya, Brandrex, FMT, Mfico, Tyco, ...
- komunikacijski modul ni vgrajen

ADAPTER KS SINGLE

- KS keystone fixing standard - single
- AMP, Avaya, Brandrex, FMT, Mfico, Tyco, ...
- communication module not included

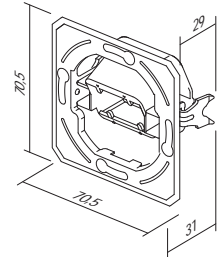

ADAPTER KS DVOJNI



KE46

- KS keystone pritrditveni standard - dvojni
- AMP, Tyco, ...
- komunikacijski modul ni vgrajen

ADAPTER KS DOUBLE

- KS keystone fixing standard - double
- AMP, Tyco, ...
- communication module not included

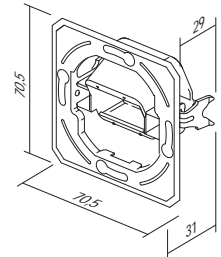

ADAPTER PD DVOJNI



KE47

- PD Panduit MiniCOM pritrditveni standard - dvojni
- komunikacijski modul ni vgrajen

ADAPTER PD DOUBLE

- PD Panduit Mini-COM fixing standard - double
- communication module not included

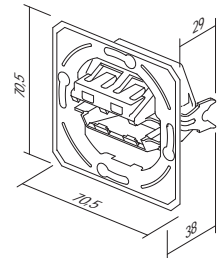

VTIČNICA TV OSNOVNA 0dB



- KE10PW
- KE10IW
- KE10ES
- KE10CO
- KE10NB

- TV osnovna
 - dušenje 0dB
 - konektor zadaj – F standard
- SOCKET TV BASIC 0dB**
- TV basic
 - reduction 0dB
 - back connector – F standard



VTIČNICA TV-R KONČNA 2dB



- KE11PW
- KE11IW
- KE11ES
- KE11CO
- KE11NB

- TV-R končna
 - frekvenčni pas 5–862 MHz
 - dušenje: R-7.5dB, TV-2dB
 - ustreza EN 50083-1
 - vijačna priključitev
- SOCKET TV-R END-LINE 2dB**
- TV-R end-line
 - frequency range 5–862 MHz
 - reduction: R-7.5dB, TV-2dB
 - in accordance with EN 50083-1
 - screw contact



VTIČNICA TV-R PREHODNA 8,5dB



- KE12PW
- KE12IW
- KE12ES
- KE12CO
- KE12NB

- TV-R prehodna
 - frekvenčni pas 5–862 MHz
 - dušenje: R-12.5dB, TV-8.5dB, prehod-2dB
 - ustreza EN 50083-1
 - vijačna priključitev
- SOCKET TV-R TROUGHPASS 8,5dB**
- TV-R troughpass
 - frequency range 5–862 MHz
 - reduction: R-12.5dB, TV-8.5dB, trough-2dB
 - in accordance with EN 50083-1
 - screw contacts



VTIČNICA SAT-TV-R KONČNA 3dB



- KE16PW
- KE16IW
- KE16ES
- KE16CO
- KE16NB

- SAT-TV-R končna
 - frekvenčni pas 5–2400 MHz
 - dušenje: R-1dB, TV-1.5dB, SAT-3dB
 - ustreza EN 50083-1
 - vijačna priključitev
- SOCKET SAT-TV-R END-LINE 3dB**
- SAT-TV-R end-line
 - frequency range 5–2400 MHz
 - reduction: R-1dB, TV-1.5dB, SAT-3dB
 - in accordance with EN 50083-1
 - screw contacts



VTIČNICA AVDIO 2xRCA



- KE22PW
- KE22IW
- KE22ES
- KE22CO
- KE22NB

- avdio 2xRCA
 - pritrditev vodnikov s spajkanjem
- SOCKET AUDIO 2xRCA**
- audio 2xRCA
 - soldering connection of cable



VTIČNICA AVDIO ZVOČNIŠKA



- KE23PW
- KE23IW
- KE23ES
- KE23CO
- KE23NB

- avdio 2x Ø4mm
 - za prikllop zvočniškega vodnika, vtiča Ø4mm ali viličastega kabel čevlja
 - pritrditev vodnikov zadaj s spajkanjem
- SOCKET AUDIO LOUDSPEAKERS**
- audio 2x Ø4mm
 - to accommodate speaker wire, banana plug Ø4mm or spades
 - soldering connection of cable at the back side



VTIČNICA TEL KS RJ11 6/4



- KE36PW
- KE36IW
- KE36ES
- KE36CO
- KE36NB

- KS keystone pritrditveni standard
- RJ11 6/4
- ustreza IEC 60603-7

SOCKET KS RJ11 6/4
- KS keystone fixing standard
- RJ11 6/4
- in accordance with IEC 60603-7



VTIČNICA CAT5e KS RJ45 8/8



- KE37PW
- KE37IW
- KE37ES
- KE37CO
- KE37NB

- KS keystone pritrditveni standard
- CAT5e, RJ45 8/8
- ustreza IEC 60603-7

SOCKET CAT5e KS RJ45 8/8
- KS keystone fixing standard
- CAT5e, RJ45 8/8
- in accordance with IEC 60603-7



VTIČNICA TEL KS DVOJNA 2x RJ11 6/4



- KE38PW
- KE38IW
- KE38ES
- KE38CO
- KE38NB

- KS keystone pritrditveni standard
- 2x RJ11, 6/4
- ustreza IEC 60603-7

SOCKET TEL KS DOUBLE 2x RJ11 6/4
- KS keystone fixing standard
- 2x RJ11, 6/4
- in accordance with IEC 60603-7



VTIČNICA CAT5e KS DVOJNA 2x RJ45 8/8



- KE39PW
- KE39IW
- KE39ES
- KE39CO
- KE39NB

- KS keystone pritrditveni standard
- 2x CAT5e, RJ45 8/8
- ustreza IEC 60603-7

SOCKET CAT5e KS DOUBLE 2x RJ45 8/8
- KS keystone fixing standard
- 2x CAT5e, RJ45 8/8
- in accordance with IEC 60603-7



VTIČNICA TEL LT RJ11 6/4



- KE35PW
- KE35IW
- KE35ES
- KE35CO
- KE35NB

- TEL LT vijak
- vijačna pritrditev vodnikov
- RJ11 6/4
- ustreza IEC 60603-7

SOCKET TEL LT RJ11 6/4
- TEL LT screw
- screw contacts
- RJ11 6/4
- in accordance with IEC 60603-7

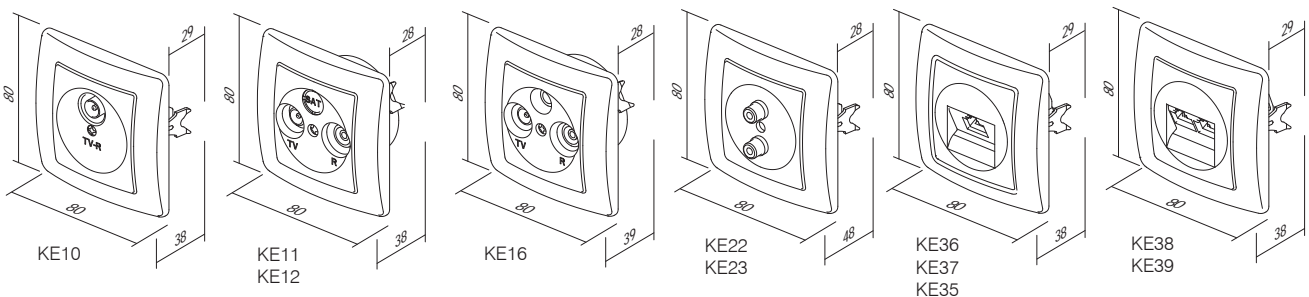

P O K R O V I K O M U N I K A C I J E K E

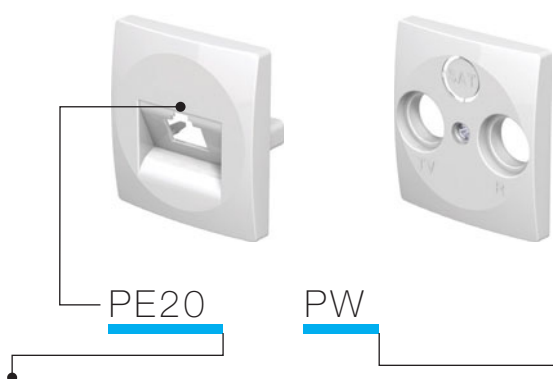

tip type	naziv description	tehnični opis technical data	barva colour
PE10	POKROV TV-R COVER TV-R	2P/3P	<input type="checkbox"/> PW bela-sijaj polar white
PE20	POKROV KS ENOJNI COVER KS SINGLE		<input type="checkbox"/> IW bež-sijaj ivory white
PE21	POKROV KS DVOJNI COVER KS DOUBLE		<input type="checkbox"/> ES srebrna-mat elox silver
...	<input type="checkbox"/> CO beli duroplast white thermoset
...	<input type="checkbox"/> NB črna-sijaj night black

POKROV TV-R 2P/3P



- PE10PW
- PE10IW
- PE10ES
- PE10CO
- PE10NB

- TV-R pokrov, 2P ali 3P z vijakom
COVER TV-R 2P/3P

- TV-R cover, 2P or 3P with screw



POKROV KS ENOJNI



- PE20PW
- PE20IW
- PE20ES
- PE20CO
- PE20NB

- KS pokrov enojni

COVER KS SINGLE

- KS cover single



POKROV KS DVOJNI

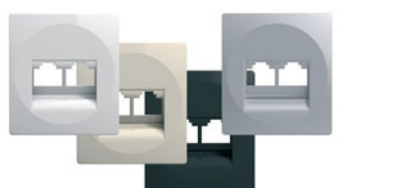

- PE21PW
- PE21IW
- PE21ES
- PE21NB

- KS pokrov dvojni

COVER KS DOUBLE

- KS cover double



POKROV TAE/TDO

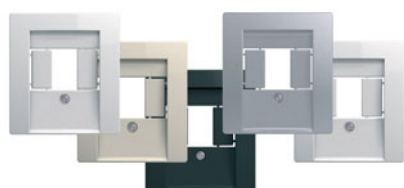

- PE30PW
- PE30IW
- PE30ES
- PE30CO
- PE30NB

- TAE ali TDO pokrov z vijakom

COVER TAE/TDO

- TAE or TDO cover with screw

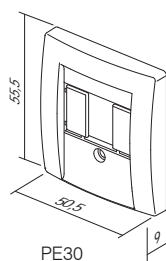

PE30

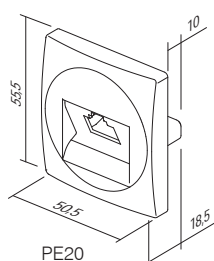

PE20

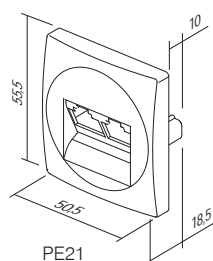

PE21

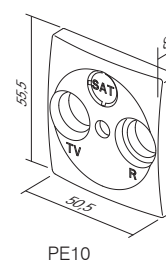

PE10



EE15

PW

tip type	naziv description	tehnični opis technical data	barva colour
EE15	ZATEMNILNIK ROTACIJSKI MEN DIMMER ROTATIVE 2WAY	RL 400W	<input type="checkbox"/> PW bela-sijaj polar white
EE16	ZATEMNILNIK ROTACIJSKI MEN DIMMER ROTATIVE 2WAY	RLC 400W	<input type="checkbox"/> IW bež-sijaj ivory white
EE17	ZATEMNILNIK ROTACIJSKI DIMMER ROTATIVE	FAN 600VA	<input type="checkbox"/> ES srebrna-mat elox silver
.	.	.	<input type="checkbox"/> CO beli duroplast white thermoset
.	.	.	<input type="checkbox"/> NB črna-sijaj night black

ZATEMNILNIK ROTACIJSKI MEN RL 400W



EE15

- rotacijski z menjalnim stikalom
 - breme RL, 40W - 400W
 - možna vezava z menjalnim stikalom
 - vezava večih zatemnilnikov ni dovoljena
 - ustreza EN 60669-1 in EN 60669-2-1
 - brezvijačna pritrditev vodnikov 1.5mm²
 - napajanje 230V~ 50Hz
 - premer nastavka gumba Ø6mm
 - zamenljiva varovalka vključena
- DIMMER ROTATIVE 2WAY RL 400W**
- rotation control with 2-way switch
 - load RL, 40W - 400W
 - 2-way switch combination is possible
 - more dimmers combination is not allowed
 - in accordance with EN 60669-1 and EN 60669-2-1
 - plug-in contacts 1.5mm²
 - supply 230V~ 50Hz
 - button inner diameter Ø6mm
 - replaceable fuse included

ZATEMNILNIK ROTACIJSKI MEN RLC 400W



EE16

- rotacijski z menjalnim stikalom
 - breme RLC, 20W - 400W
 - možna vezava z menjalnim stikalom
 - vezava večih zatemnilnikov ni dovoljena
 - ustreza EN 60669-1 in EN 60669-2-1
 - brezvijačna pritrditev vodnikov 1.5mm²
 - napajanje 230V~ 50Hz
 - premer nastavka gumba Ø6mm
 - elektronska varovalka
- DIMMER ROTATIVE 2WAY RLC 400W**
- rotation control with 2-way switch
 - load RLC, 20W - 400W
 - 2-way switch combination is possible
 - more dimmers combination is not allowed
 - in accordance with EN 60669-1 and EN 60669-2-1
 - plug-in contacts 1.5mm²
 - button inner diameter Ø6mm
 - supply 230V~ 50Hz
 - electronic fuse

ZATEMNILNIK ROTACIJSKI VENTILATOR 600VA

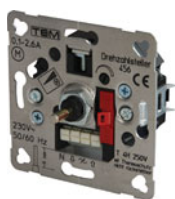

EE17

- rotacijski s stikalom
- tip 456; breme: motor, 25VA - 600VA
- vezava z menjalnim stikalom ni možna
- vezava večih zatemnilnikov ni dovoljena
- ustreza EN 60669-1 in EN 60669-2-1
- brezvijačna pritrditev vodnikov 1.5mm²
- napajanje 230V~ 50Hz
- premer nastavka gumba Ø4mm
- zamenljiva varovalka vključena

DIMMER ROTATIVE FAN 600VA

- rotation control with switch
- type 456: load: motor, 25VA - 600VA
- 2-way switch combination is not possible
- more dimmers combination is not allowed
- in accordance with EN 60669-1 and EN 60669-2-1
- plug-in contacts 1.5mm²
- supply 230V~ 50Hz
- button inner diameter Ø4mm
- replaceable fuse included

ZATEMNILNIK ROTACIJSKI MEN LED 100W



EE19

- rotacijski z menjalnim stikalom
- breme: LED, 0-100W (max. 10 LED sijalk) GLS, 10-250W
- možna vezava z menjalnim stikalom
- vezava več zatemnilnikov ni dovoljena
- ustreza EN 60669-1 in EN 60669-2-1
- brezvijačna pritrditev vodnikov 1,5 mm²
- napajanje 230V~ 50 Hz
- zamenljiva varovalka vključena
- premer nastavka gumba Ø6mm

DIMMER ROTATIVE 2WAY LED 100W

- rotation control with 2-way switch
- load: LED, 0-100W (max. 10 LEDs) GLS, 10-250W
- 2-way switch combination is possible
- more dimmers combination is not allowed
- in accordance with EN 60669-1 and EN 60669-2-1
- plug-in contacts 1.5mm²
- supply 230V~ 50Hz
- replaceable fuse included
- button inner diameter Ø6mm

ZATEMNILNIK ROTACIJSKI MEN RL 400W



- EE15PW
- EE15IW
- EE15ES
- EE15CO
- EE15NB

- rotacijski z menjalnim stikala
- breme RL, 40W - 400W
- možna vezava z menjalnim stikalom
- vezava večih zatemnilnikov ni dovoljena
- ustreza EN 60669-1 in EN 60669-2-1
- brezvijačna pritrditev vodnikov 1.5mm²
- napajanje 230V~ 50Hz
- zamenljiva varovalka vključena

DIMMER ROTATIVE 2WAY RL 400W

- rotation control with 2-way switch
- load RL, 40W - 400W
- 2-way switch combination is possible
- more dimmers combination is not allowed
- in accordance with EN 60669-1 and EN 60669-2-1
- plug-in contacts 1.5mm²
- supply 230V~ 50Hz
- replaceable fuse included



ZATEMNILNIK ROTACIJSKI MEN RLC 400W



- EE16PW
- EE16IW
- EE16ES
- EE16CO
- EE16NB

- rotacijski z menjalnim stikalom
- breme RLC, 20W - 400W
- možna vezava z menjalnim stikalom
- vezava večih zatemnilnikov ni dovoljena
- ustreza EN 60669-1 in EN 60669-2-1
- brezvijačna pritrditev vodnikov 1.5mm²
- napajanje 230V~ 50Hz
- elektronska varovalka

DIMMER ROTATIVE 2WAY RLC 400W

- rotation control with 2-way switch
- load RLC, 20W - 400W
- 2-way switch combination is possible
- more dimmers combination is not allowed
- in accordance with EN 60669-1 and EN 60669-2-1
- plug-in contacts 1.5mm²
- supply 230V~ 50Hz
- electronic fuse



ZATEMNILNIK ROTACIJSKI MEN LED 100W



- EE19PW
- EE19IW
- EE19ES
- EE19CO
- EE19NB

- rotacijski z menjalnim stikalom
- breme: LED, 0-100W (max. 10 LED sijalk)
GLS, 10-250W
- možna vezava z menjalnim stikalom
- vezava več zatemnilnikov ni dovoljena
- ustreza EN 60669-1 in EN 60669-2-1
- brezvijačna pritrditev vodnikov 1,5 mm²
- napajanje 230V~ 50 Hz
- zamenljiva varovalka vključena

*DIMMER ROTATIVE 2WAY LED 100W*

- rotation control with 2-way switch
- load: LED, 0-100W (max. 10 LEDs)
GLS, 10-250W
- 2-way switch combination is possible
- more dimmers combination is not allowed
- in accordance with EN 60669-1 and EN 60669-2-1
- plug-in contacts 1.5mm²
- supply 230V~ 50Hz
- replaceable fuse included

IR STIKALO 5A 250V~



- EE32PW
- EE32IW
- EE32ES
- EE32CO
- EE32NB

- IR infrardeče stikalo
- napajanje: 230V~ ± 10 % 50Hz
- rele: 5A / 250V~ izhod za omejen tok z visokim uporom za zero crossing
- stopnja varnosti: IP40
- presek žic pri stičniku: 0,75 - 2,5 mm²
- kot zaznavanja: do 110° pri 20°C
- območje zaznavanja: približno 8 m pri 20°C
- nastavljivost časovnega trajanja: od približno 5 s do 12 min
- nastavljivost osvetlitve: od približno 5 do 200 LUX
- temperatura delovanja: od 0°C do +40°C
- ni primeren za vgradnjo v doze, globine 45 mm
- samo za notranjo uporabo

*IR SWITCH 5A 250V~*

- IR infrared switch
- supply voltage: 230V~ ± 10 % 50Hz
- relay: 5A / 250V~ output for limited current with high resistance for zero crossing
- protection rating: IP40
- cross-section of wires at the contact terminal: 0.75 - 2.5 mm²
- detection angle: up to 110° at 20°C
- detection area: approx. 8 m at 20°C
- adjustability of duration: from approx. 5 s to 12 min
- adjustability of brightness: from approx. 5 to 200 LUX
- operating temperature: from 0°C to +40°C
- not suitable for installation in 45 mm deep boxes
- only for indoor usage

EE15, EE16, EE19

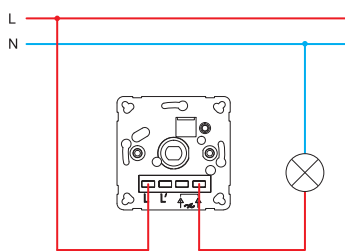

EE15, EE16, EE19

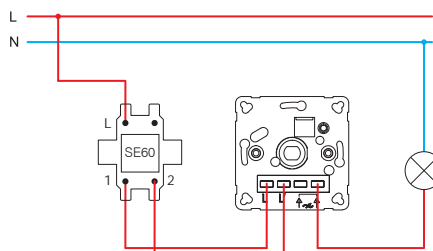

EE15, EE16, EE19

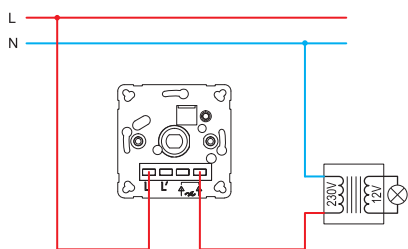

EE15, EE16, EE19

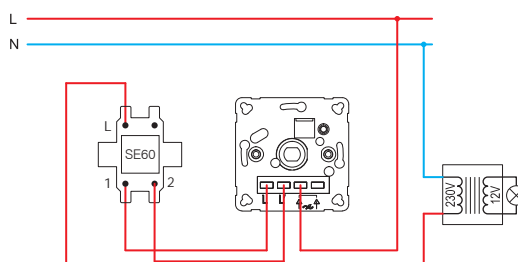

EE16, EE19

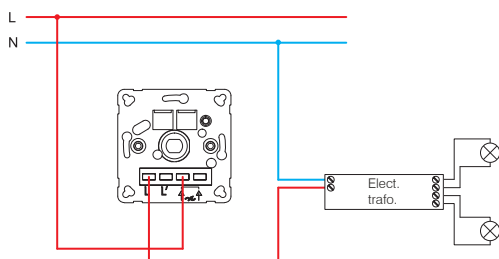

EE16, EE19

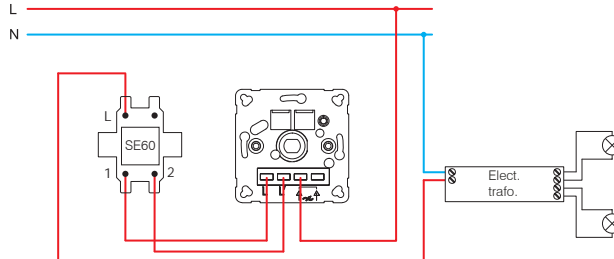

EE17

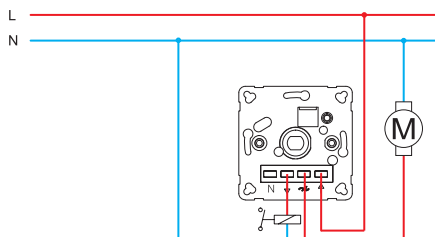

EE15 (40÷400W)

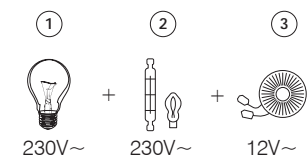

EE16 (20÷400W)

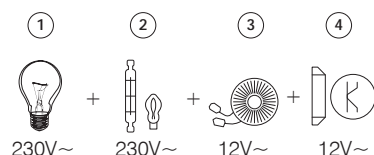

EE19 (GLS 10÷250W ; LED 0÷100W)

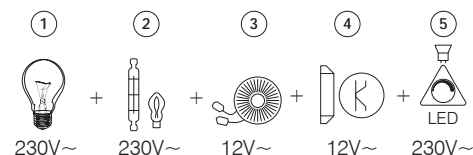

- 1 - žarnica z žarilno nitko / incandescent lamp
- 2 - halogenska žarnica / halogen lamp

- 3 - klasični transformator / classical transformer
- 4 - elektronski transformator / electronic transformer

- 5 - zatemnilna LED sijalka / dimmable LED lamp

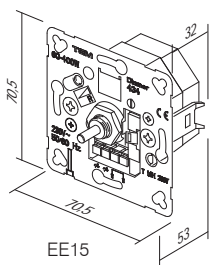

EE15
EE16
EE17
EE19

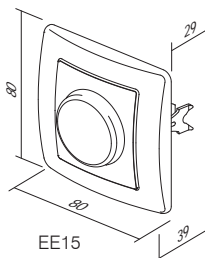

EE15
EE16
EE19

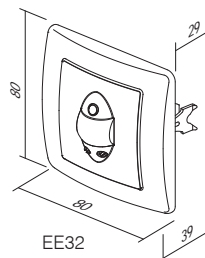

EE32

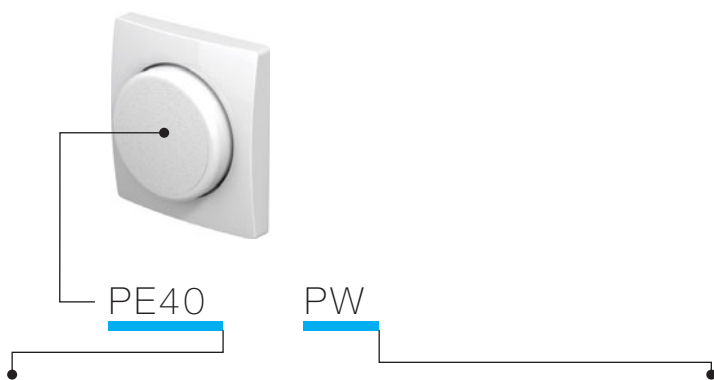

tip type	naziv description	barva colour
PE40	POKROV ZATEMNILNO STIKALO COVER DIMMER	<input type="checkbox"/> PW bela-sijaj <i>polar white</i> <input type="checkbox"/> IW bež-sijaj <i>ivory white</i> <input type="checkbox"/> ES srebrna-mat <i>elox silver</i> <input type="checkbox"/> CO beli duroplast <i>white thermoset</i> <input type="checkbox"/> NB črna-sijaj <i>night black</i>

POKROV ZATEMNILNO STIKALO Ø4



- PE40PW
- PE40IW
- PE40ES
- PE40CO
- PE40NB

- pokrov zatemnilno stikalo Ø4mm
- za EE17

COVER DIMMER Ø4
- cover dimmer Ø4mm
- for EE17



POKROV ZATEMNILNO STIKALO Ø6



- PE41PW
- PE41IW
- PE41ES
- PE41CO
- PE41NB

- pokrov zatemnilno stikalo Ø6mm
- za EE15, EE16, EE19

COVER DIMMER Ø6
- cover dimmer Ø6mm
- for EE15, EE16, EE19

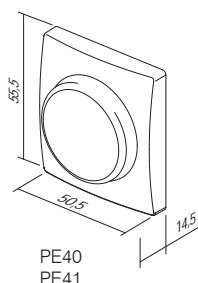

P R I B O R A E

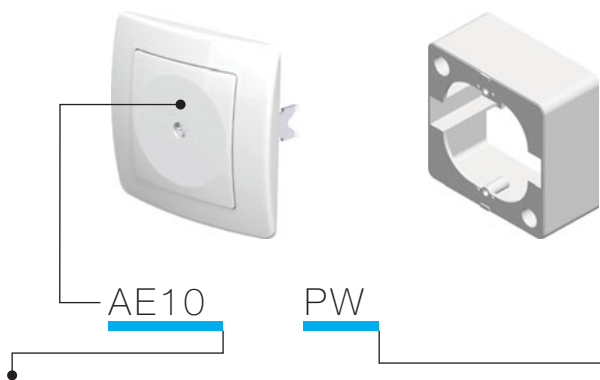

tip type	naziv description	barva colour
AE10	POLNILO BLANK	<input type="checkbox"/> PW bela-sijaj polar white
AE20	PRIKLJUČEK PETPOLNI STALNI 3P+N+E 5X4mm ² CONNECTION BOX 3P+N+E 5X4mm ²	<input type="checkbox"/> IW bež-sijaj ivory white
AE30	OHIŠJE NO 1 SURFACE MOUNT BOX	<input type="checkbox"/> ES srebrna-mat elox silver
.		<input type="checkbox"/> CO beli duroplast white thermoset
.		<input checked="" type="checkbox"/> NB črna-sijaj night black



- AE10PW
- AE10IW
- AE10ES
- AE10CO
- AE10NB

POLNILO

- za pokrivanje praznih odprtih

BLANK

- for filling up empty spaces

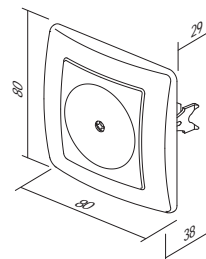

- AE20PW
- AE20IW

PRIKLJUČEK PETPOLNI STALNI 3P+N+E 5x4mm²

- 3P+N+E stalni priključek
- 16A 400V~
- ustreza VDE 0601-1:2000
- vijajčna pritrditev vodnikov 1.5-4mm²

CONNECTION BOX 5POLE 3P+N+E 5x4mm²

- 3P+N+E connection box
- 16A 400V~
- in accordance with VDE 0606-1:2000
- screw contacts 1.5-4mm²

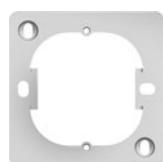
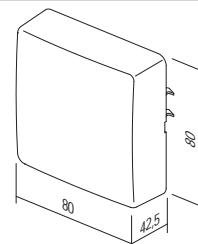

- AE30PW
- AE30IW

OHIŠJE NO 1

- nadometno ohišje

SURFACE MOUNT BOX 1

- surface mounting box

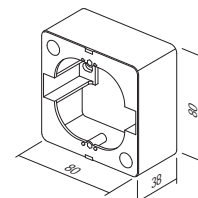

STENSKI ŠČITNIK



- AE50PW
- AE50TS

- ščitnik stene okoli stikala ali vtičnice
WALL PROTECTION
 - protects surface around socket or switch

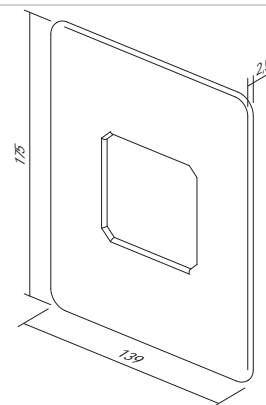

OTROŠKA ZAŠČITA KS



- AE51PW
- AE51W

- KS otroška zaščita pred dotikom kontaktov
CHILD PROTECTION KS
 - KS additional child protection insert - shuttered live contacts

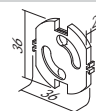

O K V I R J I O E

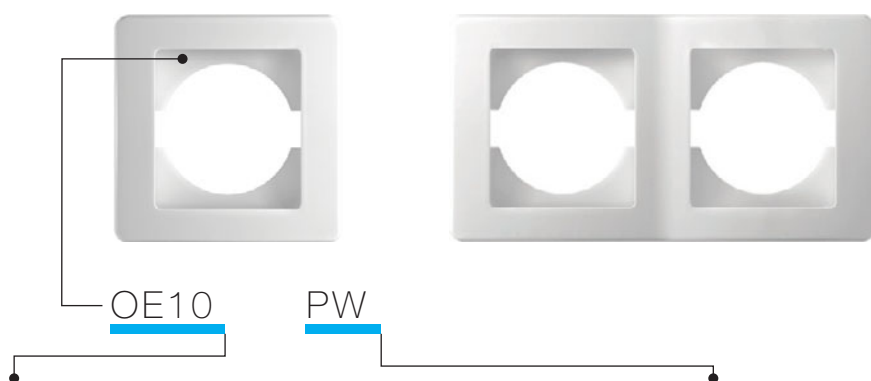

tip type	naziv description	barva colour
OE10	OKVIR EKONOMIK 1 <i>SURROUND EKONOMIK 1</i>	<input type="checkbox"/> PW bela-sijaj <i>polar white</i>
OE20	OKVIR EKONOMIK 2 HORIZONTALNI <i>SURROUND EKONOMIK 2 HORIZONTAL</i>	<input type="checkbox"/> IW bež-sijaj <i>ivory white</i>
OE30	OKVIR EKONOMIK 3 HORIZONTALNI <i>SURROUND EKONOMIK 3 HORIZONTAL</i>	<input type="checkbox"/> ES srebrna-mat <i>elox silver</i>
.		<input type="checkbox"/> CO beli duroplast <i>white thermoset</i>
.		<input type="checkbox"/> NB črna-sijaj <i>night black</i>

OKVIR EKONOMIK 1



- OE10PW
- OE10IW
- OE10ES
- OE10CO
- OE10NB

- dekorativni enojni okvir
- ustreza EN 60669-1

SURROUND EKONOMIK 1

- decorative surround 1-gang
- in accordance with EN 60669-1

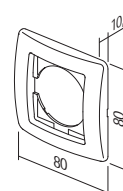

OKVIR EKONOMIK 2 HORIZONTALNI



- OE20PW
- OE20IW
- OE20ES
- OE20CO
- OE20NB

- dekorativni dvojni horizontalni okvir
- ustreza EN 60669-1

SURROUND EKONOMIK 2 HORIZONTAL

- decorative surround 2-gang horizontal
- in accordance with EN 60669-1

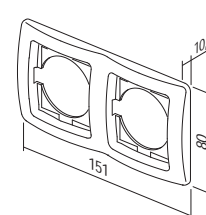

OKVIR EKONOMIK 2 VERTIKALNI



- OE21PW
- OE21IW
- OE21ES
- OE21CO
- OE21NB

- dekorativni dvojni vertikalni okvir
- ustreza EN 60669-1

SURROUND EKONOMIK 2 VERTICAL

- decorative surround 2-gang vertical
- in accordance with EN 60669-1

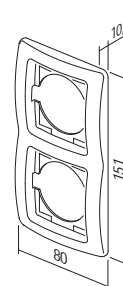

OKVIR EKONOMIK 3 HORIZONTALNI



- OE30PW
- OE30IW
- OE30ES
- OE30CO
- OE30NB

- dekorativni trojni horizontalni okvir
- ustreza EN 60669-1

SURROUND EKONOMIK 3 HORIZONTAL

- decorative surround 3-gang horizontal
- in accordance with EN 60669-1

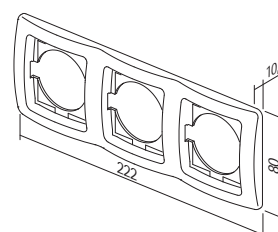

OKVIR EKONOMIK 3 VERTIKALNI



- OE31PW
- OE31IW
- OE31ES
- OE31CO
- OE31NB

- dekorativni trojni vertikalni okvir
- ustreza EN 60669-1

SURROUND EKONOMIK 3 VERTICAL
- decorative surround 3-gang vertical
- in accordance with EN 60669-1

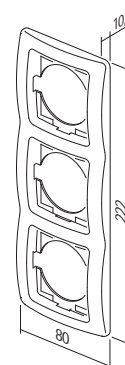

OKVIR EKONOMIK 4 HORIZONTALNI



- OE40PW
- OE40IW
- OE40ES
- OE40NB

- dekorativni četvorni horizontalni okvir
- ustreza EN 60669-1

SURROUND EKONOMIK 4 HORIZONTAL
- decorative surround 4-gang horizontal
- in accordance with EN 60669-1

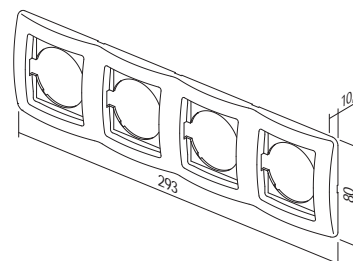

OKVIR EKONOMIK 4 VERTIKALNI



- OE41PW
- OE41IW
- OE41ES
- OE41NB

- dekorativni četvorni vertikalni okvir
- ustreza EN 60669-1

SURROUND EKONOMIK 4 VERTICAL
- decorative surround 4-gang vertical
- in accordance with EN 60669-1

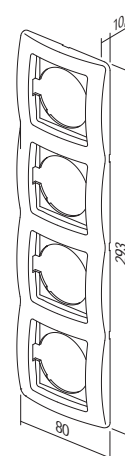

DEKORATIVNI OKVIRČKI COLOR / COLOR DECORATIVE FRAMES



- OE90GR ZELENA / GREEN
- OE90BL MODRA / BLUE
- OE90VO VIJOLA / VIOLET
- OE90PI ROZA / PINK
- OE90RD RDEČA / RED
- OE90YL RUMENA / YELLOW
- OE90WH BELA / WHITE
- OE90GY SIVA / GREY
- OE90BK ČRNA / BLACK
- OE90BR RJAVA / BROWN

- OE90MB MET. MODRA / MET. BLUE
- OE90BZ BRON / BRONZE
- OE90CR SREBRNA / SILVER
- OE90GO ZLATA / GOLD



TEM



KATALOG / CATALOGUE

fontana



STIKALA SF
SWITCHES SF



198

VTIČNICE VF
SOCKETS VF



200

SETI CF
SETS CF



201

PRIBOR AF
ACCESSORIES AF



203



SF10

PW

TI

tip type	naziv description	tehnični opis technical data	barva colour	opcijski opis 1 optional data 1
SF10	STIKALO ENOPOLNO SWITCH 1WAY	IP44 10AX 250V~	<input type="checkbox"/> PW bela white	TI tlivka+indikator neon lamp+indication
SF11	TIPKALO ENOPOLNO PUSH BUTTON 1WAY	IP44 10A 250V~	<input type="checkbox"/> GY siva-mat grey-mat	
SF20	STIKALO DVOPOLNO SWITCH 2POLE	IP44 10AX 250V~		
...

STIKALO ENOPOLNO IP44 10AX 250V~



- SF10PW
- SF10GY

- 10AX 250V~, tip SF10
- ustreza EN 60669-1
- brezvijačna pritrditev vodnikov 1.5-2.5mm²
SWITCH 1WAY IP44 10AX 250V~
- 10AX 250V~, type SF10
- in accordance with EN 60669-1
- plug-in contacts 1.5-2.5mm²

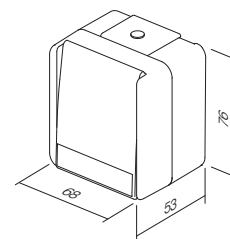

STIKALO ENOPOLNO IP44 10AX 250V~ __ TI



- SF10PWTI
- SF10GYTI

- TI indikator+tlivka
- 10AX 250V~, tip SF10
- ustreza EN 60669-1
- brezvijačna pritrditev vodnikov 1.5-2.5mm²
SWITCH 1WAY IP44 10AX 250V~ __ TI
- TI indicator+neon lamp
- 10AX 250V~, type SF10
- in accordance with EN 60669-1
- plug-in contacts 1.5-2.5mm²

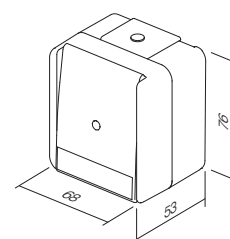

TIPKALO ENOPOLNO IP44 10A 250V~ __ TI



- SF11PWTI
- SF11GYTI

- TI indikator+tlivka
- 10A 250V~, tip SF11
- ustreza EN 60669-1
- brezvijačna pritrditev vodnikov 1.5-2.5mm²
PUSH BUTTON 1WAY IP44 10A 250V~ __ TI
- TI indicator+neon lamp
- 10A 250V~, type SF11
- in accordance with EN 60669-1
- plug-in contacts 1.5-2.5mm²

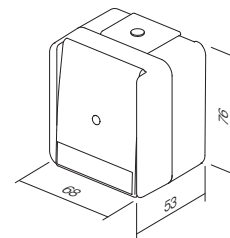

STIKALO DVOPOLNO IP44 10AX 250V~



- SF20PW
- SF20GY

- 10AX 250V~, tip SF20
- ustreza EN 60669-1
- brezvijačna pritrditev vodnikov 1.5-2.5mm²
SWITCH 2POLE IP44 10AX 250V~
- 10AX 250V~, type SF20
- in accordance with EN 60669-1
- plug-in contacts 1.5-2.5mm²

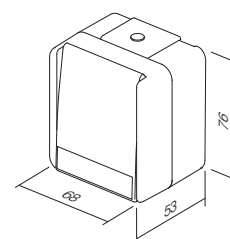

STIKALO SERIJSKO IP44 10AX 250V~



- SF50PW
- SF50GY

- 10AX 250V~, tip SF50
 - ustreza EN 60669-1
 - brezvijačna pritrnitev vodnikov 1.5-2.5mm²
SWITCH 2GANG-1WAY IP44 10AX 250V~
 - 10AX 250V~, type SF50
 - in accordance with EN 60669-1
 - plug-in contacts 1.5-2.5mm²

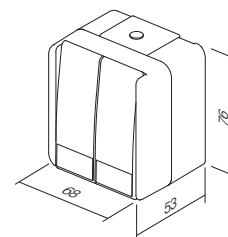

TIPKALO SERIJSKO IP44 10A 250V~



- SF51PW
- SF51GY

- 10A 250V~, tip SF51
 - ustreza EN 60669-1
 - brezvijačna pritrnitev vodnikov 1.5-2.5mm²
PUSH BUTTON 2GANG-1WAY IP44 10A 250V~
 - 10A 250V~, type SF51
 - in accordance with EN 60669-1
 - plug-in contacts 1.5-2.5mm²

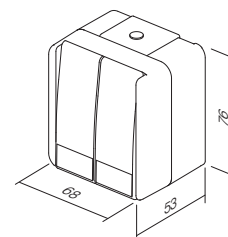

STIKALO MENJALNO IP44 10AX 250V~



- SF60PW
- SF60GY

- 10AX 250V~, tip SF60
 - ustreza EN 60669-1
 - brezvijačna pritrnitev vodnikov 1.5-2.5mm²
SWITCH 2WAY IP44 10AX 250V~
 - 10AX 250V~, type SF60
 - in accordance with EN 60669-1
 - plug-in contacts 1.5-2.5mm²

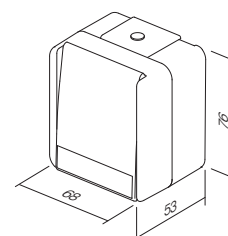

STIKALO MENJALNO IP44 10AX 250V~ __ TI



- SF60PWTI
- SF60GYTI

- TI indikator+tlivka
 - 10AX 250V~, tip SF60
 - ustreza EN 60669-1
 - brezvijačna pritrnitev vodnikov 1.5-2.5mm²
SWITCH 2WAY IP44 10AX 250V~ __ TI
 - TI indicator + neon lamp
 - 10AX 250V~, type SF60
 - in accordance with EN 60669-1
 - plug-in contacts 1.5-2.5mm²

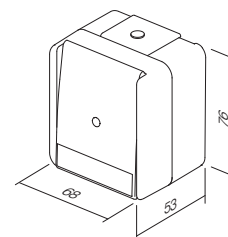

STIKALO DVOJNO MENJALNO IP44 10AX 250V~



- SF63PW
- SF63GY

- 10AX 250V~, tip SF63
 - ustreza EN 60669-1
 - brezvijačna pritrnitev vodnikov 1.5-2.5mm²
SWITCH 2WAY DOUBLE IP44 10AX 250V~
 - 10AX 250V~, type SF63
 - in accordance with EN 60669-1
 - plug-in contacts 1.5-2.5mm²

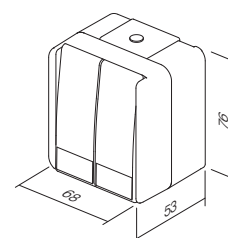

STIKALO KRIŽNO IP44 10AX 250V~



- SF70PW
- SF70GY

- 10AX 250V~, tip SF70
 - ustreza EN 60669-1
 - brezvijačna pritrnitev vodnikov 1.5-2.5mm²
SWITCH INTERMEDIATE IP44 10AX 250V~
 - 10AX 250V~, type SF70
 - in accordance with EN 60669-1
 - plug-in contacts 1.5-2.5mm²

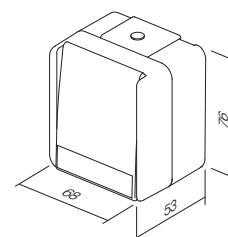

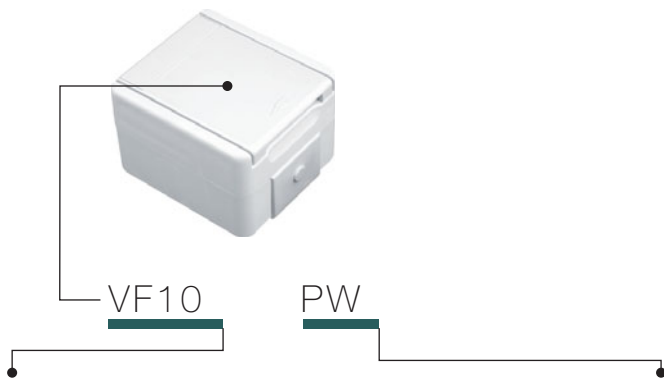

tip type	naziv description	tehnični opis technical data	barva colour
VF10	VTIČNICA SCHUKO+POKROV SOCKET SCHUKO+COVER	IP44 2P+E 16A 250V~	<input type="checkbox"/> PW bela-mat white-mat <input type="checkbox"/> GY siva-mat grey-mat

VTIČNICA SCHUKO+POKROV IP44 2P+E 16A 250V~



- VF10PW
- VF10GY

- vijajčna pritrditev vodnikov 1.5-2.5mm²
- 2P+E schuko+pokrov
- 16A 250V~, tip VF10
- ustreza EN 60884-1, CEE7

SOCKET SCHUKO+COVER IP44 2P+E 16A 250V~

- screw contacts 1.5-2.5mm²
- 2P+E schuko+cover
- 16A 250V~, type VF10
- in accordance with EN 60884-1, CEE7

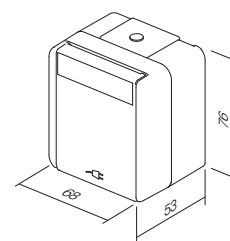

VTIČNICA SCHUKO+POKROV IP44 2P+E 16A 250V~ BV



- VF12PW
- VF12GY

- BV brezvijačna pritrditev vodnikov 1.5-2.5mm²
- 2P+E schuko+pokrov
- 16A 250V~, tip VF12
- ustreza EN 60884-1, CEE7

SOCKET SCHUKO+COVER IP44 2P+E 16A 250V~ BV

- BV plug-in contacts 1.5-2.5mm²
- 2P+E schuko+cover
- 16A 250V~, type VF12
- in accordance with EN 60884-1, CEE7

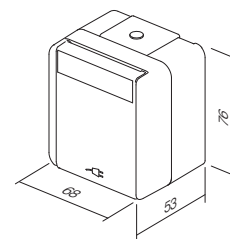

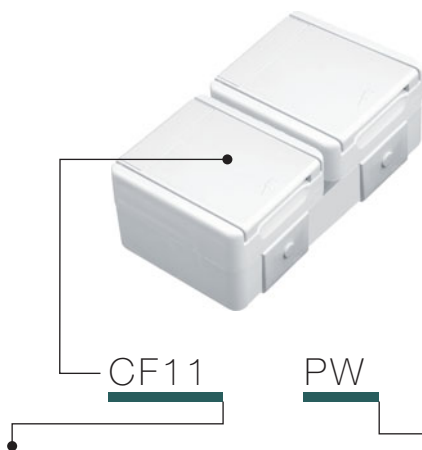

tip type	naziv description	tehnični opis technical data	barva colour
CF10	SET VTIČNICA SCHUKO DVOJNA HORIZ SOCKET SET SCHUKO DOUBLE HORIZ	2x 2P+E 16A 250V~ IP44	<input type="checkbox"/> PW bela-mat white-mat
CF11	SET VTIČNICA SCHUKO DVOJNA VERT SOCKET SET SCHUKO DOUBLE VERT	2x 2P+E 16A 250V~ IP44	<input checked="" type="checkbox"/> GY siva-mat grey-mat
CF12	SET VTIČNICA SCH + STIKALO MEN HORIZ SOCKET SCH+SWITCH 2WAY HORIZ	16A + 10A 250V~ IP44	
.	.	.	.
.	.	.	.

SET VTIČNICA SCHUKO DVOJNI HORIZONTALNI IP44 2x 2P+E 16A 250V~



- CF10PW - vijačna pritrditev vodnikov 1.5-2.5mm²
- 2x 2P+E schuko+pokrov horizontalni
- 16A 250V~, tip CF10
- ustreza EN 60884-1, CEE7
- CF10GY

SOCKET SET SCHUKO DOUBLE HORIZONTAL

IP44 2x 2P+E 16A 250V~
- screw contacts 1.5-2.5mm²
- 2x 2P+E schuko + cover horizontal
- 16A 250V~, type CF10
- in accordance with EN 60884-1, CEE7

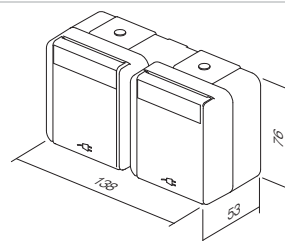

SET VTIČNICA SCHUKO DVOJNI VERTIKALNI IP44 2x 2P+E 16A 250V~



- CF11PW - vijačna pritrditev vodnikov 1.5-2.5mm²
- 2x 2P+E schuko+pokrov vertikalni
- 16A 250V~, tip CF11
- ustreza EN 60884-1, CEE7
- CF11GY

SOCKET SET SCHUKO DOUBLE VERTICAL

IP44 2x 2P+E 16A 250V~
- screw contacts 1.5-2.5mm²
- 2x 2P+E schuko + cover vertical
- 16A 250V~, type CF11
- in accordance with EN 60884-1, CEE7

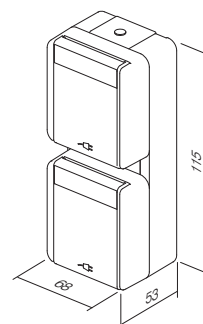

SET VTIČNICA SCH + STIKALO MEN HORIZONTALNI IP44 16A + 10AX 250V~



- CF12PW - vijačna (vtičnica), brezvijačna (stikalo) pritrditev
vodnikov 1.5-2.5mm²
- 2P+E schuko+pokrov + stikalo menjalno horizontalni
- 16A + 10AX 250V~, tip CF12
- ustreza EN 60884-1, CEE7, EN 60669-1
- CF12GY

SOCKET SCH+SWITCH SET 2WAY HORIZONTAL

IP44 16A + 10AX 250V~
- screw (socket), plug-in (switch) contacts 1.5-2.5mm²
- 2P+E schuko + cover + switch 2-way horizontal
- 16A + 10AX 250V~, type CF12
- in accordance with EN 60884-1, CEE7, EN 60669-1

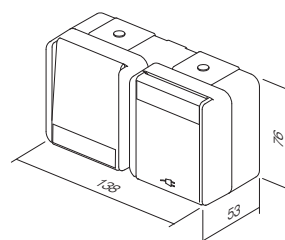

SET VTIČNICA SCH + STIKALO MEN VERTIKALNI IP44 16A + 10AX 250V~



- CF13PW - vijačna (vtičnica), brezvijačna (stikalo)
- CF13GY - pritrditev vodnikov 1.5-2.5mm²
- 2P+E schuko+pokrov + stikalo menjalno vertikalni
- 16A + 10AX 250V~, tip CF13
- ustreza EN 60884-1, CEE7, EN 60669-1

SOCKET SCH+SWITCH 2WAY SET VERTICAL
IP44 16A + 10AX 250V~

- screw (socket), plug-in (switch)
- contacts 1.5-2.5mm²
- 2P+E schuko+cover + switch 2-way vertical
- 16A + 10AX 250V~, type CF13
- in accordance with EN 60884-1, CEE7, EN 60669-1

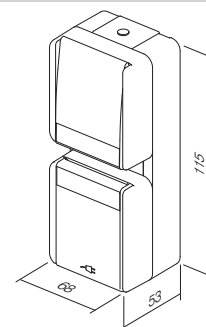

SET VTIČNICA SCHUKO DVOJNI HORIZONTALNI IP44 2x 2P+E 16A 250V~BV



- CF14PW - BV brezvijačna pritrditev vodnikov 1.5-2.5mm²
- CF14GY - 2x 2P+E schuko+pokrov horizontalna
- 16A 250V~, tip CF14
- ustreza EN 60884-1, CEE7

SOCKET SET SCHUKO DOUBLE HORIZONTAL
IP44 2x 2P+E 16A 250V~ BV

- BV plug-in contacts 1.5-2.5mm²
- 2x 2P+E schuko+cover horizontal
- 16A 250V~, type CF14
- in accordance with EN 60884-1, CEE7

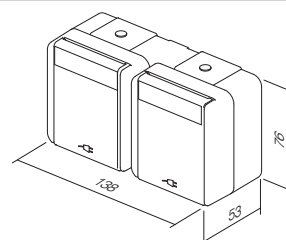

SET VTIČNICA SCHUKO DVOJNI VERTIKALNI IP44 2x 2P+E 16A 250V~ BV



- CF15PW - BV brezvijačna pritrditev vodnikov 1.5-2.5mm²
- CF15GY - 2x 2P+E schuko+pokrov vertikalna
- 16A 250V~, tip CF15
- ustreza EN 60884-1, CEE7

SOCKET SET SCHUKO DOUBLE VERTICAL
IP44 2x 2P+E 16A 250V~ BV

- BV plug-in contacts 1.5-2.5mm²
- 2x 2P+E schuko+cover vertical
- 16A 250V~, type CF15
- in accordance with EN 60884-1, CEE7

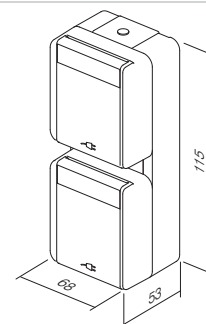

SET VTIČNICA SCH + STIKALO MEN HORIZONTALNI IP44 16A + 10AX 250V~ BV



- CF16PW - BV brezvijačna pritrditev vodnikov 1.5-2.5mm²
- CF16GY - 2P+E schuko+pokrov + stikalo menjalno horizontalni
- 16A + 10AX 250V~, tip CF16
- ustreza EN 60884-1, CEE7, EN 60669-1

SOCKET+SWITCH SET SCH+2WAY HORIZONTAL
IP44 16A + 10AX 250V~ BV

- BV plug-in contacts 1.5-2.5mm²
- 2P+E schuko+cover + switch 2-way horizontal
- 16A + 10AX 250V~, type CF16
- in accordance with EN 60884-1, CEE7, EN 60669-1

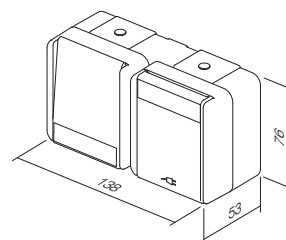

SET VTIČNICA SCH+STIKALO MEN VERTIKALNI IP44 16A + 10AX 250V~ BV



- CF17PW - BV brezvijačna pritrditev vodnikov 1.5-2.5mm²
- CF17GY - 2P+E schuko+pokrov + stikalo menjalno vertikalni
- 16A + 10AX 250V~, tip CF17
- ustreza EN 60884-1, CEE7, EN 60669-1

SOCKET SCH+SWITCH 2WAY SET VERTICAL
IP44 16A + 10AX 250V~ BV

- BV plug-in contacts 1.5-2.5mm²
- 2P+E schuko+cover + switch 2-way vertical
- 16A + 10AX 250V~, type CF17
- in accordance with EN 60884-1, CEE7, EN 60669-1

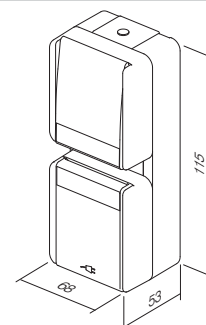

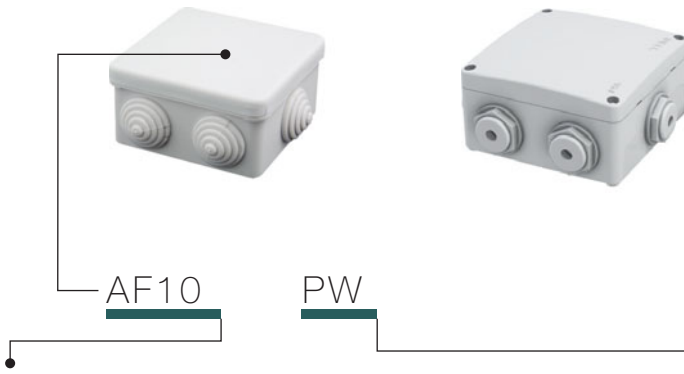

tip type	naziv description	tehnični opis technical data	barva colour
AF10	RAZVODNICA DISTRIBUTION BOX	IP44 RN01	<input type="checkbox"/> PW bela-mat white-mat
AF20	RAZVODNICA DISTRIBUTION BOX	IP55 NDO1	<input type="checkbox"/> GY siva-mat grey-mat

RAZVODNICA IP44 RN01



- AF10PW - nadometna razvodnica IP44
- 16A 400V~
- ustreza EN 60309-1
- AF10GY

DISTRIBUTION BOX IP44 RN01
 - surface mounting distribution box IP44
 - 16A 400V~
 - in accordance with EN 60309-1

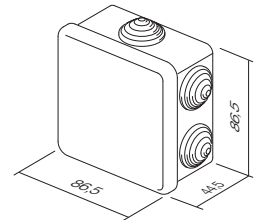

RAZVODNICA IP55 ND01



- AF20PW - nadometna razvodnica IP55
- uvodnice priložene
- ustreza EN 60309-1
- AF20GY

DISTRIBUTION BOX IP55 ND01
 - surface mounting connection box IP55
 - glands included
 - in accordance with EN 60309-1

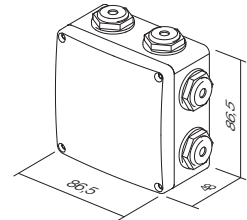

MODUL

šifra	opis izdelka	stran	šifra	opis izdelka	stran
STIKALA SM			KOMUNIKACIJSKI PRIBOR KA		
SM10	STIKALO ENOPOLNO 16AX 250V~ 1M	56	KA10	KONEKTOR KS CAT3 RJ11 6/4	76
SM11	TIPKALO ENOPOLNO 16A 250V~ 1M	56	KA11	KONEKTOR KS CAT5e RJ45 8/8	76
SM12	STIKALO ENOPOLNO 20AX 250V~ 1M	56	KA12	KONEKTOR KS CAT5eS RJ45 8/8	76
SM20	STIKALO DVOPOLNO 16AX 250V~ 1M	56	KA15	KONEKTOR KS CAT6 SCHRACK RJ45 8/8	76
SM40	STIKALO ŽALUZIJSKO 1-0-2 16AX 250V~ 1M	57	KA16	KONEKTOR KS CAT6S SCHRACK RJ45 8/8	76
SM41	TIPKALO ŽALUZIJSKO 1-0-2 16A 250V~ 1M	57	KA17	KONEKTOR KS CAT6a SCHRACK RJ45 8/8	76
SM60	STIKALO MENJALNO 16AX 250V~ 1M	57	KA27	KONEKTOR KS HDMI	77
SM61	TIPKALO MENJALNO 16A 250V~ 1M	57	ELEKTRONIKA EM		
SM70	STIKALO KRIŽNO 16AX 250V~ 1M	57	EM10--	ZATEMNILNIK ROTACIJSKI RL 300W 1M	78
SM10--	STIKALO ENOPOLNO 16AX 250V~ 1M	58	EM11--	ZATEMNILNIK ROT/MENJALNI RL 300W 1M	78
SM10--IN	STIKALO ENOPOLNO 16AX 250V~ 1M IN	58	EM21	ZATEMNILNIK VGRADNI RLC 300W	79
SM11--	TIPKALO ENOPOLNO 16A 250V~ 1M	58	EM22	ZATEMNILNIK VGRADNI R 500W	79
SM11--IN01	TIPKALO ENOPOLNO 16A 250V~ 1M IN 01	58	EM25--	ZATEMNILNIK UNIVEZALNI RLC 0-300W 2M	80
SM11--IN02	TIPKALO ENOPOLNO 16A 250V~ 1M IN 02	59	EM26--	TIPKALO UPRAVLJALNO 2M	82
SM20--NT03	STIKALO DVOPOLNO 16AX 250V~ 1M NT 03	59	EM27	FILTER OMREŽNIH MOTENJ	82
SM20--IN	STIKALO DVOPOLNO 16AX 250V~ 1M IN	59	EM25PPOL20	SET STIKALO / ZATEMNILNIK UNIVERZALNI RLC 0-300W 2M PP OL20	82
SM40--NT10	STIKALO ŽALUZIJSKO 1-0-2 16AX 250V~ 1M NT 10	59	EM31--	IR STIKALO 5A 250V~ 1M	83
SM41--NT10	TIPKALO ŽALUZIJSKO 1-0-2 16A 250V~ 1M NT 10	59	EM32--	IR STIKALO 5A 250V~ 2M	83
SM60--	STIKALO MENJALNO 16AX 250V~ 1M	59	EM37--	TERMOSTAT OSNOVNI 6A 250V~2M	85
SM61--	TIPKALO MENJALNO 16A 250V~ 1M	60	EM40--	KARTIČNO STIKALO OSNOVNO 3A 250V~ 3M	86
SM62--CD	TIPKALO MENJALNO Z VRVICO 16A 250V~ 1M CD	60	EM47	KARTICA ISO ČRTNA KODA	86
SM70--	STIKALO KRIŽNO 16AX 250V~ 1M	60	EM44--	KARTIČNO STIKALO ZA VARČEVANJE Z ENERGIJO 3M	87
TIPKE TM			EM49	RELE ENOTA ZA KARTIČNO STIKALO 2x16A 250V~	87
TM11--	TIPKA 1M	61	EM45	RAZDELILNIK SPL-1	87
TM11--IN	TIPKA 1M IN	61	EM60--	VTIČNICA ZA BRIVNIK 2.5A 230V~/15A 110V~ 3M	88
TM12--	TIPKA 2M	61	EM65--	POLNILNIK USB 5V 1A 2M	88
TM12--IN	TIPKA 2M IN	61	EM55	LED ZASILNA SVETILKA 250V~ 1.5W, NiMH 6h 7M	88
TM13--IL	TIPKA Z NAPISNO PLOŠČICO 2M	62	EM50--	SVETILKA LED ENOBARVNA 250V~ 12W 2M	89
TM15--	TIPKA 1M DVOPOLNA	62	EM51--	SVETILKA LED DVOBARVNA 250V~ 2x6W 2M	89
TM21--	POLNILO 1M	62	EM52--	SVETILKA LED 3D DVOBARVNA 230V~ 2x6W 2M	89
TM22--	POLNILO 2M	62	EM70--	STIKALO NA PRSTNI ODTIS ARX1, 3A/12V 2M	90
TM31--	UVODNICA 1M	62	EM80--	STIKALO BREZDOTIČNO 10A 240V~	91
INDIKACIJA IA			EM81--	STIKALO BREZDOTIČNO UPRAVLJALNO	91
IA10--	TLIVKA 220V~ 0,25W	64	EM90--	BRENČAČ 8VA 220V~ 1M	92
IA20--	SIJALKA LED 220V~ 4W	64	EM91--	BRENČAČ 8VA 12V 1M	92
IA21--	SIJALKA LED 24V AC/DC 0,5W	64	EM92--	ZVONEC 8VA 220V~ 1M	92
IA22--	SIJALKA LED 12V AC/DC 0,25W	64	EM93--	ZVONEC 8VA 12V 1M	92
VTIČNICE VM			EM95--	REGULATOR GLASNOSTI ZA 100V AVDIO LINIJO 35W 2M	93
VM10--	VTIČNICA SCHUKO+KS 2P+E 16A 250V~ 2M	66	EM96--	REGULATOR GLASNOSTI NIZKOOHMSKI 4-8 Ω 35W 2M	93
VM11--	VTIČNICA SCHUKO+KS+POKROV 2P+E 16A 250V~ 2M	66	SETI CM		
VM20--	VTIČNICA EURO+KS 2P 10A 250V~ 1M	67	CM10--	SET VTIČNIC 2x SCHUKO 2P+E 16A 250V~ 4M	94
VM40--	VTIČNICA FRANCOŠKA+KS 2P+E 16A 250V~ 2M	67	CM11--	SET VTIČNIC 3x SCHUKO 2P+E 16A 250V~ 7M	94
VM41--	VTIČNICA FRANCOŠKA+KS+POKROV 2P+E 16A 250V~ 2M	67	CM15	SET VEZNIKOV BARVNI 3x1,5mm2 1M	95
VM30--	VTIČNICA ITALIJANSKA P17/11+KS 2P+E 16A 250V~ 1M	67	CM16	SET VEZNIKOV BARVNI 3x2,5mm2 2M	95
VM31--	VTIČNICA SCHUKO/ITA P17/11+KS 2P+E 16A 250V~ 2M	67	CM17	SET VIJAKOV 3,5x20	95
VM32--	VTIČNICA SCHUKO/ITA P30+KS 2P+E 16A 250V~ 2M	68	CM18	SET VIJAKOV 3,5x35	95
VM33--	VTIČNICA ITALIJANSKA P11+KS 2P+E 10A 250V~ 1M	68	CM19	SET VIJAKOV 3,5x50	95
VM21--	VTIČNICA EURO/AMERIŠKA+KS 2P 16A 250V~ 1M	68	CM22--	SET ZA STIKALA IP44 2M	95
VM51--	VTIČNICA BRITANSKA BS546+KS 2P+E 15A 250V~ 2M	68	CM23--	SET ZA VTIČNICE IP44 2M	95
VM52--	VTIČNICA BRITANSKA BS 1363+KS 2P+E 13A 250V~ 2M	68	CM25--OL	SET KOPALNIŠKI 3x20AX 250V~ 4M OL	95
VM80	PRENAPETOSTNA ZAŠČITA MPE MINI 275V/50Hz	68	CM25--OS	SET KOPALNIŠKI 3x20AX 250V~ 4M OS	95
KOMUNIKACIJE KM			NM41	NOSILEC KOPALNIŠKI SET 4M	96
KM10--	VTIČNICA TV OSNOVNA 0dB 1M	70	OL41--	OKVIR LINE KOPALNIŠKI SET	96
KM20--	VTIČNICA TV OSNOVNA 0dB 2M	70	OS41--	OKVIR SOFT KOPALNIŠKI SET	96
KM11--	VTIČNICA TV KONČNA 1dB 1M	70	ANTIBAKTERIJSKI PROGRAM AW		
KM12--	VTIČNICA TV PREHODNA 10dB 1M	70	TM11AW	TIPKA 1M	99
KM15--	VTIČNICA SAT OSNOVNA 0dB 1M	71	TM11AWIN	TIPKA 1M IN	99
KM24--	VTIČNICA SAT OSNOVNA 0dB 2M	71	TM12AW	TIPKA 2M	99
KM16--	VTIČNICA SAT KONČNA 1dB 1M	71	TM12AWIN	TIPKA 2M IN	99
KM19--	VTIČNICA R OSNOVNA 0dB 1M	71	TM21AW	POLNILO 1M	99
KM29--	VTIČNICA R OSNOVNA 0dB 2M	71	TM22AW	POLNILO 2M	99
KM25--	VTIČNICA SAT-TV KONČNA 1dB 2M	71	VM10AW	VTIČNICA SCHUKO+KS 2P+E 16A 250V~ 2M	100
KM22--	VTIČNICA AVDIO 2xRCA 1M	72	VM11AW	VTIČNICA SCHUKO+KS+POKROV 2P+E 16A 250V~ 2M	100
KM23--	VTIČNICA AVDIO ZVOČNIŠKA 1M	72	VM20AW	VTIČNICA EURO+KS 2P 10A 250V~ 1M	100
KM26--	VTIČNICA AVDIO ZVOČNIŠKA 2M	72	KM11AW	VTIČNICA TV KONČNA 1dB 1M	100
KM30--	VTIČNICA TEL LT RJ11 8/4 1M	73	KM35AW	ADAPTER KS 1M	100
KM31--	VTIČNICA TEL BT SEC 6/6 1M	73	OS20AW	OKVIR SOFT 2M	101
KM36--	VTIČNICA TEL KS RJ11 6/4 1M	73	OS24AW	OKVIR SOFT 2x2M	101
KM37--	VTIČNICA CAT5e KS RJ45 8/8 1M	73	OS26AW	OKVIR SOFT 3x2M	101
KM35--	ADAPTER KS 1M	73	OS30AW	OKVIR SOFT 3M	101
KM38--	ADAPTER KS S PRAŠNO ZAŠČITO 1M	73	OS40AW	OKVIR SOFT 4M	101
KM50--	ADAPTER KS UNIVERZALNI 1M	74	OS70AW	OKVIR SOFT 7M	101
KM40--	ADAPTER PD 1M	74	OKVIRJI PURE OP		
KM43--	ADAPTER PD S PRAŠNO ZAŠČITO 1M	74	OP20--	OKVIR PURE 2M	104
KM46--	ADAPTER R&M 1M	74	OP24--	OKVIR PURE 2x2M	104
KM47--	ADAPTER R&M S PRAŠNO ZAŠČITO 1M	74	OP26--	OKVIR PURE 3x2M	104
KM45--	ADAPTER LK 1M	74	OP30--	OKVIR PURE 3M	105
KA26	ADAPTER NEXSANS 2M	75	OP40--	OKVIR PURE 4M	105
KM48--	ADAPTER AT&T SYSTIMAX S PRAŠNO ZAŠČITO 1M	75	OP70--	OKVIR PURE 7M	105
KM51--	VTIČNICA USB TIP A 1M	75	OP13--	OKVIR PURE 1/3M	105
			OP23--	OKVIR PURE 2/3M	105

I N D E X

šifra	opis izdelka	stran
OKVIRJI LINE OL		
OL20--	OKVIR LINE 2M	108
OL24--	OKVIR LINE 2x2M	108
OL26--	OKVIR LINE 3x2M	108
OL28--	OKVIR LINE 4x2M	108
OL30--	OKVIR LINE 3M	109
OL40--	OKVIR LINE 4M	109
OL70--	OKVIR LINE 7M	109
OL10--	OKVIR LINE 1M	109
OL13--	OKVIR LINE 1/3M	109
OL23--	OKVIR LINE 2/3M	109

OKVIRJI SOFT OS		
OS20--	OKVIR SOFT 2M	112
OS24--	OKVIR SOFT 2x2M	112
OS26--	OKVIR SOFT 3x2M	112
OS28--	OKVIR SOFT 4x2M	112
OS30--	OKVIR SOFT 3M	113
OS40--	OKVIR SOFT 4M	113
OS70--	OKVIR SOFT 7M	113
OS72--	OKVIR SOFT 2x7M	113
OS10--	OKVIR SOFT 1M	113
OS13--	OKVIR SOFT 1/3M	113
OS23--	OKVIR SOFT 2/3M	113

NOSILCI NM		
NM20	NOSILEC S KREPELJCI 2M	118
NM21	NOSILEC BREZ VIJAKOV 2M	118
NM24	NOSILEC KOVINSKI S KREPELJCI 2M	118
NM25	NOSILEC KOVINSKI BREZ VIJAKOV 2M	118
NM30	NOSILEC Z VIJAKI 3M	119
NM40	NOSILEC Z VIJAKI 4M	119
NM70	NOSILEC Z VIJAKI 7M	119
NM72	NOSILEC Z VIJAKI 2x7M	119
NM10	NOSILEC S KREPELJCI 1M	120
NM11	NOSILEC BREZ VIJAKOV 1M	120
NM23	NOSILEC S KREPELJCI 2/3M	120
NM32	NOSILEC Z VIJAKI 2/3M	120

D O Z E

šifra	opis izdelka	stran
OKROGLE DOZE		
DE10	DOZA OKROGLA PLITKA ZA ZID SM60-01	124
DE11	DOZA OKROGLA GLOBOKA ZA ZID SM60-06	124
DE30	VEZNI ČLEN DOZE ZA ZID SM60-03	124
DE31	VEZNI ČLEN DOZE ZA ZID SM60-04	124
DE12	DOZA OKROGLA ZA ZID 65-46	125
DE13	DOZA OKROGLA ZA ZID 65-60	125
DE14	PODALJŠEK DOZE ZA ZID 65-46	125
DE32	VEZNI ČLEN DOZE ZA ZID 65-71	125
DE33	VEZNI ČLEN DOZE ZA ZID 65-91	125
DE20	POKROV DOZE ZAŠČITNI 60	125
DE21	POKROV DOZE ZAŠČITNI 65	125
DE22	POKROV DOZE DEKORATIVNI SM60	125
HE10	DOZA OKROGLA ZA VOTLE STENE SM68x40	128
HE11	DOZA OKROGLA ZA VOTLE STENE SM68x55	128
BE10	DOZA OKROGLA ZA BETON 60-49	128
BE11	DOZA OKROGLA ZA BETON 60-77	128
BE20	NOSILEC DOZE ZA BETON	128
BE21	UVODNICA DOZE ZA BETON 16	128

PRAVOKOTNE DOZE		
DM30	DOZA PRAVOKOTNA ZA ZID PM3	132
DM31	DOZA PRAVOKOTNA ZA ZID PM3-65	132
DM40	DOZA PRAVOKOTNA ZA ZID PM4	132
DM41	DOZA PRAVOKOTNA ZA ZID PM4-65	132
DM70	DOZA PRAVOKOTNA ZA ZID PM7	133
DM71	DOZA PRAVOKOTNA ZA ZID PM7-65	133
DM72	DOZA PRAVOKOTNA ZA ZID PM72-65	133
DM80	VEZNI ČLEN DOZE PM	133
DM33	POKROV DOZE ZAŠČITNI PM3	134
DM34	POKROV DOZE DEKORATIVNI PM3	134
DM43	POKROV DOZE ZAŠČITNI PM4	134
DM44	POKROV DOZE DEKORATIVNI PM4	134
DM73	POKROV DOZE ZAŠČITNI PM7	134
DM74	POKROV DOZE DEKORATIVNI PM7	134
DM75	POKROV DOZE DEKORATIVNI PM72	135
HM30	DOZA PRAVOKOTNA ZA VOTLE STENE VM3	136
HM40	DOZA PRAVOKOTNA ZA VOTLE STENE VM4	136
HM70	DOZA PRAVOKOTNA ZA VOTLE STENE VM7	136
HM72	DOZA PRAVOKOTNA ZA VOTLE STENE VM72	136
BM30	DOZA PRAVOKOTNA ZA BETON BM3	137
BM40	DOZA PRAVOKOTNA ZA BETON BM4	137
BM70	DOZA PRAVOKOTNA ZA BETON BM7	137
BM80	PRITRDLJNI ČLEN ZA DOZE BM	137
BM82	DISTANČNI PROFIL ZA DOZE	137

šifra	opis izdelka	stran
RAZVODNE DOZE		
DW10	RAZVODNA DOZA OKROGLA ZA ZID DSM78	140
HW10	RAZVODNA DOZA OKROGLA ZA VOTLE STENE SM78x45	140
DE23	POKROV DOZE DEKORATIVNI SM78	140
DE24	POKROV DOZE ZAŠČITNI 78	140
HW20	RAZVODNA DOZA KVADRATNA ZA ZID SM105x105	140

PRIBOR ZA OŽIČENJE		
UW10--	SPONKA ENOREDNA PA 2x2.5mm2 12P	142
UW11--	SPONKA ENOREDNA PA 2x4mm2 12P	142
UW12--	SPONKA ENOREDNA PA 2x6mm2 12P	142
UW15--	SPONKA ENOREDNAZAPRTA PC 2x2.5mm2 10P	142
UW16--	SPONKA ENOREDNA ZAPRTA PC 2x4mm2 10P	142
UW17--	SPONKA ENOREDNA ZAPRTA PC 2x6mm2 10P	142
UW20--	SPONKA DVOREDNA PA 1.5mm2 12P	142
UW21--	SPONKA DVOREDNA PA 2.5mm2 12P	142
UW22--	SPONKA DVOREDNA PA 4-6mm2 12P	142
UW23--	SPONKA DVOREDNA PA 10mm2 12P	142
UW40--	SPONKA BREZVIJAČNA PA 1.5mm2 3P	143
UW41--	SPONKA BREZVIJAČNA PA 1.5mm2 5P	143
UW42--	SPONKA BREZVIJAČNA PA 1.5mm2 8P	143
UW45--	SPONKA BREZVIJAČNA PA 2.5mm2 3P	143
UW46--	SPONKA BREZVIJAČNA PA 2.5mm2 4P	143
UW47--	SPONKA BREZVIJAČNA PA 2.5mm2 5P	143
UW50--	SPONKA BREZVIJAČNA PA 2.5mm2 2/1P	143

distribucija

šifra	opis izdelka	stran
OHIŠJA CUBO IP20 AC		
AC11--	OHIŠJE NO CUBO Z DNOM IP20 1M	146
AC21--	OHIŠJE NO CUBO Z DNOM IP20 2M	146
AC41--	OHIŠJE NO CUBO Z DNOM IP20 4M	146
AC61--	OHIŠJE NO CUBO Z DNOM IP20 6M	146
OHIŠJA CUBO IP55 AQ		
AQ20--	OHIŠJE NO CUBO IP55 2M	147
AQ22--	OHIŠJE NO CUBO IP55 2x2M	147
AQ30--	OHIŠJE NO CUBO IP55 3M	147
AQ31--	OHIŠJE PO CUBO IP55 3M	147

PARAPETNI KANALI ALUMINIJSKI MA		
RT10	ADAPTER MA 92	148
RT12--	OKVIR MA 92 2/3M	148
RT14--	OKVIR MA 92 4M	148
RT17--	OKVIR MA 92 7M	148
RT20--	OSNOVA KANALA MA 130x65	149
RT21--	OSNOVA KANALA MA 165x65	149
RT25--	POKROV KANALA MA 92	149
RT30	PREGRAĐA MA 43	149
RT31	PREGRAĐA AL. MA 43	149
RT32	PREGRAĐA AL. MA DVOJNA 43	149
RT35--	KONČNI ELEMENT MA 130x65	150
RT36--	KONČNI ELEMENT MA 165x65	150
RT38	RAVNI VEZNI ELEMENT MA 65	150
RT40--	UNIVERZALNI KOT MA 130x65	150
RT41--	UNIVERZALNI KOT MA 165x65	150
RT42	OZEMLJITVENA SPONKA MA 2x A6.3	150
RT43--	L KOTNI ELEMENT MA 130x65	151
RT44--	L KOTNI ELEMENT MA 165x65	151
RT45--	T KOS MA 130x65	151
RT46--	T KOS MA 165x65	151
RT50--	NOSILEC STEBRIČKA MA ENOJNI 130x65	152
RT51--	NOSILEC STEBRIČKA MA DVOJNI 2x 130x65	152
RT52--	STEBRIČEK MA 130x65x500	152
RT53--	STEBRIČEK MA DVOJNI 2x 130x65x500	152
TALNE DOZE MT		
RB30	TALNA DOZA MT 7 H=53mm	154
RB40	TALNA DOZA MT 7 H=88mm	154
RB31	PODSTAVEK TALNE DOZE MT 7 H=53mm	154
RB41	PODSTAVEK TALNE DOZE MT 7 H=88mm	154
RB33	TALNA DOZA MT 14 H=53mm	154
RB43	TALNA DOZA MT 14 H=88mm	154
RB34	PODSTAVEK TALNE DOZE MT 14 H=53mm	155
RB44	PODSTAVEK TALNE DOZE MT 14 H=88mm	155
RB36	TALNA DOZA MT 21 H=53mm	155
RB46	TALNA DOZA MT 21 H=88mm	155
RB37	PODSTAVEK TALNE DOZE MT 21 H=53mm	155
RB47	PODSTAVEK TALNE DOZE MT 21 H=88mm	155
RAZVODNE OMARICE MO		
RB10	ADAPTER ZA DIN LETEV 35mm 1M	156
RB11	ADAPTER ZA DIN LETEV 35mm 2M	156
RB20	RAZVODNA OMARICA MO 12+2	157
RB21	RAZVODNA OMARICA MO 24+4	157
RB22	RAZVODNA OMARICA MO 36+6	157
RB23	RAZVODNA OMARICA MO 48+8	157

ekonomik —

šifra	opis izdelka	stran
STIKALA SE		
SE10	STIKALO ENOPOLNO 10AX 250V ~	170
SE11	TIPKALO ENOPOLNO 10A 250V ~	170
SE22	STIKALO DVOPOLNO 16AX 250V ~	170
SE50	STIKALO SERIJSKO 10AX 250V ~	170
SE51	TIPKALO SERIJSKO 10A 250V ~	171
SE52	STIKALO ŽALUZIJSKO 10AX 250V ~	171
SE53	TIPKALO ŽALUZIJSKO 10A 250V ~	171
SE60	STIKALO MENJALNO 10AX 250V ~	171
SE63	STIKALO DVOJNO MENJALNO 10AX 250V ~	171
SE70	STIKALO KRIŽNO 10AX 250V ~	171
SE10--	STIKALO ENOPOLNO 10AX 250V ~	172
SE10--IN	STIKALO ENOPOLNO 10AX 250V ~ IN	172
SE11--	TIPKALO ENOPOLNO 10A 250V ~	172
SE11--TI50	TIPKALO ENOPOLNO 10A 250V ~ TI 50	172
SE11--TI51	TIPKALO ENOPOLNO 10A 250V ~ TI 51	172
SE11--IL	TIPKALO ENOPOLNO 10A 250V ~ IL	172
SE22--NT03	STIKALO DVOPOLNO 10AX 250V ~ NT 03	172
SE50--	STIKALO SERIJSKO 10AX 250V ~	173
SE51--	TIPKALO SERIJSKO 10A 250V ~	173
SE52--NT09	STIKALO ŽALUZIJSKO 10AX 250V ~ NT 09	173
SE53--NT09	TIPKALO ŽALUZIJSKO 10A 250V ~ NT 09	173
SE60--	STIKALO MENJALNO 10AX 250V ~	173
SE63--	STIKALO DVOJNO MENJALNO 10AX 250V ~	173
SE70--	STIKALO KRIŽNO 10AX 250V ~	173
TIPKE TE		
TE10--	TIPKA NAVADNA	174
TE10--IN	TIPKA NAVADNA IN	174
TE13--IL	TIPKA Z NAPISNO PLOŠČICO IL	174
TE11--	TIPKA SERIJSKA	174
INDIKACIJA I68		
IA10--	TLIVKA 220V ~ 0,25W	175
IA20--	SIJALKA LED 220V ~ 4W	175
IA21--	SIJALKA LED 24V AC/DC 0,5W	175
IA22--	SIJALKA LED 12V AC/DC 0,25W	175
VTIČNICE VE		
VE10--XO	VTIČNICA SCHUKO 2P+E 16A 250V~ XO	178
VE11--XO	VTIČNICA SCHUKO+POKROV 2P+E 16A 250V~ XO	178
VE12--XO	VTIČNICA SCHUKO 2P+E 16A 250V~ BV XO	178
VE13--XO	VTIČNICA SCHUKO+POKROV 2P+E 16A 250V~ BV XO	178
VE10--	VTIČNICA SCHUKO 2P+E 16A 250V~	178
VE11--	VTIČNICA SCHUKO+POKROV 2P+E 16A 250V~	178
VE12--	VTIČNICA SCHUKO 2P+E 16A 250V~ BV	178
VE13--	VTIČNICA SCHUKO+POKROV 2P+E 16A 250V~ BV	178
VE40--XO	VTIČNICA FRANCOSKA 2P+E 16A 250V~ XO	179
VE41--XO	VTIČNICA FRANCOSKA+POKROV 2P+E 16A 250V~ XO	179
VE42--XO	VTIČNICA FRANCOSKA 2P+E 16A 250V~ BV XO	179
VE43--XO	VTIČNICA FRANCOSKA+POKROV 2P+E 16A 250V~ BV XO	179
VE40--	VTIČNICA FRANCOSKA 2P+E 16A 250V~	179
VE41--	VTIČNICA FRANCOSKA+POKROV 2P+E 16A 250V~	179
VE42--	VTIČNICA FRANCOSKA 2P+E 16A 250V~ BV	179
VE43--	VTIČNICA FRANCOSKA+POKROV 2P+E 16A 250V~ BV	179
VE16--	VTIČNICA SCHUKO DVOJNA 2P+E 16A 250V~	180
VE46--	VTIČNICA FRANCOSKA DVOJNA 2P+E 16A 250V~	180
VE30--	VTIČNICA 2P 16A 250V~	180
KOMUNIKACIJE KE		
KE11	VTIČNICA TV-R KONČNA 2dB	181
KE12	VTIČNICA TV-R PREHODNA 8,5dB	181
KE16	VTIČNICA SAT-TV-R KONČNA 3dB	181
KE36	VTIČNICA TEL KS RJ11 6/4	181
KE37	VTIČNICA CAT5e KS RJ45 8/8	182
KE38	VTIČNICA TEL KS DVOJNA 2x RJ11 6/4	182
KE39	VTIČNICA CAT5e KS DVOJNA 2x RJ45 8/8	182
KE45	ADAPTER KS	182
KE46	ADAPTER KS DVOJNI	182
KE47	ADAPTER PD DVOJNI	182
KE10--	VTIČNICA TV OSNOVNA 0dB	183
KE11--	VTIČNICA TV-R KONČNA 2dB	183
KE12--	VTIČNICA TV-R PREHODNA 8,5dB	183
KE16--	VTIČNICA SAT-TV-R KONČNA 3dB	183
KE22--	VTIČNICA AVDIO 2xRCA	183
KE23--	VTIČNICA AVDIO ZVOČNIŠKA	183
KE36--	VTIČNICA TEL KS RJ11 6/4	184
KE37--	VTIČNICA CAT5e KS RJ45 8/8	184
KE38--	VTIČNICA TEL KS DVOJNA 2x RJ11 6/4	184
KE39--	VTIČNICA CAT5e KS DVOJNA 2x RJ45 8/8	184
KE35--	VTIČNICA TEL LT RJ11 6/4	184
POKROVI PA		
PE10--	POKROV TV-R 2P/3P	185
PE20--	POKROV KS ENOJNI	185
PE21--	POKROV KS/PD DVOJNI	185
PE30--	POKROV TAE/TDO	185

šifra	opis izdelka	stran
ELEKTRONIKA EE		
EE15	ZATEMNILNIK ROTACIJSKI MEN RL 400W	186
EE16	ZATEMNILNIK ROTACIJSKI MEN RLC 400W	186
EE17	ZATEMNILNIK ROTACIJSKI FAN 600VA	187
EE19	ZATEMNILNIK ROTACIJSKI MEN LED 100W	187
EE15--	ZATEMNILNIK ROTACIJSKI MEN RL 400W	187
EE16--	ZATEMNILNIK ROTACIJSKI MEN RLC 400W	187
EE19--	ZATEMNILNIK ROTACIJSKI MEN LED 100W	188
EE32--	IR STIKALO 5A 250V ~	188
POKROVI ELEKTRONIKE PE		
PE40--	POKROV ZATEMNILNO STIKALO Ø4	190
PE41--	POKROV ZATEMNILNO STIKALO Ø6	190
PRIBOR AE		
AE10--	POLNILO	191
AE20--	PRIKLJUČEK PETPOLNI STALNI 3P+N+E 5x4mm2	191
AE30--	OHIŠJE NO 1	191
AE50--	ŠČITNIK STENSKI	192
AE51--	ŠČITNIK VTIČNICE OTROŠKI	192
OKVIRJI OE		
OE10--	OKVIR EKONOMIK 1	193
OE20--	OKVIR EKONOMIK 2 HORIZONTALNI	193
OE21--	OKVIR EKONOMIK 2 VERTIKALNI	193
OE30--	OKVIR EKONOMIK 3 HORIZONTALNI	193
OE31--	OKVIR EKONOMIK 3 VERTIKALNI	194
OE40--	OKVIR EKONOMIK 4 HORIZONTALNI	194
OE41--	OKVIR EKONOMIK 4 VERTIKALNI	194
OE90--	OKVIRČEK EKONOMIK DEKORATIVNI	194

fontana —

šifra	opis izdelka	stran
STIKALA SF		
SF10--	STIKALO ENOPOLNO IP44 10A 250V~	198
SF10--TI	STIKALO ENOPOLNO IP44 10A 250V~ TI	198
SF11--TI	TIPKALO ENOPOLNO IP44 10A 250V~ TI	198
SF20--	STIKALO DVOPOLNO IP44 10A 250V~	199
SF50--	STIKALO SERIJSKO IP44 10A 250V~	199
SF51--	TIPKALO SERIJSKO IP44 10A 250V~	199
SF60--	STIKALO MENJALNO IP44 10A 250V~	199
SF60--TI	STIKALO MENJALNO IP44 10A 250V~ TI	199
SF63--	STIKALO DVOJNO MENJALNO IP44 10A 250V~	199
SF70--	STIKALO KRIŽNO IP44 10A 250V~	199
VTIČNICE VF		
VF10--	VTIČNICA SCHUKO+POKROV IP44 2P+E 16A 250V~	200
VF12--	VTIČNICA SCHUKO+POKROV IP44 2P+E 16A 250V~ BV	200
SETI CF		
CF10--	SET VTIČNICA SCHUKO DVOJNA HORIZ IP44 2x2P+E 16A 250V~	201
CF11--	SET VTIČNICA SCHUKO DVOJNA VERT IP44 2x2P+E 16A 250V~	201
CF12--	SET VTIČNICA SCH + STIKALO MEN HOR IP44 16A + 10AX 250V~	201
CF13--	SET VTIČNICA SCH + STIKALO MEN VERT IP44 16A + 10AX 250V~	202
CF14--	SET VTIČNICA SCHUKO DVOJNI HOR IP44 2x 2P+E 16A 250V~BV	202
CF15--	SET VTIČNICA SCHUKO DVOJNI VERT IP44 2x 2P+E 16A 250V~BV	202
CF16--	SET VTIČNICA SCH + STIKALO MEN HOR IP44 16A + 10AX 250V~ BV	202
CF17--	SET VTIČNICA SCH + STIKALO MEN VERT IP44 16A + 10AX 250V~ BV	202
PRIBOR AF		
AF10--	RAZVODNICA IP44 RN01	203
AF20--	RAZVODNICA IP55 ND01	203

I N D E X





MODUL

— funkcijski elementi
function elements



54

dizajn
design

PURE
~~line~~
soft



102

doze
boxes



122

distribucija
distribution



144

ekonomik —



168

fontana —



196



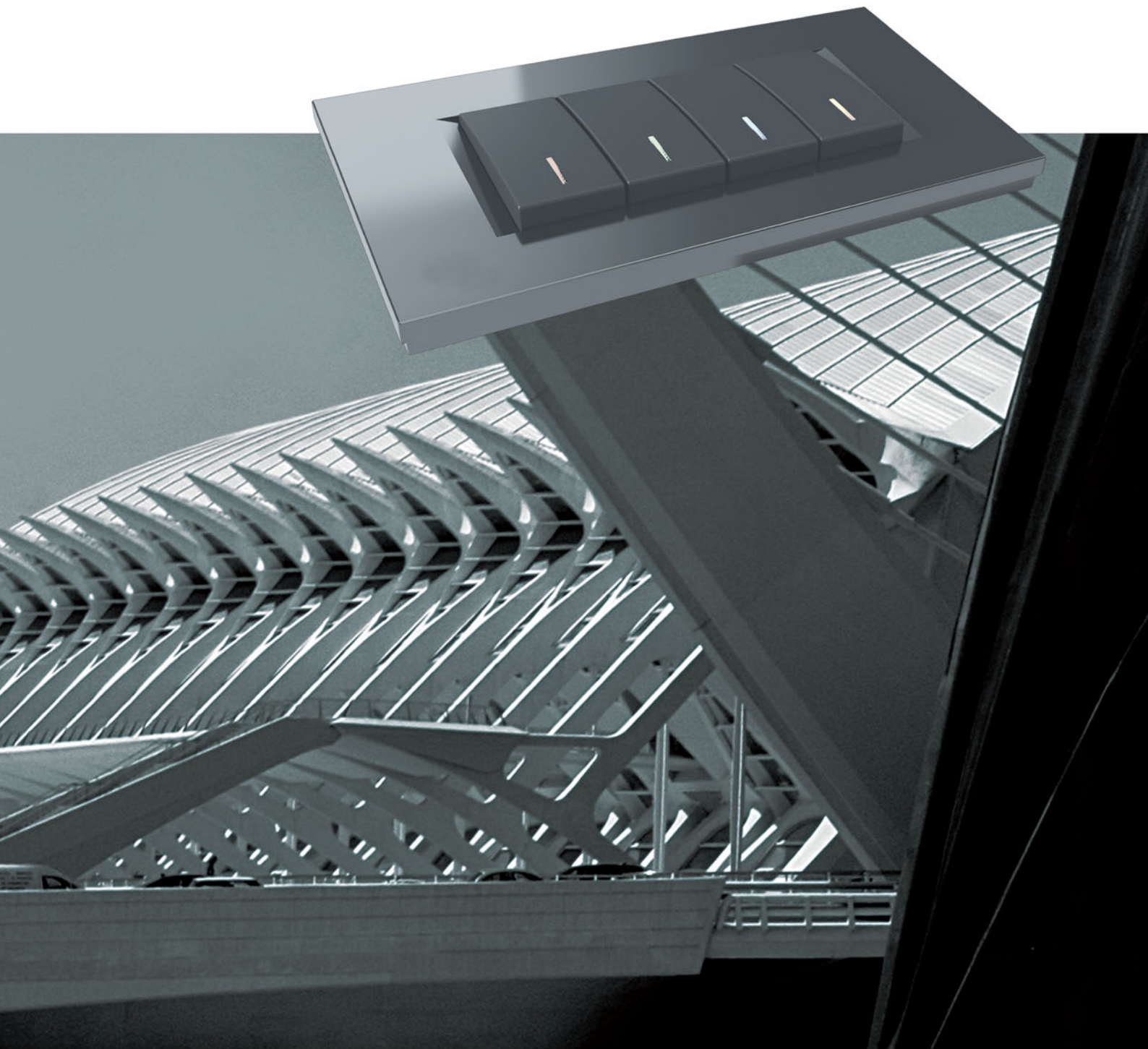

TEM

TEM ČATEŽ d.d.
Čatež 13, 8212 VELIKA LOKA
SLOVENIJA

tem@tem.si
www.tem.si

T +386(0)7 348 99 00
F +386(0)7 348 99 99

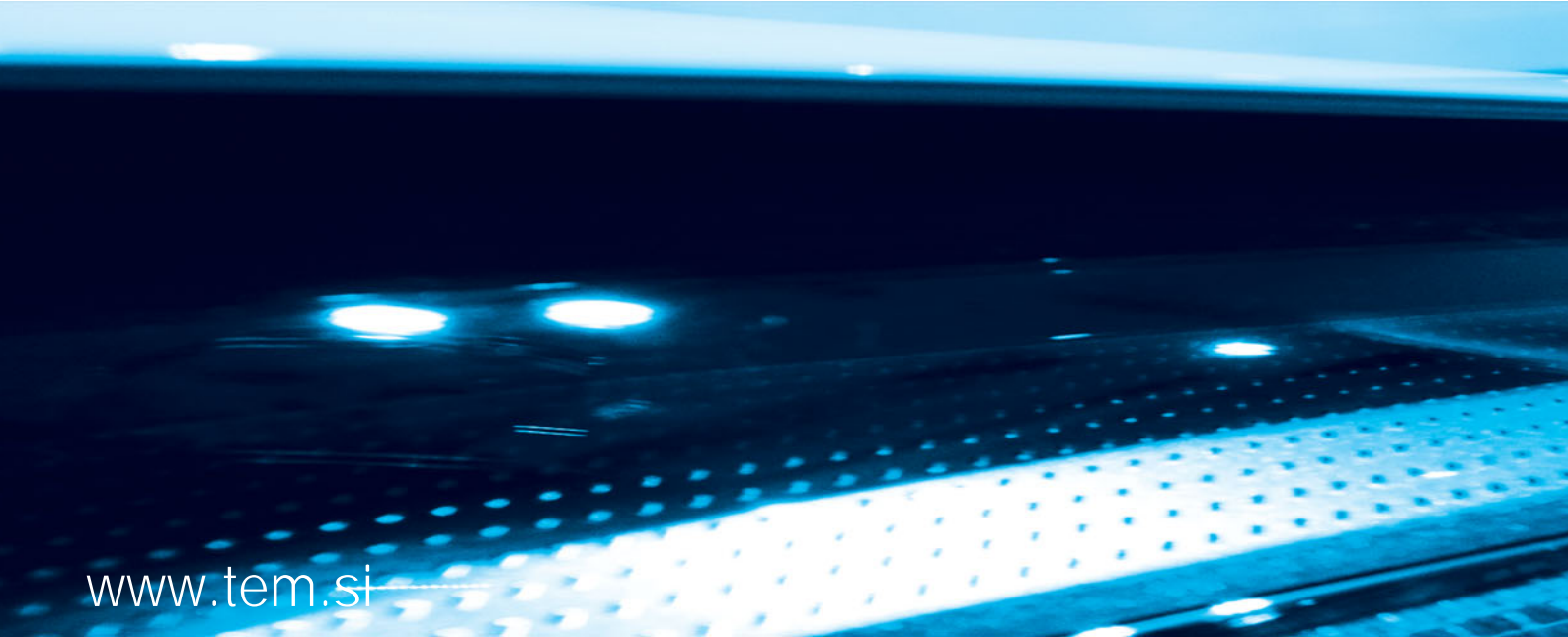

www.tem.si

SLO
2016